

Work Station Equipment

An extraction system is sized for only those outlets which are to be used simultaneously. This is in order to maximise efficiency and minimise the size of the central unit. All outlets must have some type of closure, either a valve or shutter. These can be manually actuated, such as flap valves or manual shutter valves, or automatically controlled for actuation only when extraction is required. Swing arms, hose reels and other suspension arrangements help further to increase the flexibility and efficiency of the system.

About Work Station Equipment

An extraction system is sized for only those outlets which are to be used simultaneously. This is in order to maximise efficiency and minimise the size of the central unit. It must be possible to open and close all outlets. This could be via manual shutter and flap valves or automatically on demand. The Flexpipe can be used for fume extraction, high flexibility and small diameter allow it to be placed very close to the fume source.

Overhead suspension arrangements such as swing-arms and hose reels can increase the usefulness of the system, increase ergonomics and minimise potential trip hazards from hose left on the floor.

When large volumes of material are to be introduced into the system, stainless floor funnels can be used from which the material is then extracted.

Manual Flap Valves

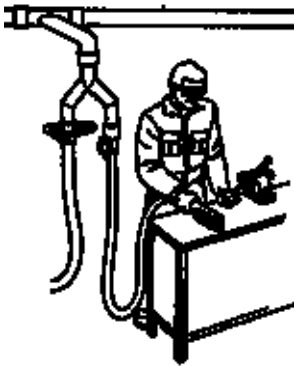

Automatic Flap Valves



Fume Arms and Suspension Arrangements

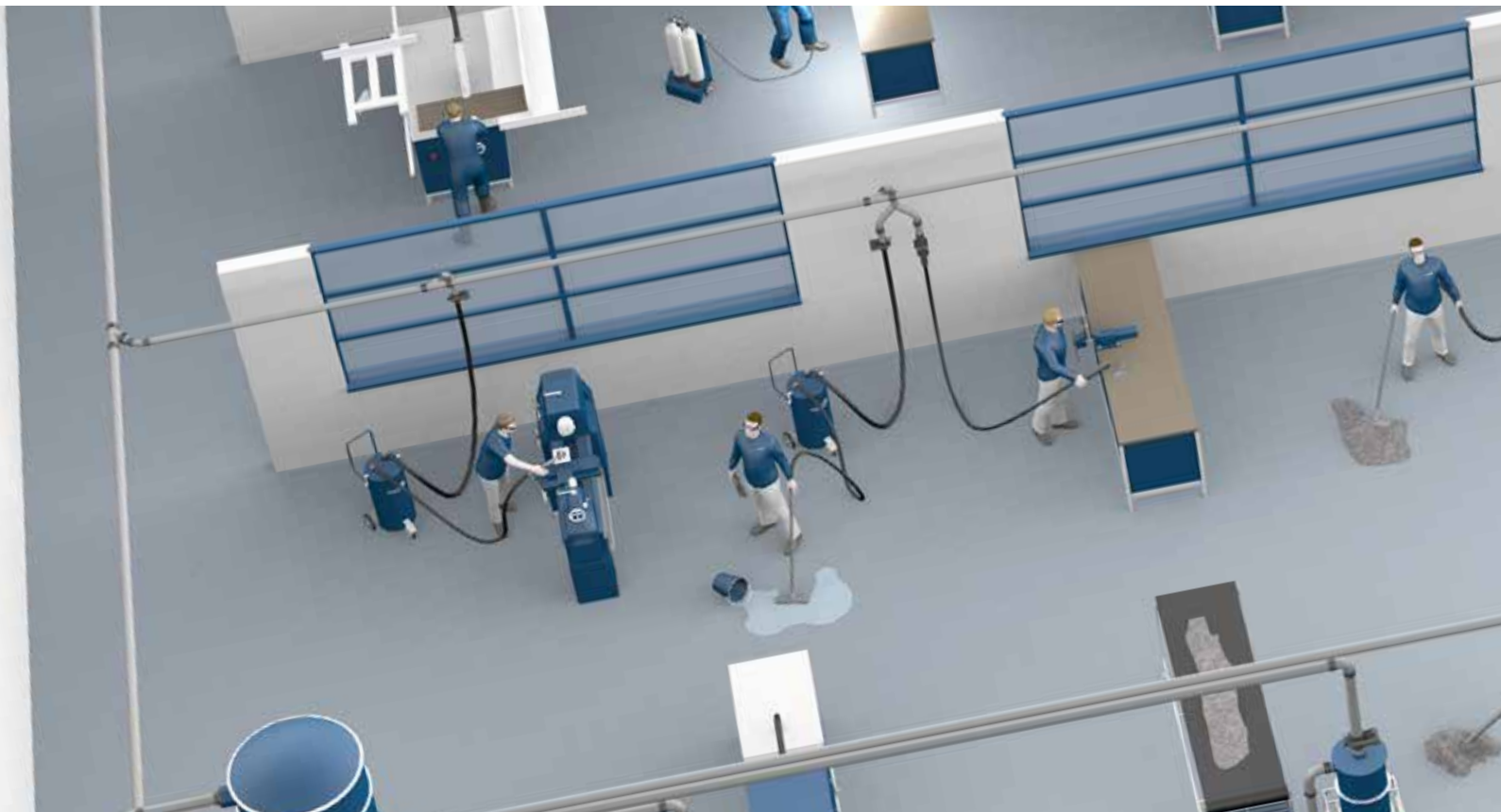
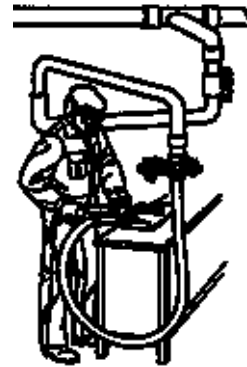

Work Station Equipment

Cutter 108

The Cutter 108 has been developed for cutting soft plastic, paper and cardboard strips and similar materials. The unit is connected to a tubing system and will cut all material in the transport flow into 2–15 cm sized pieces. A rotor with three knives work against one stationary knife.

The knives should be serviced at least twice a year at normal operation 8 hours a day. Depending on amount and type of material, the knives should be sharpened and adjusted every 500–5000 operation hours.

The tubing system before and after the Cutter should consist of straight pipes. Because of safety reasons the inlet and outlet pipes should each be at least one metre long. At installation and service the safety considerations should always be followed.

Part No	Description
7357	Cutter 108
40677	Exchange rotor Cutter 108

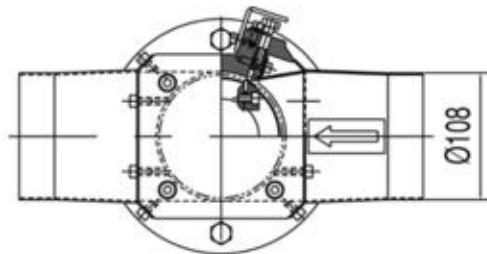
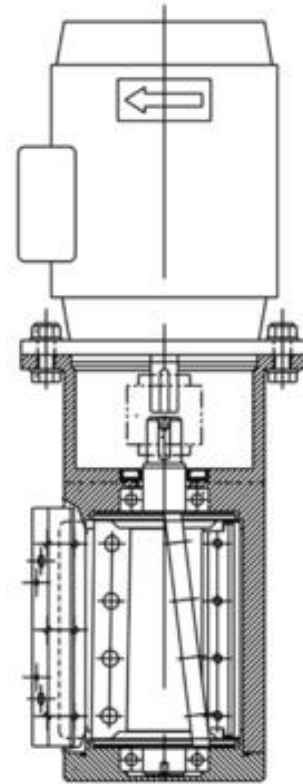

Technical data

	Cutter 108 50 Hz	Cutter 108 60 Hz
Weight	19 kg	19 kg
Inlet/outlet	Ø 108	Ø 108
Motor power	0.75 kW	0.75 kW
Rotation speed	2800 rpm	3400 rpm
Voltage	220-240 / 360-415	254-277 / 440-480

Work Station Equipment

Flap Valves

For ad hoc connection of the suction hose to the tubing system. The spring loaded flap is opened manually and the hose cuff is inserted into the valve body. On systems with on demand start-stop, the flap valve should be equipped with a micro-switch. This will give a start-stop signal for vacuum producer control.



Flap valve 50/76 with micro-switch

Installation Examples

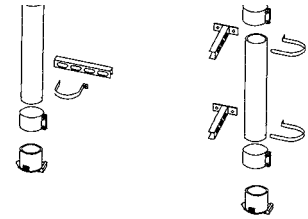

Technical data

d_{max}/D	A	Micro-switch	Part No
38/50 mm	X38	No	3232
38/50 mm	X38	Yes	8454
50/50 mm	X50	No	3070
50/50 mm	X50	Yes	8433
50/76 mm	X50	No	3006
50/76 mm	X50	Yes	8272
76/76 mm	X76	No	3237

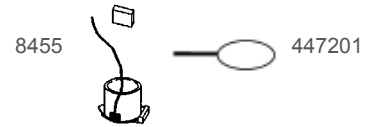

Flap Valves with micro-switch and attached lead

- 8455 Flap valve 50/76 (X50 connection) with micro-switch c/w 3 m lead and terminal box.
- 447201 Handle to open valve.



Work Station Equipment

Wall Outlets

For ad hoc connection of the suction hose. The suction hose must be equipped with a connecting sleeve. Installed in the wall with an installation kit, these provide a finished, flush mounted outlet valve. The valve body with spring loaded flap is installed after the wall is finished.

On systems with on demand start-stop, the wall outlet should be equipped with a micro-switch. This will give a start-stop signal for vacuum producer control.



Wall outlets are available with two finishes; peened aluminum or white enamel.

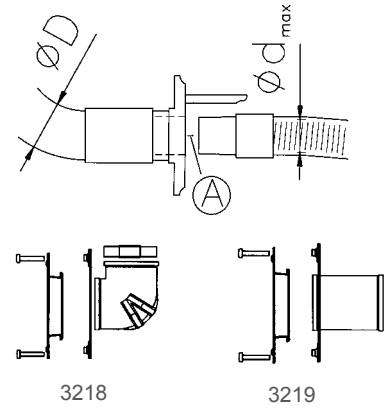

Technical data

d_{max}/D	A	Control	Finish	Part No
38/50 mm	X38	---	peened aluminum	3230
38/50 mm	X38	micro-switch	peened aluminum	8439
38/50 mm	X38	---	white enamel	3231
38/50 mm	X38	micro-switch	white enamel	8453



Accessories (Part No)

- 3218** Installation with 90° joint
- 3219** Installation set with straight joint

Wall Outlets

Dimensions, installation of wall outlets

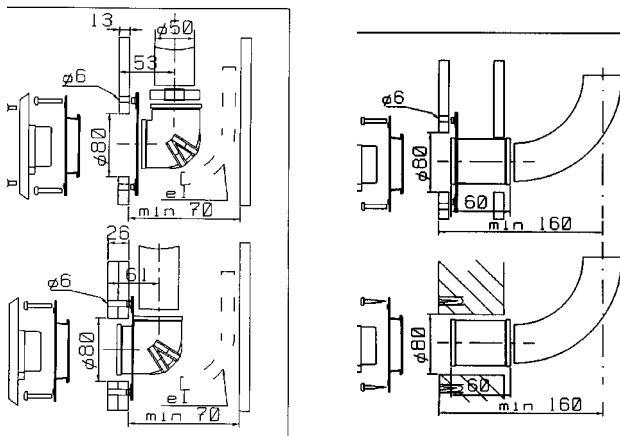

Work Station Equipment

Wall and Floor Outlet, Clean Room

The wall and floor outlet is designed to meet the requirement for clean room applications. The valve body is antistatic and made of pre-stressed polypropylene. The exposed surfaces of the valve are brushed stainless steel.

- The outlet is made for both wall and floor mounting.
- Cover wall mounting plate and spring replacement are possible without removing and replacing the valve body.
- Low profile for mounting even in thin wall partitions.
- Outlet optionally equipped with inductive sensor for auto start-stop.
- Select cleaning accessories Ø 32, 38 or 50 mm.



+ Accessories

Description	Part No. X38/50	Part No. X50/76
Wall mounting plate high	42783	432165
Straight joint	2044	3007
Rubber bend 90°	2043, Ø 50	2180, Ø 76/50
Anchor plate	42264	42950
Cover opener	40201	40201
Connector 62"	42292	-
O-ring 49.5 * 3 shore 50 nitril	40451	-

Part No	Description
322501	Clean room valve without sensor X38/50
84059	Clean room valve with sensor X38/50
3368	Clean room valve without sensor X50/76
3369	Clean room valve with sensor X50/76
40451	O-ring 49,56 * 3 shore 50
42292	Connector Clean room valve 38

Wall mounting

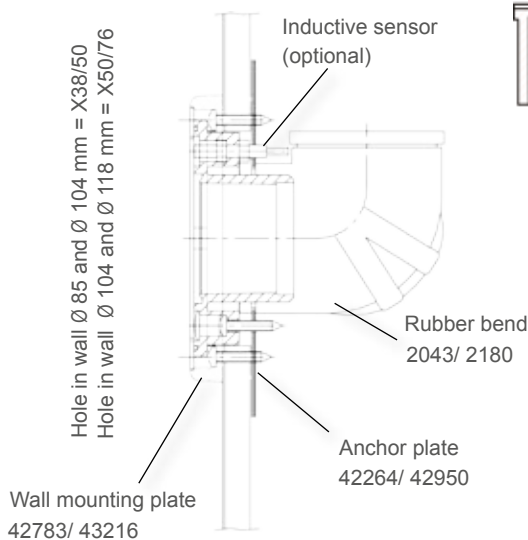

For wooden and raised floors

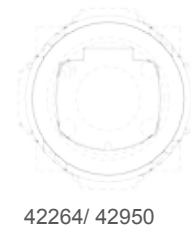
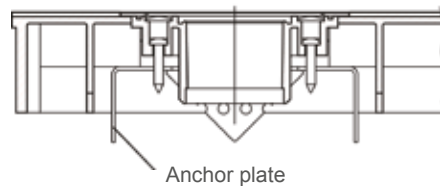

Anchor plate



For poured concrete floor

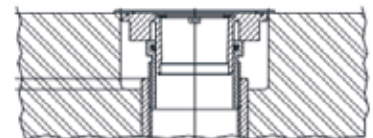
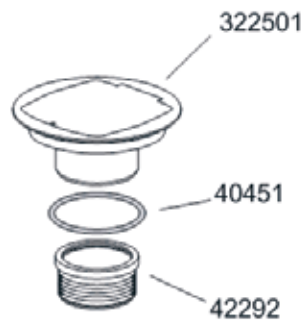

Work Station Equipment

Manual Shutter Valves

Manual shutter valves are used for stationary machine connection or in cases where a permanent hose connection is desired. By pulling the handle the valve opens.

On systems with on demand start-stop, the shutter valve should be equipped with a micro-switch. This will give a start-stop signal for vacuum producer control.



Technical data

D	Control	Part No
Ø 50 mm	---	805201
Ø 50 mm	micro-switch	809101
Ø 76 mm	---	804300
Ø 76 mm	micro-switch	809200
Ø 108 mm	---	808300
Ø 160 mm	---	8254
Ø 200 mm*/	---	8017
Ø 250 mm*/	---	8016

* / Note! Shutter Valve Ø 200 and Ø 250 only for clean air.

Automatic Shutter Valves

The shutter valve has a stainless steel gate actuated by a pneumatic cylinder. For applications on work stations and in the tubing system.

With intermittent start-stop, a pressure switch is installed using a "T" fitting in the compressed air supply. This provides an electrical start-stop signal to the vacuum producer. For valve position sensing, cylinder switches are optionally available. When a shutter needs to be electrically controlled, use an automatic shutter valve, as above, in combination with a solenoid valve as shown here.



Technical data

D	Part No
Ø 50 mm	805308
Ø 76 mm	804408
Ø 108 mm	808404
Ø 108 mm	808408 **/
Ø 160 mm	825404
Ø 200 mm*/	807500
Ø 250 mm*/	807800

Solenoid Valve Part No	V
8026	24 V DC
8088	24 V AC
8054	230 V

* / Note! Shutter Valve Ø 200 and Ø 250 only for clean air and to single step fans (10 kPa max).
 **/ For demanding environments.

Electric Shutter Valves

Electrically driven shutter valves can be built for special applications. Note that the speed of the gate will be much slower for an electrical shutter than for a standard shutter.



Technical data

Description	V	Part No
76 EL	230	804411
108 EL	230	808407
160 EL	230	825407

Work Station Equipment

Accessories Shutter Valve Auto and Electric

Accessories Shutter Valve Auto and Electric (Part No)

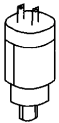

8047 Pressure Switch
Installed on pneumatic cylinders to supply electrical signals for start-stop control of vacuum producer. Gives signal when valve is opened.

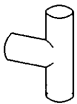

8152 T Fitting
Required for installation of the 8047 Pressure Switch.

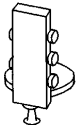

8040 Manual Switch
For manual actuation of auto shutters.

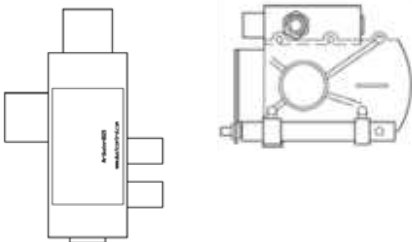

8020 Flow Valve
Actuates an auto shutter when installed in compressed air supply to a pneumatic tool. Controls on demand extraction. 8020 should be supported by compressed air according to PNEUROP 6611 CLASS 3. CA supply must be clean and dry, 90 PSI recommended.



8026 Solenoid 24 V DC
8054 Solenoid 230 V AC
8088 Solenoid 24 V AC
A separate solenoid is used for example, on stationary machines and in connection with a manual switch. The solenoid is connected pneumatically to the auto shutter. Generally installed in control panel of the subject machine.

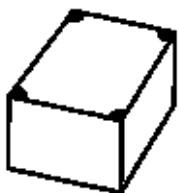

8196 Auto-start 230 V AC
Auto-start control is used for on demand extraction for electric tools (max 8 amps on subject tool). The auto-start current sensor closes a relay to give solenoid actuation of an auto shutter.



Work Station Equipment

+ Accessories Shutter Valve Auto and Electric (Part No)

8168 Welding Auto-start with current sensor Used for automatic control of extraction in induction welding applications. Striking an arc will cause the current sensor to close a relay. In turn the relay causes solenoid actuation of an auto shutter. This control must be supplied with 24 V AC, 0,5 A.

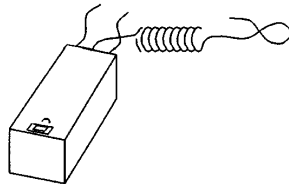

8029 Transformer 230/24 V AC 4 A Supply transformer for 8168 Welding Auto-start.

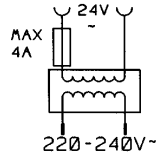

Vacuum Relief Valve

The vacuum relief valve bleeds in air at the pre-set relief level and can be installed at the outermost point on a tubing system. The valve will introduce transport air into the system when the pressure in the system exceeds the setting (12-29 kPa) of the vacuum relief valve.

Part No	Description
8253	Vacuum Relief Valve ø50
8001	Vacuum Relief Valve ø76
8002	Vacuum Relief Valve ø108

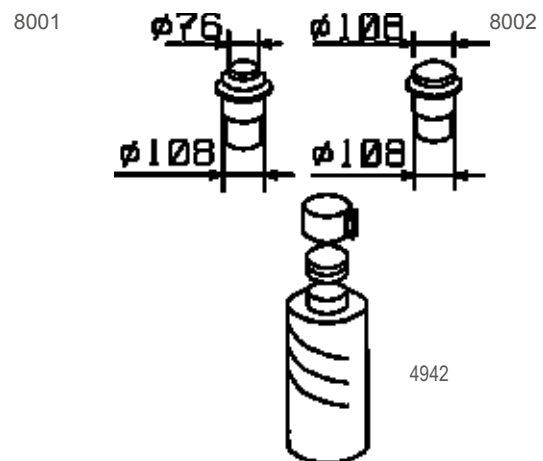

- + Accessories (Part No)**
- 4942** Silencer Ø 100 300/200
 - 42005** Tool Cage for vacuum valve

Work Station Equipment

Fume Extraction Arm

Extraction arm for welding fume etc. This articulated arm is easily adjusted to the correct working position. The hood is equipped with a 24 V 50 W halogen work lamp and dual switches for lamp and Electric Shutter Valve control. The 76 mm Extraction arm should always be installed with 1 m of 76 mm hose between the arm and tubing system.

Part No 590102 Ø 76

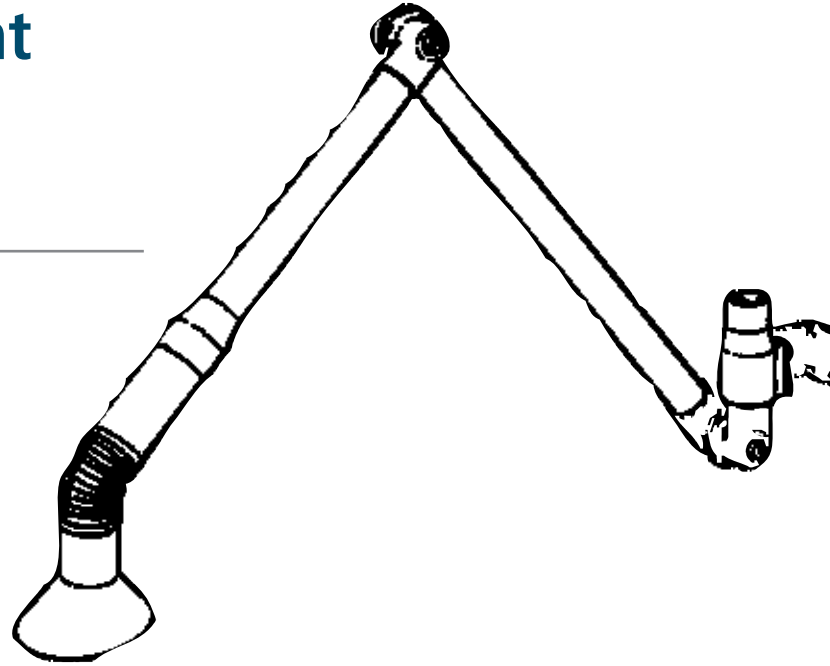

Accessories (Part No)

804411 Shutter Valve 76 Electric 230 V



Technical data

Description	Q_{nom}	Δp_{nom}
Ø 76	400 m ³ /h	3 kPa

In high pressure systems, the extraction arms may require a restrictive plate to compensate pressure for suitable air flow.



Work Station Equipment

Flexpipe

Dustcontrol's Flexpipe is a type of extraction arm for source extraction of welding fume, chemical vapors, wood, dust, etc. The flexpipe is a flexible hose that can be placed in practically any orientation desired.

The diameter of the Flexpipe is small and it can be used very close to the source without disturbing work. The extraction is very effective.

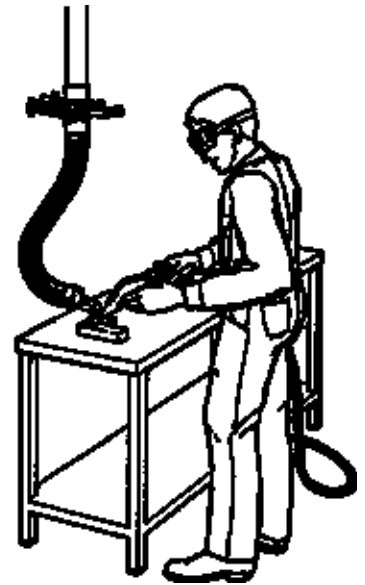

Mounting alternatives

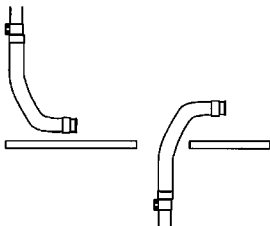

Technical data

Part No	7330	7308	7331	7332
Inner Diameter	Ø 50	Ø 50	Ø 76	Ø 76
Tubing System				
Connection	joint Ø 50	joint Ø 50	joint Ø 76	joint Ø 76
Length	700 mm	1 m	700 mm	1 m
Air Flow	80–200 m ³ /h	80–200 m ³ /h	200–450 m ³ /h	200–450 m ³ /h

Swingarm for Flexpipe

The Flexpipe reach can be increased with a swingarm installation. The swingarm length is easily adjusted by either cutting the horizontal tube or by replacing it with a longer tube from the standard tubing system, max. 3 m for Ø 50 and max. 4 m for Ø 76. The swingarm may be equipped with suction hose but should not be loaded with anymore than the weight of the hose itself.

Dimensions

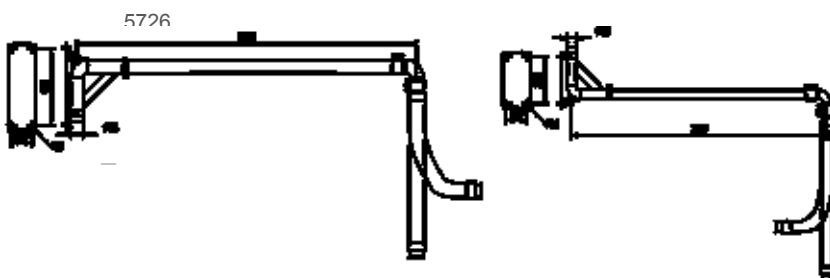

Part No	Description
5725	Ø 50
5726	Ø 76

Work Station Equipment

Swingarms

Swingarms are used to increase the working envelope without increasing hose lengths. Optionally, tools can be suspended from the swingarm.

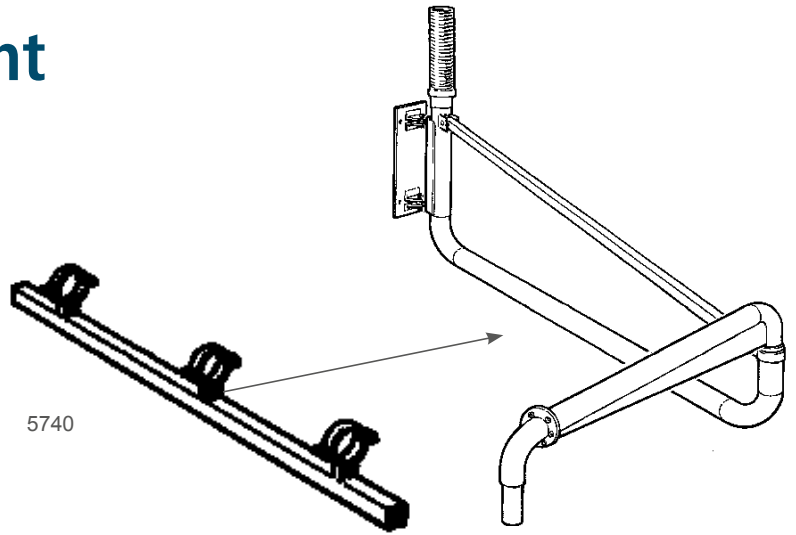

Part No	Description
5720	2.5 m
5721	3.5 m
5722	4.5 m
5723	6 m
5724	8 m

Dimensions

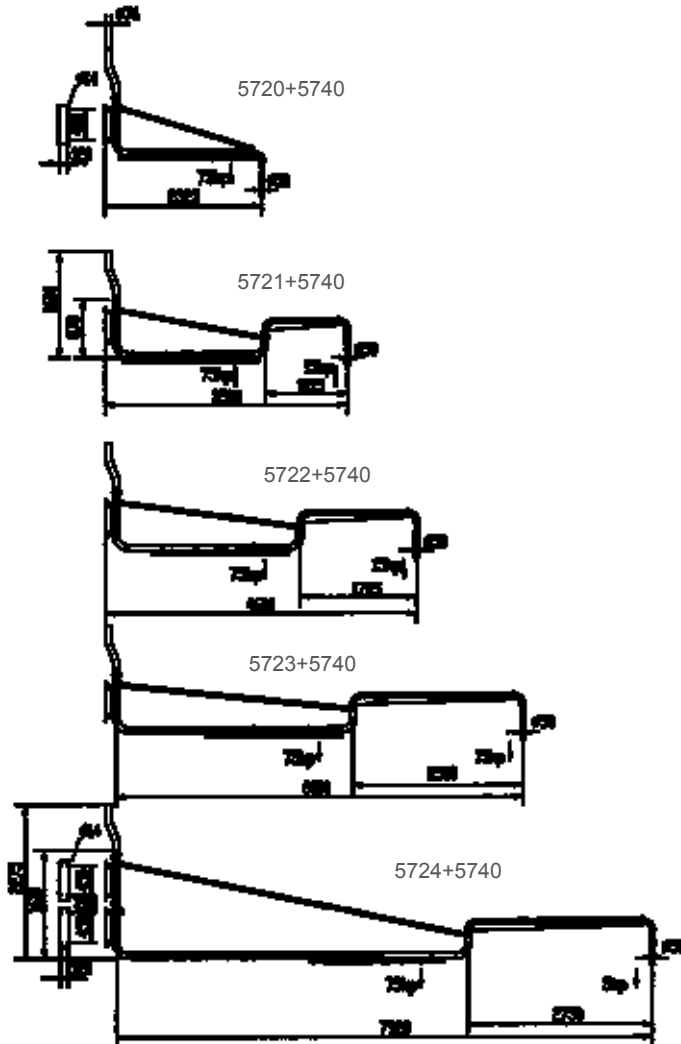

Accessories (Part No)

5740 Linear Suspension Track
The suspension track is installed on the inner link of the swingarm.

Mounting alternatives

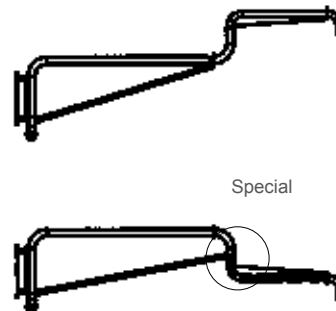

Work Station Equipment

Hose Reels

The DC Hose Reel 38/50 is the second generation of our spring operated hose reels and is a complete redesign. Due to its smooth operation the DC Hose Reel 38/50 is very user friendly. Simply pull down the hose and it locks in the desired position. Pull it again and the hose rewinds to the starting position.

The sealed drum guarantees smooth operation and protects the hose from every day wear and tear. The DC Hose Reel 38/50 can be installed either on the ceiling (part no 7503, 7506) or on the wall (part no 7504, 7505).

The DC Hose Reel 38/50 is more sturdy, has a long reach and a wide radius of action due to the extended hose. The sealed drum is not pivotal and mounted in a fixed position instead.



7505 Hose Reel

Part No Description

7503	Hose Reel 38 mm, complete, ceiling
7504	Hose Reel 38 mm, complete, wall
7505	Hose Reel 50 mm, complete, wall
7506	Hose Reel 50 mm, complete, ceiling

7504/7505 Wall

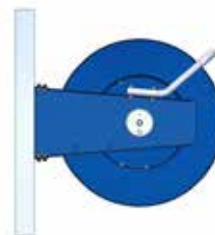

Hose guide installed outwards.

7503/7506 Ceiling



Hose guide installed upwards.



Accessories (Part No)

4942	Silencer Ø 100 300/200
42005	Tool Cage for vaccumvalve
7507	Wall Bracket Hose Reel, turnable



Technical data

Dimension	38 mm	50 mm
Hose part no /length, antistatic	2013/8 m/26 ft., Ø 50 mm/2 in. + 2012/2 m/6 ft., Ø 38mm/1.5 in.	2013/10 m Ø 50 mm/2 in.
Connection diameter	Ø 50 mm/2 in.	Ø 50 mm/2 in.
Compressed air supply	min 5 bar (75 psi)	min 5 bar (75 psi)
Recommended air flow	100-150 m³/h	150-320 m³/h

For specific information about the hoses – see Material properties hoses.

Work Station Equipment

Tool Holder with Flow Control

Dustcontrol's tool holder with flow control has been developed for hand-held tools that are connected to a source extraction system. The suction flow shuts automatically when the user puts the tool into the holder and opens when it is removed. This function reduces the energy consumption while making the working process more efficient. In its standard configuration, the tool holder can be used for brush nozzles and grinding tools with discs with a diameter up to 180 mm.



Technical data

Dimensions (HxWxL) 210 x 210 x 210 mm/8,3 x 8,3x 8,3 in.

Weight 3 kg / 7 lb

Connection Ø Pneumatic tubing 6 mm / 1/4 in.

A



A Holder for hand-held tools

B

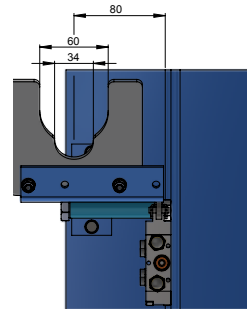

B Spring-loaded 5/2-valve (controls the shutter valve within the extraction system)

Part No 432193 Tool Holder

FilterSaver

The FilterSaver distributes the jet pulse evenly over the whole filter area, facilitating better removal of dust stuck to the filter. By removing more dust the pressure drop over the filter is reduced. A reduced pressure drop also increases the service life of the filter, reduces the energy consumption and increases the suction of the system.

Part No	Description
43925	FilterSaver for filter part no 4284
43926	FilterSaver for filter for part no 4292



Filter cleaning with FilterSaver