



NITROSOURCE PLUS

PSA NITROGEN GAS GENERATORS

Engineered to provide unparalleled efficiency and reliability, ensuring consistent and cost effective on-site nitrogen production.

INDUSTRY LEADING TECHNOLOGY

Increased profitability for producers in a wide range of markets

Efficient and Reliable On-site Nitrogen Gas Generation

The **NITROSource Plus** nitrogen gas generator range is designed to revolutionize users operations with its state of the art Pressure Swing Adsorption (PSA) technology. This advanced system offers an on-site, reliable, high purity nitrogen gas solution that is efficient and cost effective.



PSA technology utilising Carbon Molecular Sieve - designed for over 10 year's operational life.

Parker's **NITROSource Plus** is engineered to meet the stringent demands of a variety of industries including food and beverage, pharmaceuticals, electronics manufacturing, chemical processing and laser cutting. By generating nitrogen gas directly from compressed ambient air, it eliminates the need for traditional, costly, and logistically complex methods of nitrogen supply such as high pressure gas cylinders or bulk liquid deliveries.

With **NITROSource Plus** nitrogen gas generators, users benefit from unparalleled performance and versatility. The system is designed to deliver consistent nitrogen purities ranging from 3% to 5ppm catering for the specific requirements of users processes. This not only ensures product quality and safety but also enhances operational efficiency and reduces downtime.

In addition to its superior performance, the **NITROSource Plus** range offers significant cost savings and environmental benefits. By producing nitrogen gas on demand, **NITROSource Plus** minimizes waste and reduces the carbon footprint associated with transportation and handling of compressed gas. The robust design ensures long-term reliability and minimal maintenance, providing seamless integration into your existing operations.

Multi-banking

NITROSource Plus can be multi-banked to provide extra capacity. Should demand increase in the future, there is no need to replace the nitrogen generator with a larger unit, instead additional generators

can be added to the system to meet increased demand. Multi-banking allows individual generators to be easily isolated for routine service work whilst maintaining uninterrupted gas output.

Compliance

The **NITROSource Plus** range has been independently tested by a third party accredited authority to demonstrate compliance with global standards for food, beverage and pharmaceutical grade nitrogen gas.

Warranty

As standard all **NITROSource Plus** nitrogen gas generators are covered under a 1 year manufacturer's warranty although this can be upgraded to a 1+4 or 1+9 year extended warranty*.



*Subject to Parker's extended warranty terms and conditions.

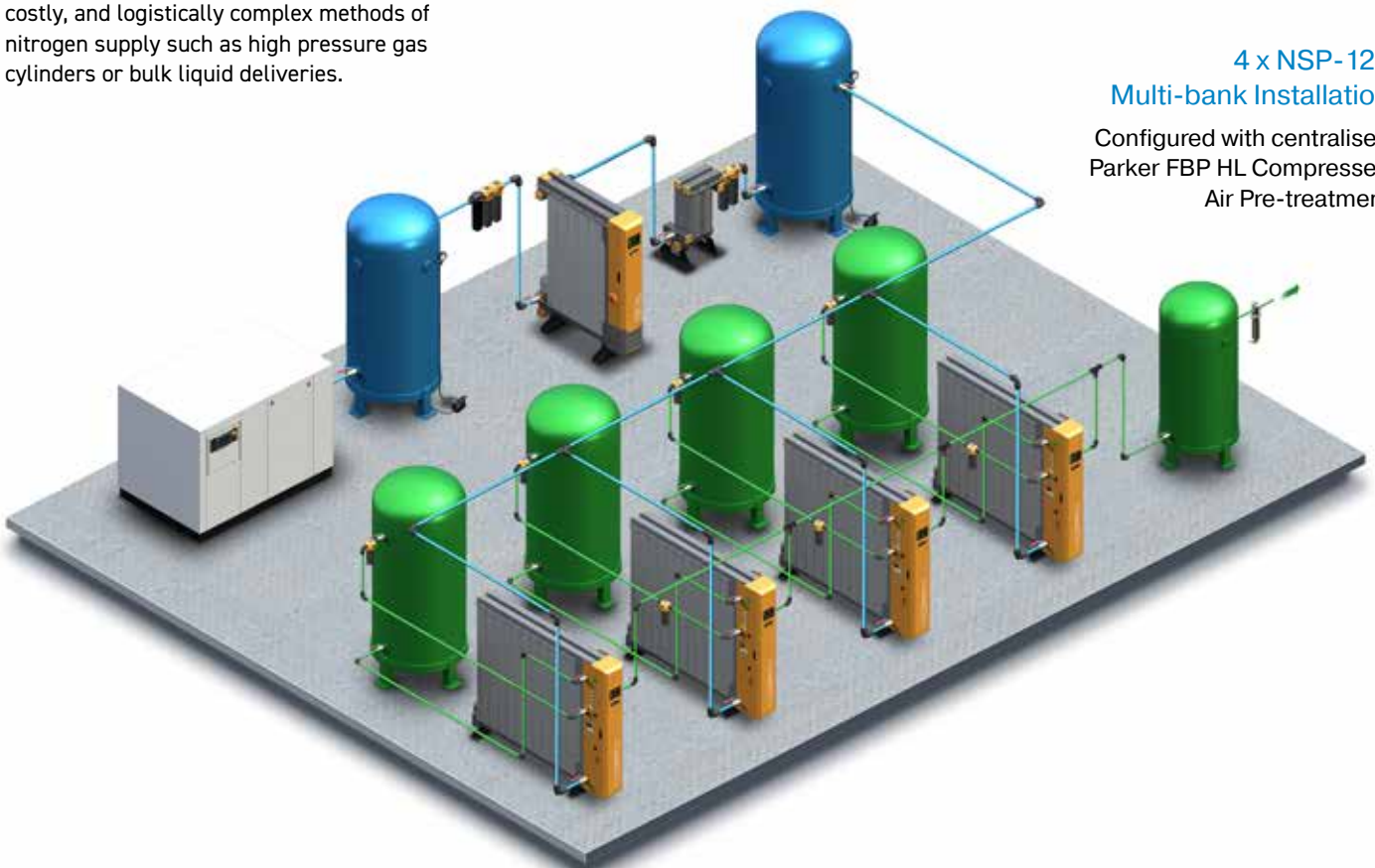

4 x NSP-120 Multi-bank Installation

Configured with centralised
Parker FBP HL Compressed
Air Pre-treatment

KEY FEATURES & BENEFITS

A configuration for every application

Designed to meet the requirements of every application or process, Parker's NITROSource Plus nitrogen gas generator range offers greater flexibility than ever before.

Integral Zirconia Oxygen Analyser

A standard feature on all **NITROSource Plus** generators is the new integral Zirconia technology oxygen analyser, offering greater accuracy and faster response time with a vastly longer service life. For Pharmaceutical applications, an optional Electrochemical oxygen analyser is available to ensure compliance with European Pharmacopoeia.



Off Gas Bypass

If the nitrogen gas oxygen content is out of specification, safety features within the advanced controller detect this and vent the gas from the generator and buffer vessel to atmosphere preventing out of specification gas from contaminating the application or process whilst automatically purging the generator to restore gas purity.

Mass Flow Controller

The mass flow controller ensures that the output nitrogen flow and pressure remains stable regardless of downstream fluctuations, unlike other flow control devices such as needle or gate valves, that can cause fluctuating flow rates due to changes in downstream pressure. The mass flow controller is critical to the gas generation process ensuring protection of the CMS bed from over-flow conditions that could affect the gas purity.

Energy Saving Technology (EST)

Developed to constantly monitor the oxygen content of the CMS bed and adjust the generators cycle time based upon extra capacity at part load conditions.



All PSA nitrogen generators consume the most compressed air at the point of column changeover, this is where gas is exhausted and compressed air is used to re-pressurise. If the changeover period increases, then the accumulative effect is lower overall air consumption.

A generator operating on a fixed timing cycle typically uses the same amount of compressed air under part load conditions as it does at 100% load. Therefore, the air to nitrogen ratio becomes much higher becomes much higher. It is important to note that compressed air to nitrogen figures for fixed timing cycle nitrogen generators are only accurate when operating at 100% rated flow.

Outlet Pressure Regulation

Maintains a stable nitrogen outlet pressure protecting the application or process from fluctuations and over-pressure.

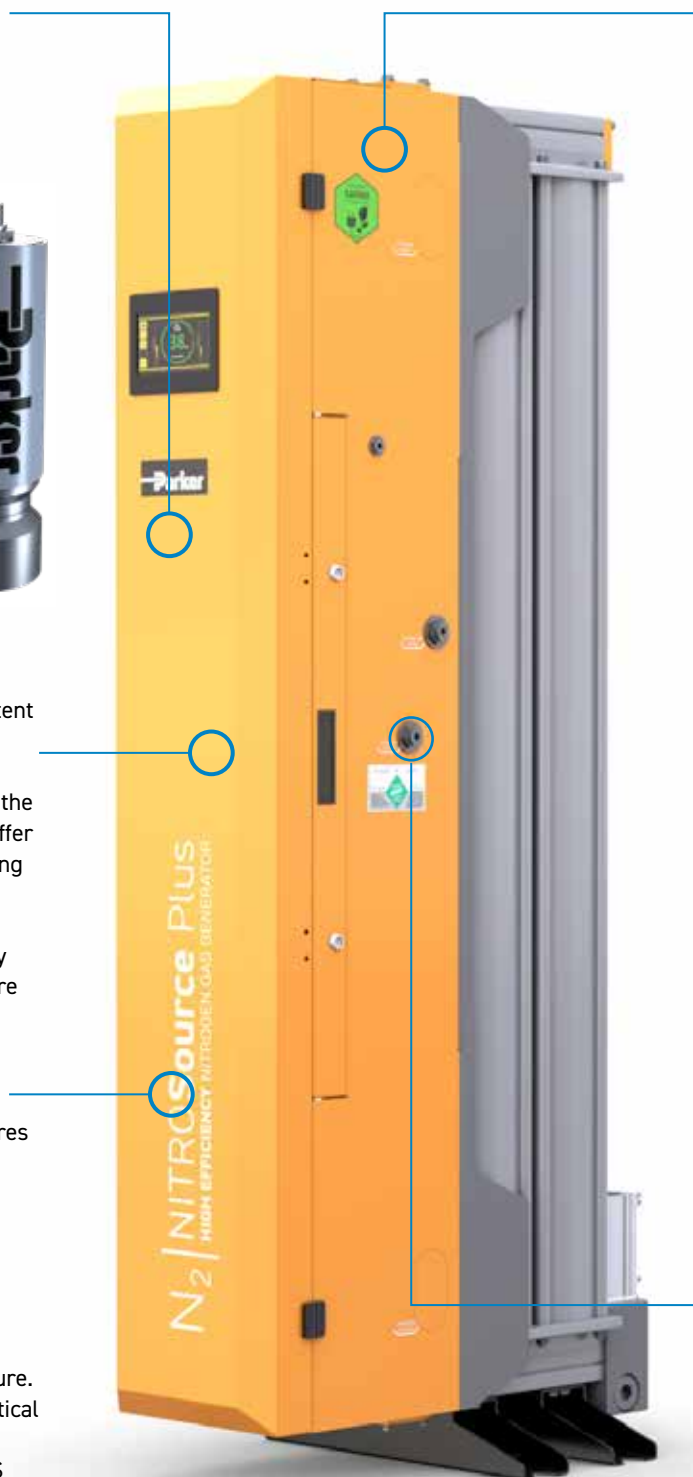

ADVANCED CONTROLLER

Intelligent Monitoring, Control & Connectivity

The NITROSource Plus advanced controller comprises of a multi-voltage, multi-frequency power supply feeding an expandable PLC controller and a 7" colour touchscreen display housed inside an IP32 rated enclosure. Paired with an intelligent and intuitive user interface that allows for quick and easy operation of the nitrogen generator.

Various sensors are installed on the gas generator which are essential to its operation. These sensors are continuously monitored by the advanced controller to ensure efficient operation of the gas generation process and uninterrupted supply of nitrogen gas.

As standard, the controller continuously monitors:

- Ambient Temperature
- Inlet Pressure
- Outlet Pressure
- Column Pressures
- Nitrogen Outlet O₂ Content

The controller has the capability to accept additional sensors which can be installed to further protect the generator from contamination or monitor different aspects of the gas generation process.

These optional sensors include:

- Inlet Dewpoint
- Inlet Flow Rate
- Outlet Dewpoint
- Outlet Flow rate
- EST O₂ Content

The advanced controller now offers data logging capability. The information acquired from each sensor is saved to the PLC's internal memory. This data can then be reviewed in graphical form through the 7" colour touchscreen or through the Web server remote access.

The controller offers multiple connection methods and communication protocols with the option to offer alternative protocols via additional gateways.



Purity Display



Sensor Display

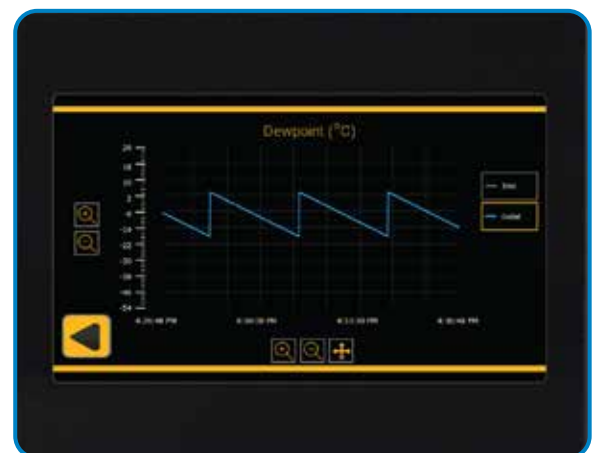

Dewpoint Trends

Controller Connectivity

Feature	Standard	Optional
Web server (via Ethernet RJ45)	•	
Modbus TCP/IP (via Ethernet RJ45)	•	
Outlet O ₂ Content 4...20mA Output	•	
EST O ₂ Content 4...20mA Output		•
Warning Alarm Relay	•	
Fault Alarm Relay	•	

FEATURES AND OPTIONS

Multiple Connectivity and Monitoring Options Available

A key feature of the advanced controller is its commonality of user interface with Parker's compressed air pre-treatment products. The interface is easy to navigate, and offers a wide variety of features and variables that can be interrogated or monitored.

The table below indicates features and data that can be accessed or controlled through the various communication methods.

Available via Touchscreen	Available via Remote Communication				
	Web server Remote Access	Modbus TCP/IP	4...20mA Retransmission	Warning Alarm Relay	Fault Alarm Relay
Start / Stop Function		•			
Column Status	•	•			
Economy Stage 1 Status	•	•			
Economy Stage 2 Status	•	•			
EST Status*	•	•			
Machine Status	•	•			
Timing Cycles	•				
Alarm Status	•	•		•	•
Alarm Logs	•	•			
Service Status	•	•			
Service Logs	•				
Operational Hours	•	•			
Operational Counters	•	•			
Ambient Temperature	•	•		•	
Inlet Pressure	•	•		•	
Inlet Dewpoint*	•	•		•	•
Inlet Flow Rate*	•	•			
Column 1 Pressure	•	•			
Column 2 Pressure	•	•			
Outlet Pressure	•	•			
Outlet Dewpoint*	•	•			
Outlet Flow Rate*	•	•			
Outlet O2 Content	•	•	•	•	•
EST O2 Content*	•	•	•		
Data Trends	•				
HMI Configuration Settings	•				
HMI Language Selection	•				
Product Details (Serial No. etc)	•	•			

*Only available if option is fitted

SIZING AND SELECTION

Nitrogen Outlet Flow Rates

Model	Purity (Remaining Oxygen Content) vs Nitrogen Outlet Flow (m ³ /hr)*										
	5ppm	10ppm	50ppm	100ppm	250ppm	500ppm	0.1%	0.5%	1.0%	2.0%	3.0%
NSP-020	7.0	8.0	10.1	11.4	13.4	15.1	17.0	23.2	27.3	32.8	37.5
NSP-030	9.4	10.8	14.6	16.6	19.7	23.1	25.8	34.7	40.9	48.7	55.1
NSP-040	12.5	14.4	19.4	22.1	26.2	30.8	34.4	46.3	54.6	64.9	73.4
NSP-050	15.6	18.0	24.3	27.7	32.8	38.5	43.0	57.9	68.2	81.1	91.8
NSP-060	18.8	21.5	28.6	32.5	38.9	44.3	50.0	68.1	80.2	95.4	110.1
NSP-070	21.9	25.1	33.3	38.0	45.4	51.7	58.3	79.4	93.6	111.3	128.5
NSP-080	25.0	28.7	38.1	43.4	51.9	59.1	66.7	90.8	106.9	127.2	146.8
NSP-090	28.1	32.3	42.8	48.8	58.4	66.4	75.0	102.1	120.3	143.1	165.2
NSP-100	34.3	39.1	52.0	56.8	66.1	74.1	83.8	114.8	134.7	164.5	178.7
NSP-110	37.7	43.0	57.2	62.5	72.7	81.5	92.2	126.3	148.2	180.9	196.2
NSP-120	41.2	46.9	62.4	68.2	79.3	88.9	100.6	137.8	161.6	197.3	-

Performance data is based on 7.0 bar(g) (101.5 psi(g)) inlet and 20°C (68°F) ambient temperature.

*m³ reference to standard conditions, 20°C, 1013 mbar(a) and 0% relative water vapour pressure.

Part Number Breakdown / Product Key

Product Code		Model		Purity	Oxygen Analyser Technology	Energy Saving Technology ⁽¹⁾	Nitrogen Outlet Flow Range ⁽²⁾	Dew point Monitoring				
NSP	-	020	-	U	E	N	H	N	-	0	0	A
		030		H	Z	Y	L	I				
		040		L				O				
		050						B				
		060										
		070										
		080										
		090										
		100										
		110										
		120										

NSP = NITROSource Plus

U = 5ppm / 10ppm / 50ppm

H = 100ppm / 250ppm / 500ppm / 0.1%

L = 0.5% / 1.0% / 2.0% / 3.0%

E = Electrochemical

Z = Zirconia

N = Not Fitted

Y = Fitted

H = High

L = Low

N = Not Fitted

I = Inlet PDP Monitoring

O = Outlet PDP Monitoring

B = Both Inlet & Outlet Monitoring

⁽¹⁾ Energy Saving Technology not available on 50ppm, 10ppm or 5ppm generators.

⁽²⁾ See 'Mass Flow Controller Flow Breaks' chart for sizing information.

Mass Flow Controller Flow Breaks

Outlet Pressure	bar(g)	5	6	7	8	9	10	11	12	13
		psi(g)	72.5	87	101.5	116	130.5	145	159.5	174
High Flow	m ³ /hr*	190.0	205.0	219.0	232.0	245.0	257.0	268.0	279.0	290.0
Low Flow		61.0	66.0	70.0	74.0	78.0	82.0	86.0	89.0	93.0

*m³ reference to standard conditions, 20°C, 1013 mbar(a) and 0% relative water vapour pressure.

TECHNICAL SPECIFICATIONS

Operation Parameters

Minimum Inlet Air Quality	ISO 8573-1: 2010 Class 2.4.1	
Minimum Operating Pressure	5.0 bar(g)	72.5 psi(g)
Maximum Operating Pressure	13.0 bar(g)	188.5 psi(g)
Design Pressure	15.0 bar(g)	217.5 psi(g)
Minimum Operating Temperature	5.0°C	41.0°F
Maximum Operating Temperature	50.0°C	122.0°F
Recommended Operating Temperature	20.0°C	68.0°F
Supply Voltage	100-240V AC (±10%) 50/60Hz	
Power Consumption	100W	
IP Rating	IP32	NEMA 2
Noise	<75 dB (A)	

Pipe Connections & Buffer Vessel Sizes

Model	Pipe Connections				Buffer Vessel	
	Compressed Air Inlet	Nitrogen Outlet	To Buffer	From Buffer	Minimum* Capacity	
NSP-020	1" BSPP	1" BSPP	1" BSPP	1" BSPP	270 Litres	71 Gallon
NSP-030	1" BSPP	1" BSPP	1" BSPP	1" BSPP	500 Litres	132 Gallon
NSP-040	1" BSPP	1" BSPP	1" BSPP	1" BSPP	500 Litres	132 Gallon
NSP-050	1" BSPP	1" BSPP	1" BSPP	1" BSPP	1000 Litres	264 Gallon
NSP-060	1" BSPP	1" BSPP	1" BSPP	1" BSPP	1000 Litres	264 Gallon
NSP-070	1" BSPP	1" BSPP	1" BSPP	1" BSPP	1000 Litres	264 Gallon
NSP-080	1" BSPP	1" BSPP	1" BSPP	1" BSPP	1500 Litres	396 Gallon
NSP-090	1" BSPP	1" BSPP	1" BSPP	1" BSPP	1500 Litres	396 Gallon
NSP-100	1½" BSPP	1" BSPP	1½" BSPP	1" BSPP	1500 Litres	396 Gallon
NSP-110	1½" BSPP	1" BSPP	1½" BSPP	1" BSPP	1500 Litres	396 Gallon
NSP-120	1½" BSPP	1" BSPP	1½" BSPP	1" BSPP	2000 Litres	528 Gallon

*Important Note:

Recommended minimum buffer vessel size to guarantee maximum outlet pressure.

Utilisation of smaller buffer vessels may result in lower outlet pressures and fluctuations in purity.

Weights & Dimensions

Model	Height (H)		Width (W)		Depth (D)		Weight	
	mm	ins	mm	ins	mm	ins	kg	lbs
NSP-020	2063	81.22	550	21.65	883	34.7	335	739
NSP-030	2063	81.22	550	21.65	1052	41.4	429	946
NSP-040	2063	81.22	550	21.65	1221	48.1	522	1151
NSP-050	2063	81.22	550	21.65	1390	54.7	615	1356
NSP-060	2063	81.22	550	21.65	1559	61.3	710	1565
NSP-070	2063	81.22	550	21.65	1728	68.0	805	1775
NSP-080	2063	81.22	550	21.65	1897	74.6	897	1978
NSP-090	2063	81.22	550	21.65	2028	79.8	988	2178
NSP-100	2063	81.22	550	21.65	2194	86.3	1104	2434
NSP-110	2063	81.22	550	21.65	2360	92.9	1197	2639
NSP-120	2063	81.22	550	21.65	2526	99.4	1292	2848

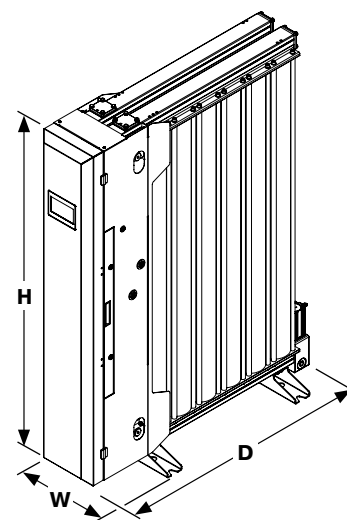



Service & underhåll

En viktig del i vårt koncept som totalleverantör och partner, är att kunna erbjuda kvalificerad specialtjänst för tillsyn, service och underhåll av kompressorer, tryckluftsanläggningar och gasgeneratorer. Genom att teckna serviceavtal med oss, kommer kvalificerad service, rätta reservdelar, effektiva rutiner och löpande dokumentation att garantera en säkrare drift och användning för att distribuera ren tryckluft och rätt kvävgaskvalitet.



ISO 14001

Granzow service är certifierad enligt ISO 14001 vilket medför att kvalitets- och miljötänkande är naturliga faktorer i vårt arbete. Vi ser som en av våra uppgifter att hålla våra kunders tryckluftproduktion igång och samtidigt utföra uppdraget med utgångspunkt från högt ställda kvalitets- och miljökrav.



Rätt kapacitet



Rätt kvalitet



Rätt tryck



Rätt service

GRANZOW

svensk tryckluftspartner

Service: 020-78 80 00
Försäljning: 0171-47 80 00
www.granzow.se