

# M VERSAPRO™ DICER

## NEXT GENERATION PROTEIN PROCESSING

Building on the Urschel Models M and M6, the M VersaPro™ (MVP) Dicer provides the best in sanitary design and the ultimate in versatile cutting of proteins. Available with optional HMI (shown). The MVP offers 33% increased feeding capacity versus the standard M6 due to wider belts, optimized cutting, and increased horsepower. The belt-fed MVP delivers 2-dimensional dices, strips, or shreds from product of a predetermined thickness. The dicer offers infeed and takeaway belts to prevent product build-up. Takeaway belt facilitates discharging into totes. Ideally suited for cutting frozen-tempered, fresh-chilled, or hot-cooked beef, pork, protein alternatives, or poultry. Maximum input product size for firm products should not exceed 1.5" (38.1 mm).



## TYPES OF CUTS

### DICE

Many sizes of cuts are possible by combining the various selections of circular knife spacings with different crosscut knife spindles.

**Circular range:** 3/16 to 1-1/2" (4.8 to 38.1 mm)

**Crosscut range:** 1/8 to 3" (3.2 to 76.2 mm) standard sizes, fully adjustable up to 6" (152 mm) with variable speed crosscut motor.

### STRIP CUT

Strip cut a variety of widths by removing either the crosscut knife spindle assembly or the circular knife spindle assembly. The final thickness of the strip will be the same thickness as the original product.

### SHRED

To produce shreds from meat products, the crosscut knife spindle is replaced by a shredding spindle. The length of the shred can be controlled by orientation of the meat fibers of the incoming product and by the use of a circular knife spindle. Many variables can affect the final product; consult an Urschel representative for details.

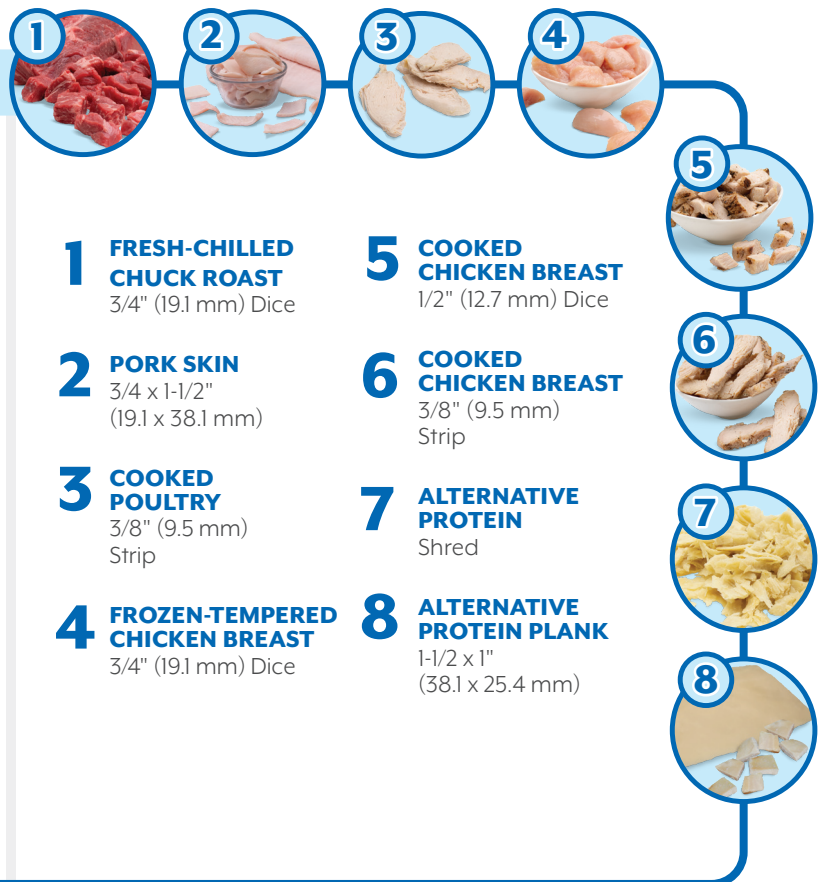

## CUTTING OVERVIEW

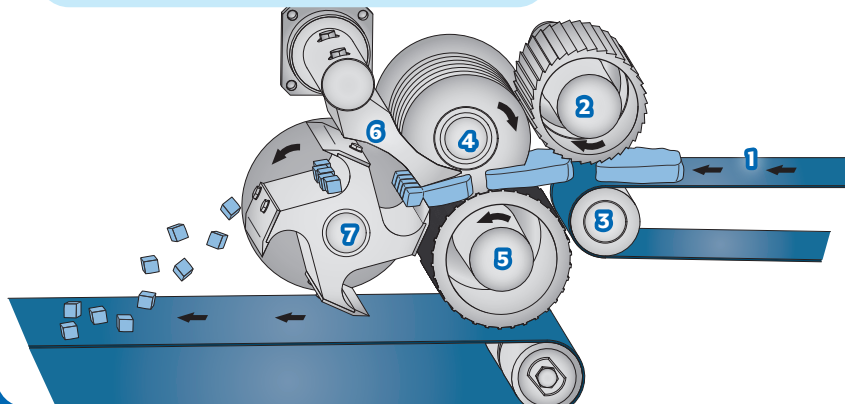

1. Feed Belt
2. Feed Roll
3. Drive Roll
4. Circular Knives
5. Feed Drum
6. Stripper Plate
7. Crosscut Knives  
(new †patented  
fluted design shown)

If your product application is not mentioned on this page, contact your local Urschel representative to determine the most effective solution to your size reduction needs.

# M VERSAPRO™ DICER

**Length:**.....129.36" (3286 mm)  
**Width:**.....33.90" (861 mm)  
**Height:**.....68.38" (1737 mm)  
**Net Weight:** .....2600 lb (1179 kg)  
**Motors:**.....5 or 7.5 HP (3.7 or 5.6 kW)  
 .....5 HP (3.7 kW) Crosscut

Measurements and weights may vary depending on machine configuration.



SPECIFICATIONS & DIMENSIONS

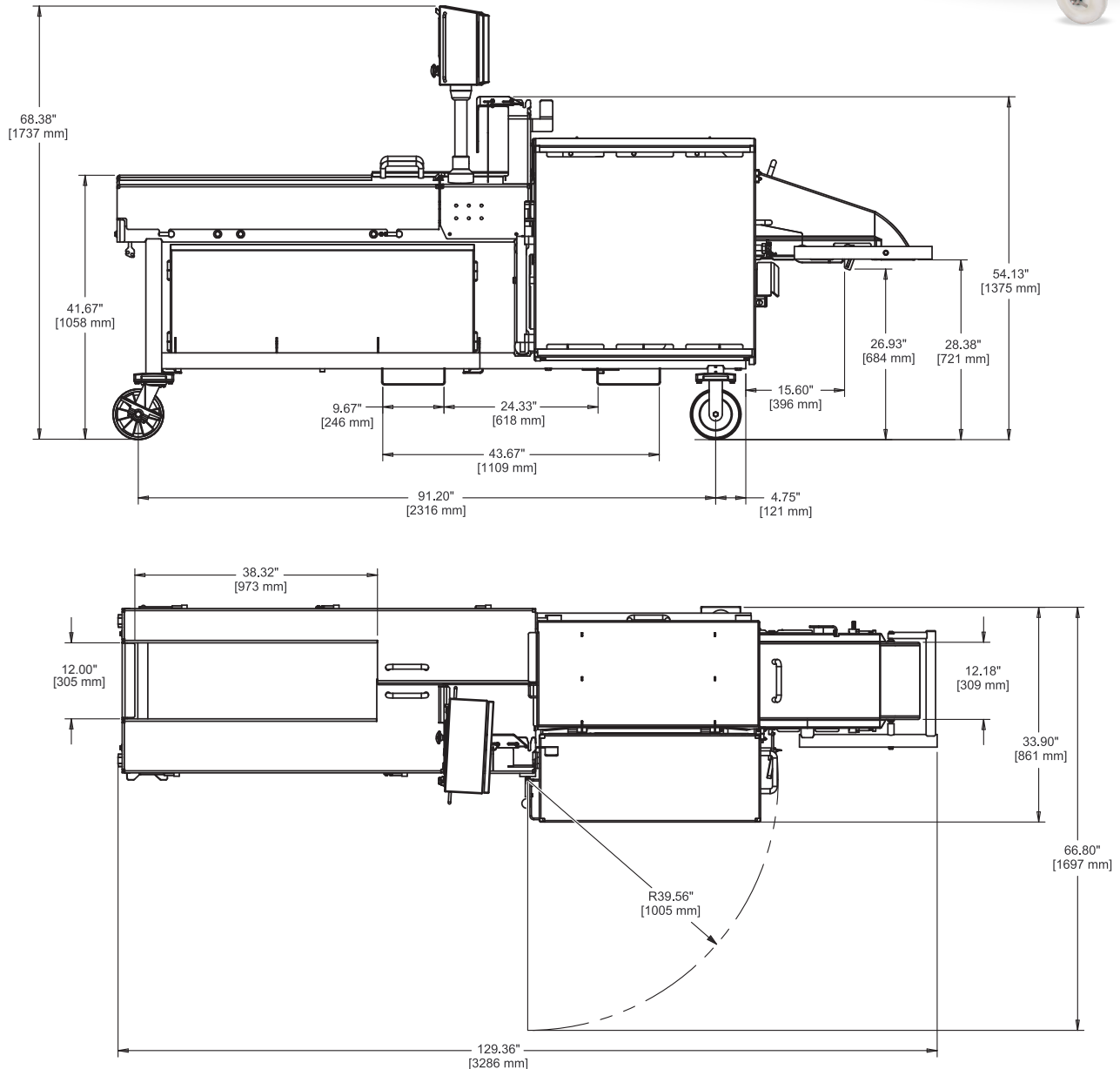

## TEST CUT YOUR PRODUCT

Test cutting of your product is available in-person, live remotely, or via video. Contact your local Urschel representative to schedule a comprehensive, no-obligation test today at [www.urschel.com](http://www.urschel.com).



**URSCHEL®**  
The Global Leader in Food Cutting Technology

[www.urschel.com](http://www.urschel.com) | ✉ [info@urschel.com](mailto:info@urschel.com)