

 Quality  
Made in  
Germany

Moulding

**MARTIN**



Turning rough  
raw materials into  
fine profiles!



ConnectControl  
Technology

In addition to their basic equipment, MARTIN spindle and tilting arbor spindle moulders have numerous useful and patented options that add value to your machine, and perfect your workpiece.

You can easily configure your MARTIN spindle moulder according to your individual needs online on our website

**[www.martin.info](http://www.martin.info)**



Specifications	6
T14	8
T29	10
ConnectControl	12
T14   T29 options	30
Dimensional sketches	52

# T14



This compact spindle moulder is worth getting excited about.

The T14 is a heavy-duty, robust spindle moulder with convincing premium features. Take, for instance, its innovative, groundbreaking control system which opens up all networking possibilities to you. And then there is also its uniquely precise and robust machine construction. Added together, these two features will give you the best possible value for money.

The T14 is the ideal machine for any company – either as an affordable entry into the MARTIN world of moulding or as an effective way to expand your manufacturing options in trade and industry. With its individual customisation options, this is the perfect spindle moulder for a wide variety of applications.



Configure  
your T14.



## Specifications

### T14 spindle moulder

### T29 spindle and tilting arbor spindle moulder

Optional motor power	5.5 kW 7.5 kW   11.0 kW	5.5 kW 7.5 kW   11.0 kW   15.0 kW
Control system optional	7" touchscreen 11" iPad   12.9" iPad	7" touchscreen 11" iPad   12.9" iPad
Control panel	at eye level, rotatable	at eye level, rotatable
Spindle stroke	150 mm	150 mm
Spindle swivel	– –	T29 Fix: – T29 Flex: ± 46.00°
Rotational speeds	cont. rotational speed control 500 – 12,000 rpm	cont. rotational speed control 500 – 12,000 rpm
Table openings	255   205   161   106   74 mm	255   205   161   106   74 mm
Display resolution	0.05 mm	0.05 mm   0.01°
Repeat accuracy	± 0.025 mm	± 0.025 mm   ± 0.005°
Suction connections	2 x 120 mm	2 x 120 mm
Weight	approx. 950 – 1,300 kg	approx. 1,200 – 1,450 kg

Dimensions and specifications are subject to technical innovation and may change without prior notice. Illustrations may differ from the original. Please refer to the valid price list for binding technical features and equipment.

# T14

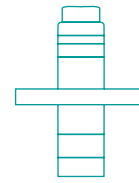

Spindle moulder

## Compact in class, premium in performance.

The T14 is our compact spindle moulder with all the premium features of a MARTIN machine. Take for instance, its state-of-the-art yet easy-to-use control system which opens up all networking possibilities to you. And then there is also its uniquely precise and robust machine construction. Added together, these two features will give you the best possible value for money.

The T14 is the ideal machine for any company – either as an affordable entry into the MARTIN world of moulding or as an effective way to expand your manufacturing options in trade and industry.

With its individual customisation options, this is the perfect spindle moulder for a wide variety of applications. The compact T14 spindle moulder is also worth getting excited about.

### T14 with accessories

T1404/1	11" Apple iPad Pro ConnectApp
T1404/10	OtterBox Defender Case 11"
T1406/1	CLASSIC ConnectApp
T1402/0	Motor rating 4.0 kW
T1431	Table extension, both sides
T1435	Fence for insert cutting
T1440	Centrex guard
T1442	Integral fence
T1443	AutoLock
T1445	Folding support
T1470	DornFix cutter arbor quick-change system
T1490	Cast-iron console
T1491	Comfort support leg
T1493_400	Variomatic 4N feed unit



# T29

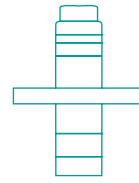

T29 Fix  
spindle moulder

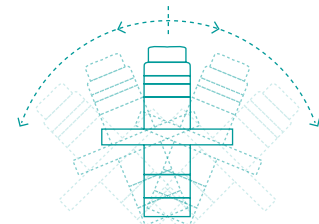

T29 Flex  
Tilting arbor  
spindle moulder

## Technology for today and tomorrow.

Setting up a spindle moulder, and particularly a tilting arbor spindle moulder, can be a major challenge. But that's not the case with the T29 Flex tilting arbor spindle moulder with its innovative, groundbreaking control system which lets you work highly efficiently thanks to its intelligent networking options.

For example, the new, innovative **ConnectControl** system offers you the possibility of centrally managing your tool data from the Production Planning department. This means that not just one machine, but all machines with access to **ConnectControl** technology, are always provided with the latest data. When carrying out complex profile settings with a tilted spindle, it is not unusual for set-up times to be reduced by up to 80%\*. Even profiles as basic as a rebate can be set up to 20%\*faster.

Thanks to the tool conversion system, which is also integrated in the standard version, it takes no time at all to set up complex moulding patterns, especially those with tilted spindles. This enables you to efficiently make use of the large tilting range of 2 x 46° – and you can follow your inclinations lock, stock and barrel.

Repeatability, process reliability and durability, combined with an intuitive, groundbreaking control system – those are the strengths of the T29.

### T29 with accessories

T2904/2 12.9" Apple iPad Pro ConnectApp

T2904/20 OtterBox Defender Case 12.9"

T2906/2 PREMIUM ConnectApp

T2902/2 Motor rating 11.0 kW

T2912 Motorised fence

T2913 Motorised infeed jaw

T2914 Motorised table ring

T2915 Motorised feed support

T2931 Table extension, both sides

T2935 Fence for insert cutting

T2940 Centrex guard

T2942 Integral fence

T2943 AutoLock

T2945 Folding support

T2970\_63F HSK 63 F cutter arbor quick-change system

T2923\_400 Variomatic 4N feed unit



# ConnectControl system.

**ConnectControl** is the umbrella term for the patented control concept that characterises the latest generation of formatting saws and spindle moulders from MARTIN. With **ConnectControl**, you get a uniquely designed, highly-powerful control concept that not only opens up completely new horizons to you in terms of machine operation, but also offers you the entire world of modern data exchange.



Everything you need to know about the ConnectControl.



# Machine operation: digital and networked.

## The latest **ConnectControl** technology.

With the high-resolution 7"-touchscreen **ConnectTouch** in modern 16:9 format, every spindle moulder can be operated quickly, easily and efficiently on all motorised axes. The attractively designed user interface supports you when inputting all dimensions; all displays refer to the tool you have specified – always to the point.

With the **ConnectPad** and the **ConnectApp** that runs on it, you can get more electronic support on the machine at any time, even at a later date. This solution not only makes machine operation easier, but it also opens up all the possibilities of networking and Internet connection to you.

Supplemented by the **ConnectDrive** Cloud solution, all data exchange paths with other software solutions in your Production Planning system are available to you.

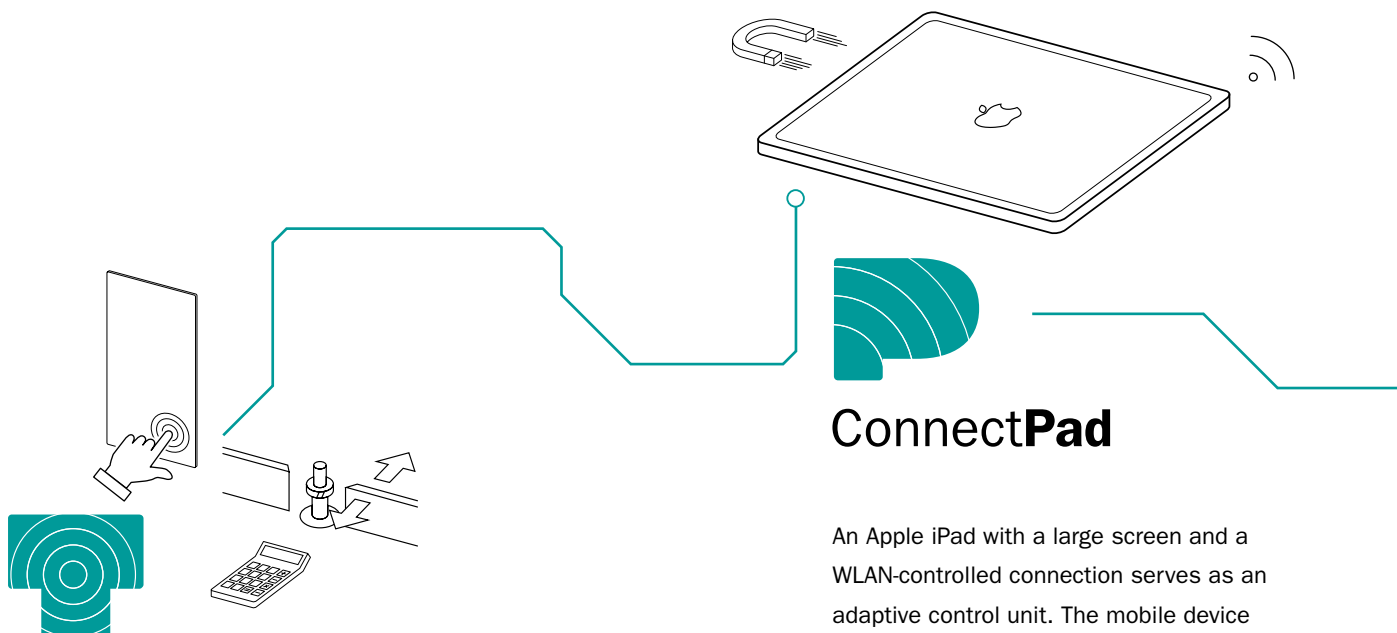

### ConnectTouch

The permanently integrated, touch-sensitive console serves as the operating unit and can control all the machine's functions.

### ConnectPad

An Apple iPad with a large screen and a WLAN-controlled connection serves as an adaptive control unit. The mobile device makes it possible to control the machine from any location.





## ConnectPad expands your range of actions.

The 12.9- or 11-inch Apple iPad Pro is attached magnetically to the control panel and can also be used in mobile applications any time. Thanks to the wireless networking of machine and Cloud, remote access of wood-processing machines is now possible for the first time. You now have mobile access to project data which enables particularly flexible production planning.



## ConnectApp: smart moulding.

In addition to the clearly arranged machine controls on the large screen of the **ConnectPad**, additional functions can also be operated with the **ConnectApp** such as tool and order management or section planning. Smart wizards also support carpenters in implementing special cuts such as tongue and groove cuts or tenoning.

Machine controls

Moulding settings

Order data management

User data

Remote maintenance



## Your workshop 4.0 can do that.

With the aid of **ConnectControl**, every machine can be networked quickly and easily. Similarly, the uncomplicated integration of further machines into the system makes it possible to control your entire workshop digitally. Thus, different machines can be taken into account from the project planning stage. The Cloud-supported control system with several devices also ensures extremely efficient cooperation between several users.



## Continuously adjustable.

SynchroDrive stands for the modern, new drive technology used in MARTIN spindle moulders. Thanks to the high-quality synchronous motors, not only is it possible to work in an extremely energy-efficient way, but above all, all moulding machines are equipped with a continuously adjustable rotational speed and large power reserves. The range of adjustment is between 500 and 12,000 rpm.

All spindle moulders are also always equipped with the patented MARTIN collision detection system.

The machine sets the spindle into a powerless rotation mode when positioning the motorised axis and can thus reliably detect any collisions and warn the user in good time.



# Robust and stable – the composite stand.



## An intelligent combination for outstanding work.

The machine frame on MARTIN spindle moulders is a stable, thick-walled composite structure of a type and perfection that is unique to MARTIN. This design was invented by Otto Martin and granted a utility model way back in the 1920s.

Following 100 years of continuous improvements, MARTIN still uses this very simple yet ingenious principle of frame construction today. The intelligent combination of the two materials, steel and concrete, creates a high-quality frame that is unparalleled in terms of stability, damping capacity and torsional rigidity. The vibrations that occur on every spindle moulder are absorbed far more effectively than with welded constructions. This frame provides the perfect basis for perfect work!



The unique structure  
of MARTIN composite  
stands results in  
incomparable  
stability.



## Close securely, open easily.

Fence jaws need to be moved on a regular basis in order to optimise the fence opening to suit the tool. But all too often, clamping is forgotten about afterwards and the jaws are damaged. The optional AutoLock fence jaw clamping system ensures secure clamping of standard and integral fence jaws in a simple and safe manner. The jaws are always clamped securely by spring force and the clamping is only released for setting with the easily accessible levers. Completely without any electrics or pneumatics.



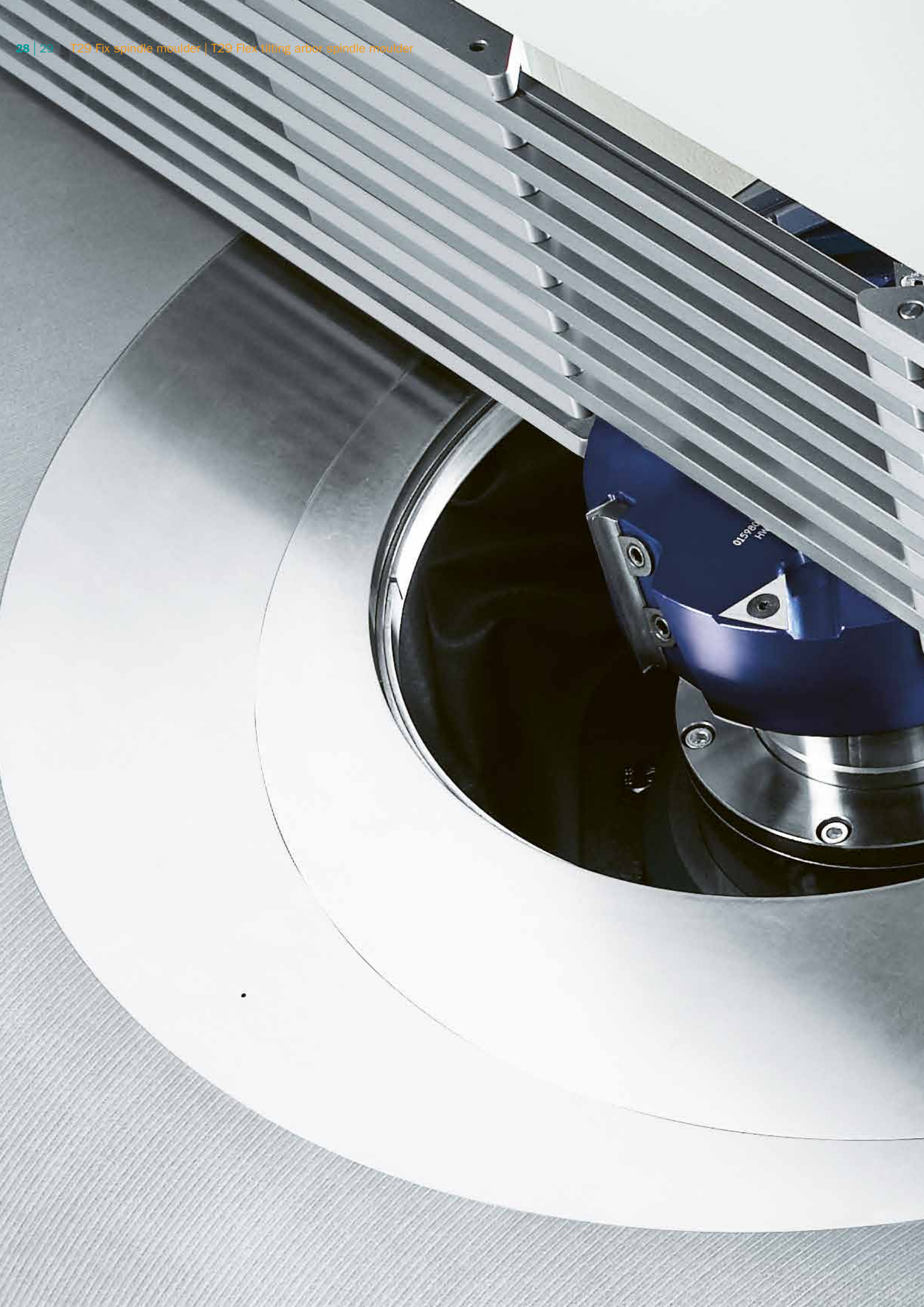

T14

T29

Optic



## Power supply

Your MARTIN machine needs to be supplied with the appropriate power supply, depending on the area of the world in which you are located.

Special voltage 3 ~	T14	T29
400 V / 50 Hz	Standard	Standard
210 – 240 V / 60 Hz	T14V_220	T29V_220
440 – 480 V / 60 Hz	T14V_440	T29V_440

## Motor rating

SynchroDrive stands for the modern, new drive technology used in MARTIN spindle moulders. Thanks to the high-quality synchronous motors, not only is it possible to work in an extremely energy-efficient way (IE5), but above all, all moulding machines are equipped with continuously adjustable rotational speed control and large power reserves. The tool's rotational speed can also be ideally adjusted to the requirements of the working process in the range from 500 to 12,000 rpm, even during operation. Thanks to the wide speed range, in addition to very slow-running profile grinding tools, small tools running at high speeds, such as end mills, can also be used at the ideal cutting speed.

Motor rating kW (hp)	T14	T29
5.5 (7.5)	T1402/0   standard	T2902/0   standard
7.5 (10)	T1402/1	T2902/1
11 (15)	T1402/2	T2902/2
15 (20)	–	T2902/3

# Operation & control

The innovative **ConnectControl** technology now brings more modern communication to your workshop. Thanks to the new operating system, you can now call up all data and information directly on your machine. Only MARTIN's new networked control system is able to do that.

The new high-resolution 7" **ConnectTouch** touch display allows you to control all motorised axes of the machine comfortably, quickly and efficiently. The attractively designed user interface supports you when making all settings, individually for each tool. This way, every setting is always quick and to the point.

Take it a step further. We offer you more mobility through a new cooperation with a real future: Used as a **ConnectPad** with the associated **ConnectApp**, an Apple iPad Pro provides even more extensive electronic support – at your new construction site, for example.

Both displays work together, synchronising tools, program data, work orders and so much more. Once online, through its connection with **ConnectDrive** – the MARTIN Cloud – the **ConnectPad** is the direct link to all order data from your Production Planning system, for example.

You can view or edit your data in real time, via a browser interface, on any Internet-capable terminal device. From your local system, you can, for example, transfer your order processing to the Cloud via interfaces, thus turning your machine into an intelligence beast.

The **ConnectPad** not only means that you can intuitively operate your MARTIN spindle moulder, but also, of course, that you have access to all the hardware and software possibilities that Apple offers with the iPad Pro and its apps. Customer emails, image data of the construction site, drawings of your workpieces or time recordings are always immediately available to you.

Do you use several spindle moulders in your workshop? If so, why not connect them together directly!

Control	T14	T29
7" (178 mm)	Standard	Standard
11" Apple iPad	T1404/1	—
12.9" Apple iPad	—	T2904/2
OtterBox Defender Case 11"	T1404/10	—
OtterBox Defender Case 12.9"	—	T2904/20
Document holder	T1405	T2905
ConnectApp	T14	T29
Classic operator level	T1406/1	T2906/1
Premium operator level	T1406/2	T2906/1



Control panel T14 | T29 | Standard

## Controlled axes

With up to seven electronically displayed and controlled axes, the MARTIN spindle moulders make a considerable contribution to increasing efficiency in your workshop. Each controlled axis is fully integrated into the control system and operates on the basis of the stored tool. As the machine knows what the geometry of this tool is, it not only positions it precisely to the point, but also integrates it into programs. Again, this reduces set-up times considerably. You can even set a profile as basic as a rebate up to 20% more quickly. Setting up the machine is no longer a question of trial and error – even the first workpiece fits perfectly in place!

### Cutting height (standard T14 / T29)

Electromotive positioning of the cutting height, which is included in the basic equipment, facilitates the setting up of a spindle moulder enormously. By simply specifying the required dimension, the machine moves precisely to the target dimension.

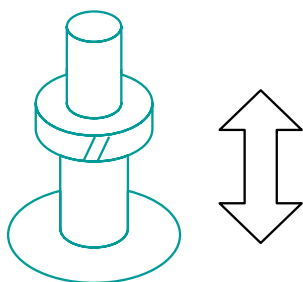

### Cutting angle (standard T29 Flex)

Electromotive positioning of the cutting angle is a feature of every T29 Flex. You enter the angular dimension with a resolution of 0.01° and the machine moves towards it. Ready, set... go.

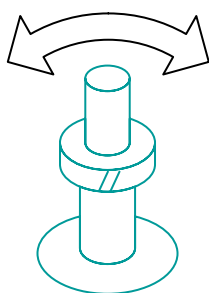

### Electromotive positioning of the fence

Electromotive positioning of the fence is an extremely useful addition to the T29, irrespective of whether it is a spindle moulder or a tilting arbor spindle moulder. Therefore, you can make the most frequent settings for a spindle moulder, the cutting height and depth, with the full support of the control system because the electronics are now responsible for doing what you once did with the hand wheel.

Thanks to the extremely high repeat accuracy of  $\pm 0.025$  mm, the fence settings are approached with pinpoint accuracy. Even critical settings, e.g. for cutting counter profiles, can be precisely positioned. As is already the case in the basic equipment, the cutting depth is also a component of any program and the control system carries out positioning according to the program specification.

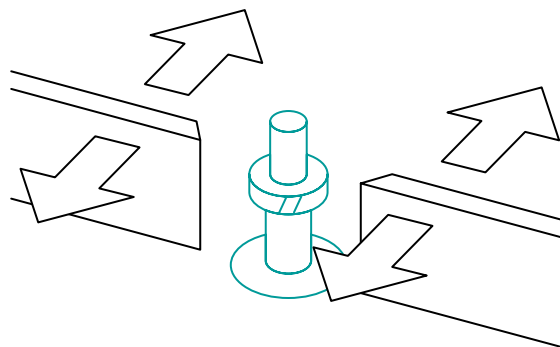

### Digital display of the infeed jaw position

The digital display of the infeed jaw position gives you the option of carrying out this setting very precisely, according to the digital display rather than according to a Vernier scale. The clear advantage is that you can now also store the position of the electronically-recorded infeed jaw position in the programs. Thus, you reap all the benefits of the control system; you simply need to take care of the setting yourself manually with the hand wheel as before. Incremental movement is also easily possible thanks to its integration in the control system.

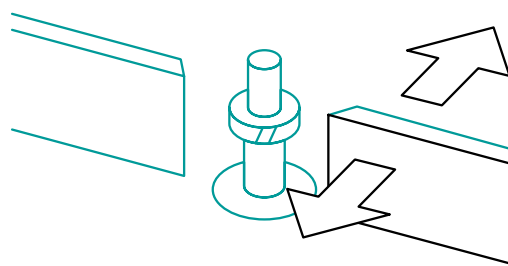

### Electromotive positioning of the right fence jaw

Wherever a purely digital display is no longer sufficient, electromotive positioning of the infeed jaw presents itself as an option. This feature, which is only available in conjunction with electromotive positioning of the fence, gives you complete control over the fence. You make all settings on the fence from the control system. This option is recommended for users who frequently carry out extensive moulding operations on the workpiece.

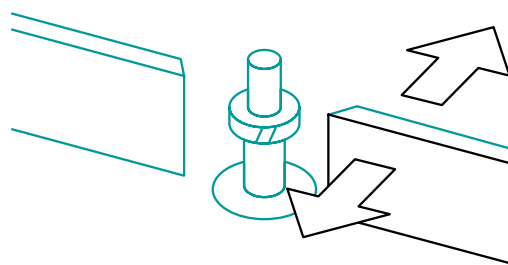

## Table extensions

Numerous options are available to increase the support of your workpiece on your machine. The extendable support, which is approx. 1,700 mm in length, is the first step in providing more support. You carry out the next step with the two-sided table extension and the approx. 3,000-mm-long extendable support. The table extensions are made of cast iron on both sides and connected to the machine without any transitions at all. The stable, extendable support provides support at the front and facilitates the processing of large components. If you opt for a sliding table, you will only require a table extension on the right, in which case the extendable support is shortened accordingly to approx. 2,100 mm.

The optional, retrofittable fence is a useful aid for insert cutting jobs. It enables you to carry out such jobs accurately and safely. These accessories can be mounted both on the right and on the left table extensions. In this way, you can set the start and stop point simply and precisely and with high repetition accuracy. When this option is not needed, simply fold the fence down under the table extension. The fence can be configured for insert cutting on all machines with a table extension.

### Table extensions

Front extendable workpiece support, 1,700 mm
Table extension, both sides, extendable support, 3,000 mm
Table extension, right side, extendable support, 2,100 mm
Fence for insert cutting

T14	T29
T1430	T2930
T1431	T2931
T1432	T2932
T1435	T2935



Table extension 1,700 mm | Txx30



Fence for insert cutting | Txx35



Table extension, right side | Txx32



Table extension, both sides | Txx31

## Fence jaws

The fence opening should always be closed in the firmly way so that the workpiece can be properly guided as it moves along the fence. This can be achieved with the tried and tested integral fence. The bars of the jaws, which are made of hard-coated aluminium, can be easily folded into position and released again, and the height position can also be varied.

The bar cassettes can be easily removed to allow working with a pre-set board.

If you opt for the standard jaws, the optional guide rails will help you to close the opening of this fence in the best possible way.

### Fence plates

Hard-coated MARTIN fence jaws in aluminium

Guide rails for MARTIN fence jaws

Integral fence

T14

Standard

T1441

T1442

T29

Standard

T2941

T2942



Integral fence | Txx42



Guide rails | Txx41



MARTIN fence plates | standard

## Arbor change systems

The DornFix standard quick-change system is the perfect solution for everyone wishing to adjust the arbor diameter time and again.

On the other hand, the HSK quick-change system is the number one choice for power users who often change the arbor of the complete arbor/tool units.

The system works fully tool-free and is compatible with the CNC processing centres of leading manufacturers. So you can use suitable CNC machining centre tools directly on the spindle moulder without any problem, thereby relieving this expensive machine from capacity-consuming traversing moulding tasks.

### Cutter arbor clamping system

DornFix quick-change system

HSK 85 PowerLock, compatible with Weinig PowerLock system, for example

HSK 63 F, compatible with the CNC machining centres of all leading manufacturers

T14

Standard

T1470\_85

T1470\_63F

T29

Standard

T2970\_85

T2970\_63F



SK40 cutter arbor clamping system | standard



HSK 63 F cutter arbor clamping system | Txx70\_63F



HSK 85 PowerLock cutter arbor clamping system | Txx70\_85

## Cutter arbors HSK 63

Choose the arbor(s) you require from a variety of diameters and clamping lengths. Please contact us if you are unable to find the arbor you require.

<b>Cutter arbor HSK63F</b>	T14	T29
∅ 30 mm, clamping length 80 mm	T297_310	T297_310
∅ 30 mm, clamping length 140 mm	T297_320	T297_320
∅ 35 mm, clamping length 140 mm	T297_326	T297_326
∅ 40 mm, clamping length 140 mm	T297_330	T297_330
∅ 1 1/4", clamping length 140 mm	T297_380	T297_380
∅ 1 1/2", clamping length 160 mm	T297_390	T297_390
Collet arbor HSK 63F	T29630	T29630

## Cutter arbors HSK 85

Choose the arbor(s) you require from a variety of diameters and clamping lengths. Please contact us if you are unable to find the arbor you require.

<b>HSK 85 PowerLock cutter arbor</b>	T14	T29
∅ 30 mm, clamping length 80 mm	T2971	T2971
∅ 30 mm, clamping length 140 mm	T2972	T2972
∅ 35 mm, clamping length 140 mm	T2972_326	T2972_326
∅ 40 mm, clamping length 140 mm	T2973	T2973
∅ 1 1/4", clamping length 140 mm	T2978	T2978
∅ 1 1/2", clamping length 160 mm	T2979	T2979

## Sliding table for mortising work

For the safe and precise cutting of mortises, tenons and counter profiles, we offer you two sliding tables.

Smaller tenon, mortising or counter profile work can be performed easily on the small sliding table with a 570 mm working path. The sliding carriage is simply mounted on the machine table in front of the fence, and runs smoothly on high-quality ball bearings. The sliding table is equipped with a mitre fence (can be pivoted on both sides by 45°) and with a powerful, quickly adjustable eccentric clamping device with a pressure plate.

The larger table is also suitable for heavy-duty processing, as is usual in window or door manufacturing, for instance.

The solid table offers a large and secure support and can be rotated in both directions by up to 45°, and the fence can even be rotated by up to 65°. So, even diagonally cut workpieces such as special window profiles can be safely clamped during processing.

The sliding table has a large working path of 1,400 mm, to enable even large workpieces to be safely processed. The guard safely holds tools of up to 350 mm in diameter.

If the sliding table is not required, it forms a perfect left table extension, as it can be lowered to the machine table level. The guide bar can be easily moved to the back where it fits flush with the front of the machine.

### Sliding table

Sliding table for light tenons and mortising work

Sliding table for heavy-duty mortising and counter profile work

T14

T29

T1485

T2985

T1480

T2980



Lightweight sliding table | Txx85



## Feed support | feed units

A feed unit is recommended for more effective operational safety on the spindle moulder. It quickly and comfortably transports the workpiece past the tool. To assemble a classic feed support on the spindle moulder, we recommend the corresponding assembly console which is mounted on the left of the machine table.

The winning feature of the comfort feed support is that it can be easily folded to the side and positioned with the MemoLock system. This means that, after folding it away, for example for a tool exchange, the feed latches back again exactly in the starting position. The height settings are very precise thanks to the digital height indicator, and height adjustment is quick and easy for the operator to carry out. Large locking levers ensure that the feed support can be clamped quickly and easily.

The powerful Variomatic feed unit will win you over with its continuous speed control and simple changeover from horizontal to vertical use. The changeover from right-handed to left-handed as well as forwards/backwards is another feature of this feed. The 3N version is equipped with 3 rollers, the 4N with 4 rollers. These feeds are suitable for the comfort feed support.

### Feed support | feed units

	T14	T29
Cast console for assembling a feed support	T1490	T2990
Comfort feed support	T1491	T1491
Variomatic 3N feed unit	T1492_400	T1492_400
Variomatic 4N feed unit	T1493_400	T1493_400



Cast-iron console | Txx90

## Feed units for MARTIN feed support

The options described here are exclusively available for the T29 in conjunction with the T2915 option, the feed support.

You have the choice between a 3- and a 4-roller Variomatic feed, the speed of which is continuously adjustable during operation. Both feeders can be quickly and easily changed from vertical to horizontal pressure. The feeders are the perfect complement to the MARTIN feed support.

You can select electronically adjustable feed speeds for both feeds. Then, enter all parameters for the workpiece transport directly from the control system. The control range lies between 2 and 24 m/min.

### Feed units for MARTIN feed support

Variomatic 3N feed unit, 3-roller feed, continuously adjustable mechanically from 3 – 17 m/min

Variomatic 4N feed unit, 4-roller feed, continuously adjustable mechanically from 3 – 17 m/min

Electronically adjustable feed speed

T29

T2922\_400

T2923\_400

T2996



Variomatic 4N feed unit on feed support | T2923\_400 + T2915



Variomatic 4N feed, electronically variable | T2923\_400 + T2996 + T2915

### T14 tilting arbor spindle moulder

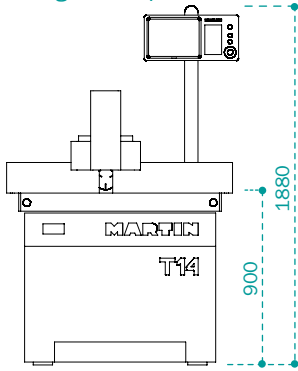

T14 | Side view

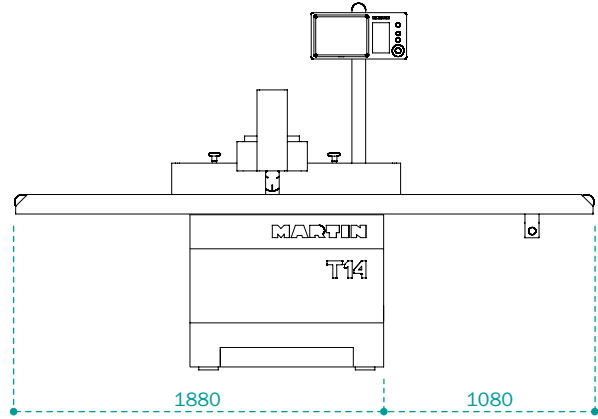

T14 with table extension | Front view

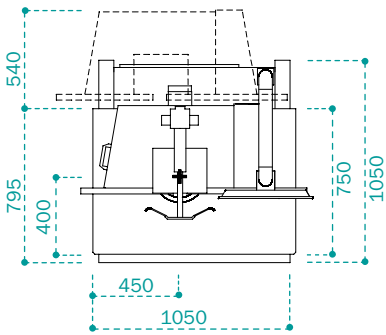

T14 | Plan view

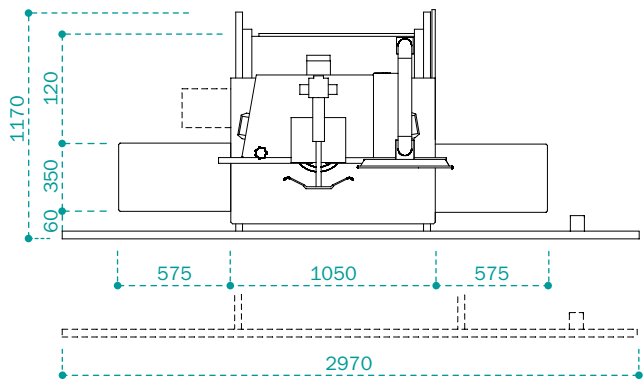

T14 with table extension | Plan view

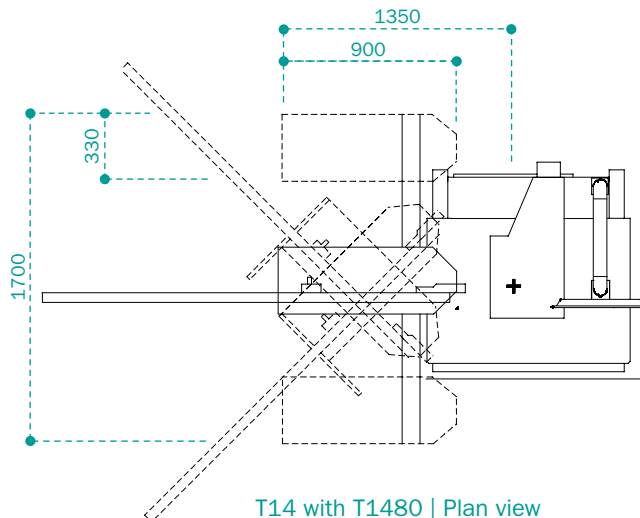

T14 with T1480 | Plan view

**Visit us:**

Website



Facebook



Instagram



YouTube



Brochure



Contact us at  
+49 (0) 8332 911 - 0  
[sales@martin.info](mailto:sales@martin.info)

**MARTIN**