



RÖCHLING

High Performance Plastics

Polystone® M (PE-UHMW / PE 1000)

Extrudierte Profile
Extruded profiles

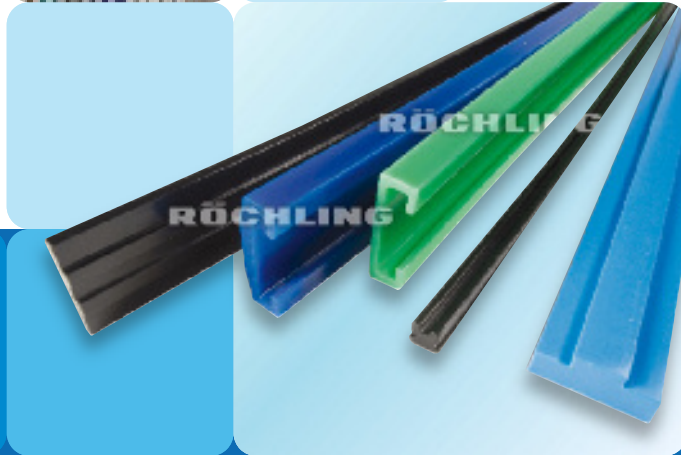

09/2013



Polystone®

Thermoplastische Kunststoffe
Thermoplastics

Inhalt Content

	Seite Page		Seite Page
Index	3	Z-Profil / Z-profiles	16
Röchling-Gruppe		L-Profil / L-profiles.....	17
Röchling Group	4-5	Klemmprofile / Clamp-profiles.....	18-19
Einzigartige Auswahl		T-Profil / T-profiles.....	20-21
Unique selection	6	U-Profil / U-profiles	22-25
Werkstoffkompetenz		C-Profil / C-profiles.....	26-29
Competence in materials	7-9	Halbrund-Profil / Round bar cover.....	30
Verarbeitungskompetenz		Rohre / Tubes.....	31
Competence in machining	10-12	Seitenführungsprofil / Side guide profile	32
Wettbewerbsvorteil durch Innovation		Vierkantprofil / Square-profiles.....	33
Forschung und Entwicklung		Clip-Profil / Clip-profiles.....	34
Competitive advantages through		Spezial-Profil / Special-profiles	35-43
innovation	13	Bandmaterial / Wear strips.....	44
Branchenkompetenz		Folien / Film	45
Competence in industry			
Kundenanwendungen verstehen			
Understanding customer applications	14		
Neuer Werkstoff LubX®			
New material LubX®	15		



Profil Seite
Profile Page

R1	20	R77	34	R152	16	R224	38	R303	40	R376	42	R505	29
R2	20	R78	32	R153	37	R225	38	R304	24	R377	29	R506	29
R3	20	R79	20	R154	17	R226 (W090)	26	R306	20	R378	27	R507	29
R4	20	R80	36	R155	18	R227 (W016)	26	R307	31	R380	42	R508	29
R5	20	R81	36	R156	34	R229	24	R308	31	R381	27	R509	29
R6	20	R82	36	R157	34	R230	38	R309	40	R383	31	R510	29
R7	16	R85	36	R158	20	R231	22	R310	16	R384	39	R511	31
R7.1 (W055)	17	R86	36	R160	26	R232	38	R311	40	R385	42	R513	42
R8	16	R87	34	R161	27	R233	38	R312	25	R386	24	R515	36
R9	16	R88	35	R162	37	R234	23	R313	40	R387	19	R516	39
R10	18	R89	35	R166	37	R235	23	R314	31	R388	42	R519	19
R10.1 (W081)	18	R90	34	R167	23	R236 (W009)	23	R315	40	R389	42	R521	42
R11	30	R91	36	R168	37	R237	18	R317	40	R390	31	R522	42
R12 (G003)	35	R92	36	R169	23	R238	38	R318	40	R391	39	R523	24
R13	32	R93	36	R170	18	R240 (G094)	28	R319	40	R392	42	R527	23
R14	32	R94 (W015)	26	R171	37	R241	23	R320	40	R393	19	R528	42
R15	26	R95	30	R172	26	R242	38	R321	40	R394	42	R529	23
R16 (W013)	26	R96	36	R173	22	R244	26	R322	41	R395	27	R530	23
R18	26	R97 (G017)	30	R174	37	R245	27	R323	41	R396	27	R531	42
R19	26	R98	22	R175	37	R246	22	R324	41	R397	27	R532	42
R21 (W104)	26	R99	37	R176	33	R247	23	R325	41	R398	40	R533	26
R22 (W034)	28	R100	37	R177	37	R249	34	R326	41	R399	19	R534	19
R23 (W010)	23	R102	20	R178	37	R250	34	R327	41	R401 (PGR1)	32	R535	16
R24	22	R103	18	R179	37	R251	38	R328	25	R402 (PGR2)	32	R536	26
R26	23	R104	37	R180	18	R252	39	R329	28	R403 (PGR3)	32	R537	42
R28	24	R105	37	R181	37	R253	39	R330	40	R404 (W004)	17	R539	40
R29	24	R106	37	R182	17	R254	29	R331	27	R405 (W005)	17	R540	42
R30	24	R107	18	R183	33	R255	22	R332	41	R406 (W056)	16	R541	41
R31	35	R108	18	R184	33	R256	22	R333	25	R407 (W047)	18	R542	17
R32	35	R110	37	R185	38	R258	39	R334	41	R408 (W068)	22	R543	42
R33	32	R111	28	R187	16	R259	39	R335	39	R409 (W094)	41	R545	27
R35	32	R112 (W048)	26	R188	27	R260 (W042)	27	R336	39	R410 (G041)	41	R546	19
R36	35	R113 (G021)	28	R189	38	R261	39	R337	41	R411 (W091)	20	R547	19
R37	35	R115	28	R190	17	R262	39	R338	27	R412 (W112)	28	R548	29
R38	35	R116	35	R191	24	R263	39	R339	18	R413 (W093)	23	R549	43
R39	35	R117	22	R192	29	R264 (G002)	27	R340	18	R414 (G014)	30	R550	43
R40	35	R119	18	R193	38	R265	26	R341	27	R415 (G015)	30	R551	39
R41	35	R120	26	R194	38	R266	18	R342	29	R416 (W096)	28	R552	16
R42	24	R121	37	R195	38	R267	17	R343	29	R417 (W097)	23	R554	28
R43	35	R122	37	R196	34	R268	32	R344	22	R418 (W018)	20	R555	38
R45	35	R123	22	R197	34	R269 (W069)	22	R345	24	R419 (W019)	21	R556	16
R46	36	R124	16	R198	38	R272 (W076)	28	R346	31	R420 (W020)	20	R557	24
R48	36	R125	17	R199	38	R274 (W033)	39	R347	31	R421 (W021)	17	R558	32
R49	36	R126	28	R201	38	R275	18	R348	31	R422 (W122)	19	R559	43
R51	20	R127	26	R202	38	R276	26	R350	41	R424 (W114)	16	R560	41
R51.1	20	R128 (W065)	22	R203	33	R277	39	R351	19	R425 (G025)	30	R561	43
R53	36	R129	27	R204	38	R278	39	R352	19	R426 (W062)	20	R564	43
R54	17	R130	27	R205	16	R279	39	R353	28	R427 (W127)	23	R565	40
R55	17	R131	27	R206		R280	39	R354	41	R428 (G028)	28	R566	34
R56	36	R132	22	(W008/W116)	18	R281	26	R355	41	R429 (W059)	17	R567	40
R58	36	R133	20	R207	32	R282	39	R356	41	R430 (W100)	28	R568	43
R62	29	R134	35	R208	32	R283 (G016)	30	R357	41	R431 (G051)	27		
R63	22	R135	35	R210	22	R284	39	R359	17	R432 (W098)	28		
R64	28	R136	35	R211	16	R285	40	R360	42	R433 (W103)	21		
R65 (G008)	36	R137	17	R212	35	R286	40	R361	42	R435 (W115)	17		
R66	36	R138	18	R213	24	R287	40	R362	18	R436 (W063)	16		
R67 (G007)	36	R139 (G071)	35	R214	27	R288	24	R363	28	R437 (W057)	21		
R68	24	R140	20	R215	38	R289	27	R364	42	R441 (W141)	23		
R69	33	R141	17	R216	22	R293	16	R365	36	R442 (W142)	41		
R70	33	R143	35	R217	18	R294	40	R366	31	R443	28		
R71	33	R144	37	R218 (G007)	18	R295 (W110)	20	R367	31	R485	32		
R72	33	R146	22	R219	23	R296 (W111)	22	R368	31	R500	24		
R73	33	R148	22	R220	23	R297	32	R369	24	R501	41		
R74	33	R149	20	R221	23	R300	28	R372	23	R502	42		
R75	33	R150	24	R222	24	R301	28	R373	26	R503	29		
R76	24	R151	17	R223	24	R302	40	R374	19	R504	29		

Röchling



Kompetenz in Kunststoff

Competence in Plastics





Röchling Group

Geschäftsbereich/Business Division High-Performance Plastics

-  Röchling Engineering Plastics
-  Röchling Sustaplast

Geschäftsbereich/Business Division Automotive Plastics

-  Röchling Automotive
-  Röchling Technical Parts

Die Röchling-Gruppe ist eine weltweit agierende Kunststoff-Gruppe. Mit rund 7.300 Mitarbeitern an 60 Standorten in 20 Ländern zählt Röchling heute international zu den führenden Unternehmen auf dem Gebiet der Kunststoffverarbeitung.

The Röchling Group is a global plastics group. With some 7,300 on the workforce at 60 locations in 20 countries, Röchling today ranks internationally amongst the leading enterprises in the field of plastics processing.

Mit ihren beiden Geschäftsbereichen Hochleistungs-Kunststoffe und Automobil-Kunststoffe erwirtschaftet die Gruppe auf dem amerikanischen, dem europäischen und dem asiatischen Kontinent einen Umsatz von über 1,2 Milliarde Euro.

With their two divisions, High-Performance Plastics and Automotive Plastics, the Group, with its companies on the American, European and Asian continents, generates an annual turnover of around 1.2 billion euros.

Röchling High-Performance Plastics

Der Geschäftsbereich High-Performance Plastics deckt innerhalb der Röchling-Gruppe den Bereich der Hochleistungs-Kunststoffe ab. Mit weltweiten Tochtergesellschaften und Vertriebsniederlassungen hat die Röchling High-Performance Gruppe international eine führende Stellung in der Herstellung und Zerspaltung thermoplastischer und duroplastischer Kunststoffe für die Investitionsgüterindustrie.

Röchling High-Performance Plastics

The High-Performance Plastics business unit covers the range of high-performance plastics within the Röchling Group. With world-wide subsidiaries as well as sales and distribution offices, the Röchling High-Performance Group has a leading position internationally in producing and machining thermoplastics and composites for the capital-goods industry.

Das Produktprogramm umfasst extrudierte, polymerisierte und gepresste Halbzeuge wie Rundstäbe, Flachstäbe und Tafeln, Folien, Hohlstäbe/Rohre, extrudierte Profile, Gusspolyamid-Sonderteile, faserverstärkte Kunststoffe und zerspannte Fertigteile.

The product range covers extruded, polymerised and pressed semi-finished products, such as round rods, flat rods and sheets, foils, tubes, extruded profiles, special polyamide cast parts, fibre-reinforced plastics and machined finished components.



Business Unit Machined Components

Überall in Ihrer Nähe

Everywhere close to you

Die Business Unit Machined Components im Geschäftsbereich Hochleistungs-Kunststoffe ist mit über 800 Mitarbeitern der weltweit führende Zerspamer von Kunststoffen. Die flexiblen Unternehmen sind auf die Herstellung qualitativ hochwertiger Fertigteile für nahezu jeden Bereich der Investitionsgüterindustrie spezialisiert. Neben zerspannten Kunststoffteilen bietet die BU Machined Components das weltweit größte Lieferprogramm von extrudierten Profilen aus thermoplastischen Kunststoffen, die auf PE-UHMW basieren. Gemeinsam mit dem Kunden erarbeiten wir optimale Lösungen, die effizient umgesetzt werden.

Ihre Ideen werden zu hochwertigen Komponenten

Das einzigartige, internationale Unternehmensnetzwerk bietet Ihnen die Werkstoffkompetenz eines der innovativsten Hersteller von Kunststoffhalbezeugen, außergewöhnliches Branchen-Know-how und einen Maschinenpark, der weltweit einmalig ist.

Profitieren Sie von den Synergien der weltweiten Standorte der Business Unit. Wir freuen uns auf Ihre anspruchsvollen Herausforderungen.

Within the High-Performance Plastics Division, the Business Unit Machined Components has over 800 employees and is the world-wide leader in machining plastics. The flexible companies have specialised in the manufacture of high quality machined components for virtually every sector of the capital goods industry. Besides machined parts made, the BU Machined Components offers the world's probably largest product range of extruded profiles made of thermoplastics, which are based in particular on PE-UHMW. We develop optimum solutions jointly with the customer, then realise them efficiently.

Your ideas become high quality components

This one-of-a-kind, international network of companies provides you with the material expertise of one of the most innovative manufacturers of semi-finished plastic parts, as well as outstanding industry know-how and machinery that is unparalleled in the world.

You benefit from the synergies of the global locations of the Business Unit. We look forward to meeting your mostchallenging needs.

Röchling-Gruppe

Globale Präsenz: 60 Unternehmen in 20 Ländern

Röchling Group

Global presence: 60 companies in 20 countries

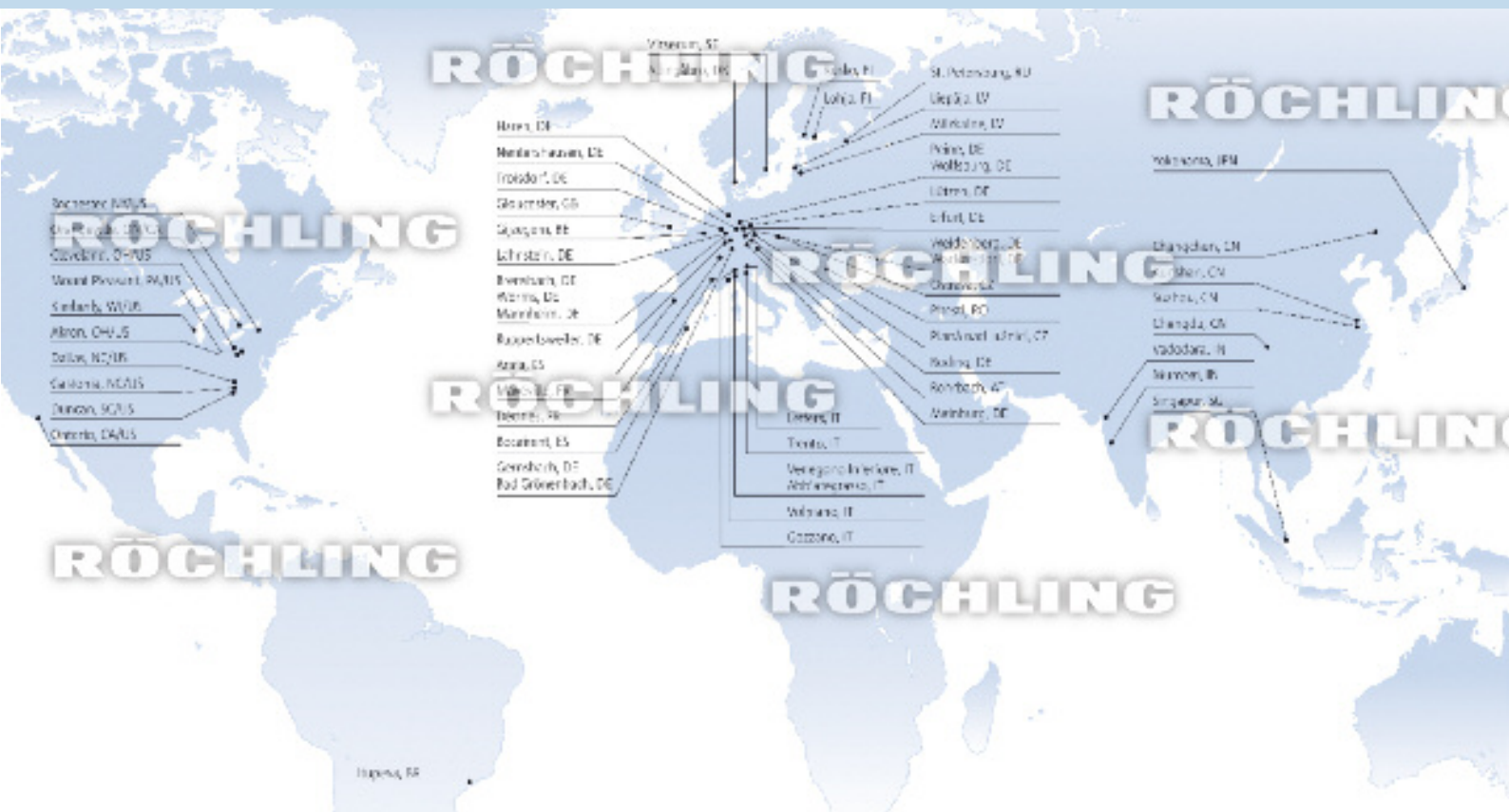

Kompetenz in Kunststoff / Competence in plastics

Einzigartige Auswahl an extrudierten Profilen aus Polystone® M (PE-UHMW / PE 1000)

Unique selection of extruded profiles made of Polystone® M (PE-UHMW / PE 1000)

Einzigartige Auswahl: Nahezu 600 Profil-Querschnitte

Entwickler und Hersteller von Anlagen und Maschinen in der Förder- und Handhabungstechnik, der Lager- und Verpackungsindustrie sowie der Getränke- und Abfüllindustrie setzen auf Bauteile aus thermoplastischen Kunststoffen. Extrudierte Profile sind dabei ein wichtiger Bestandteil. Sie sind dort im Einsatz, wo gute Gleiteigenschaften bei gleichzeitig großer Verschleiß- und Abriebfestigkeit verlangt werden. Mit derzeit fast 600 unterschiedlichen Querschnitten bietet Röchling eine im Markt wohl einzigartige Auswahl an Profilen aus PE-UHMW.

Ob Abdeck- oder Clip-Profil, Z-, L-, U-, C-, T- oder Vierkantprofil, ob komplexe Geometrien, spezielle Oberflächenstrukturen oder dünne Wandstärken – Ihnen steht das umfangreichste Fertigungsprogramm an extrudierten Standardprofilen oder individuell für Sie gefertigten Sonderprofilen zur Verfügung. Unser erfahrenes Team berät Sie umfassend bei der Auswahl des richtigen Querschnitts.

Unique selection: almost 600 profile cross-sections

Developers and manufacturers of plant and machinery used in conveyor and material handling technology, the storage and packaging industry and the bottling and beverage industry rely on thermoplastic components. Extruded profiles are a key part of these. They are used wherever good slide characteristics are demanded alongside high wear and abrasion resistance. With almost 600 different cross-sections now available, Röchling offers what is probably the widest selection of PE-UHMW profiles on the market.

Whether you need cover- or clip-profiles, Z-, L-, U-, C-, T- or square-profiles, complex geometries, special surface structures or thin wall thicknesses, you can choose from the most extensive range of extruded standard profiles or special profiles customised just for you. Our experienced team will provide comprehensive advice to help you select the right cross-section.



Prozess der Profilextrusion

Bei der Profilextrusion wird der Rohstoff – eine Pulvermischung aus PE-UHMW, Additiven und Farbpigmenten – unter hohem Druck durch ein beheiztes Werkzeug gedrückt. Das Material wird plastisch und nimmt die Form des Werkzeuges an. Nach Verlassen des Werkzeuges ist ein kontrolliertes Abkühlen wichtig, um innere Spannungen auszugleichen und ein Verziehen des Profils zu vermeiden. Bei hoher Temperatur dehnt sich der Werkstoff aus und zieht sich beim anschließenden Erkalten wieder zusammen. Daher ist die exakte Auslegung des Werkzeuges besonders wichtig, um im fertigen Profil die Form und die vorgegebenen Toleranzen einzuhalten.

The profile extrusion process

In profile extrusion, the raw material – a powder mixture of PE-UHMW, additives and colouring pigments – is forced through a heated tool under high pressure. The material becomes plastic and takes on the form of the tool. After leaving the tool, controlled cooling is essential in order to equalize internal stresses and prevent the profile warping. The material expands at high temperature and then contracts again as it subsequently cools down. This means it is particularly important to configure the tool precisely so that the form and prescribed tolerances are kept in the finished profile.

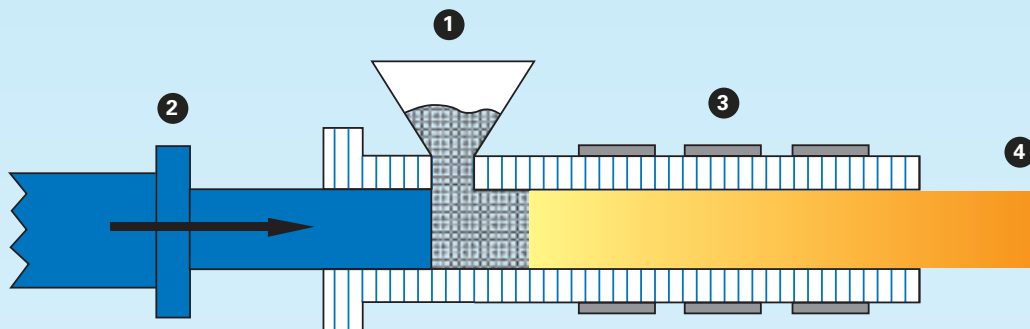

- 1 Trichter:** Polystone® M (PE-UHMW / PE 100) wird in Form einer Pulvermischung über einen Trichter zugeführt
Funnel: Polystone® M (PE-UHMW / PE 100) is fed in as a powder mixture through a funnel
- 2 Hydraulikzylinder:** Der Kolben transportiert das Pulver unter hohem Druck in das Werkzeug
Hydraulic cylinder: The piston transports the powder into the tool under high pressure
- 3 Werkzeug:** Das beheizte Werkzeug gibt dem Profil den gewünschten Querschnitt
Tool: The heated tool gives the profile its desired cross-section
- 4 Abkühlen und Zuschneid:** Abkühlen Ihres Profils und Zuschneiden auf die gewünschte Länge
Cooling and blank cutting: Your profile is cooled and cut to the desired length

Extrudierte Profile aus Polystone® M (PE-UHMW / PE 1000)

Extruded profiles made of Polystone® M (PE-UHMW / PE 1000)

Polystone® M (PE-UHMW / PE 1000)

Polystone® M ist ein Werkstoff mit außergewöhnlichen Eigenschaften. Das ultrahochmolekulare Polyethylen löst als extrudiertes Profil Reibungs-, Verschleiß- und Materialflussprobleme in zahlreichen technischen Anwendungen.

Die moderne Förder- und Handhabungstechnik, Lager- und Verpackungssysteme oder die Getränke- und Abfüllindustrie kommen heute ohne diesen Hochleistungswerkstoff nicht mehr aus.

Polystone® M (PE-UHMW / PE 1000)

Polystone® M is a material with exceptionally properties. As an extruded profile, this polyethylene of ultrahigh molecular weight solves problems of friction, wear and material flow in countless technical applications. Modern conveyor and material handling technology, storage and packaging systems and the bottling and beverage industry could not do without this high-performance material today.

Hervorragende Gleiteigenschaften

Dank des geringen Gleitreibungskoeffizienten können extrudierte Profile aus Polystone® M die **benötigte Antriebsenergie** in Fördersystemen **reduzieren** und die **Stabilität** der **Prozesse erhöhen**. Dabei verfügt Polystone® M über dauerhaft selbstschmierende Eigenschaften.

Outstanding slide characteristics

Their low slide friction coefficients enable extruded profiles made of Polystone® M to **reduce** the **drive energy required** in conveyor systems and **increase** the **stability of processes**. Polystone® M also has particularly long-lasting self-lubrication properties.



Extreme Verschleißfestigkeit / Lange Betriebsdauer

Aufgrund der extrem hohen Verschleißfestigkeit halten extrudierte Profile aus PE-UHMW hohen Beanspruchungen langfristig stand.

Extreme wear resistance / long service life

Extruded profiles made of PE-UHMW can withstand high long-term stresses thanks to their extremely high wear resistance.

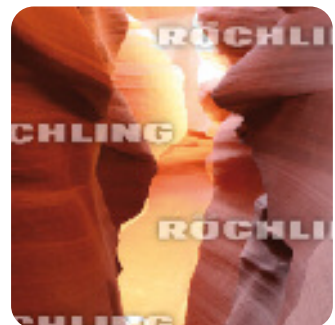

Dauer-Einsatztemperatur von -250 bis +80° Celsius

Extrudierte Profile von Röchling sind in einer Vielzahl an Anwendungen mit hohen und sehr niedrigen Temperaturen im Einsatz: beispielsweise in Spiralfröstern oder Kühlhäusern.

Continuous operating temperature from -250 to +80° Celsius

Extruded profiles from Röchling are used in a large number of applications involving high and very low temperatures, such as spiral frosters or cold stores.



Extrudierte Profile aus Polystone® M (PE-UHMW / PE 1000)

Extruded profiles made of Polystone® M (PE-UHMW / PE 1000)

Weitere Eigenschaften von extrudierten Profilen aus Polystone® M:

- Sehr gute Beständigkeit gegen Chemikalien
- Fast keine Wasseraufnahme
- Hohe Widerstandsfähigkeit gegen Bruch oder Rissbildung
- Nur geringfügige Anhaftung an den Oberflächen

Zahlreiche Modifikationen möglich:

- Antistatisch (AST)
- Flammschützend ausgestattet
- Antimikrobiell ohne Einsatz toxischer Zusätze
- Glaskugelgefüllt
- Nahezu jede gewünschte Farbe herstellbar
- Gleitmittelmodifiziert
- Hitzestabilisiert (reduzierte Wärmealterung)
- UV-stabilisiert

Other properties of extruded profiles made of Polystone® M:

- Very high resistance to chemicals
- Almost no moisture absorption
- High resistance to fracture or cracking
- Only slight adhesion to surfaces

Numerous modifications possible:

- Antistatic (AST)
- Flame retardant finish
- Antimicrobial without the use of toxic additives
- Glass bead filling
- Almost any colour desired can be produced
- Lubricant modified
- Heat stabilised (reduced heat ageing)
- UV resistant



Umweltschonend durch 100%ige Recyclingfähigkeit

Environmentally friendly – 100% recyclable



Lebensmitteltauglichkeit bereits für viele Rezepturen verfügbar (gem. EU 10/2011 und FDA)

Suitability for use with foods already available for many recipes (as per EU 10/2011 and FDA)



Hohe Schlagzähigkeit

High impact strength

Verarbeitungskompetenz / Competence in machining

Extrudierte Profile aus Polystone® M (PE-UHMW / PE 1000)

Extruded profiles made of Polystone® M (PE-UHMW / PE 1000)

Einzigartige Fertigungsmöglichkeiten

Wir fertigen Ihre Profile auf modernsten Extrusionsanlagen mit im Markt einzigartigen Fertigungsmöglichkeiten: Ob Abdeck- oder Clip-Profil, Z-, L-, U-, C-, T- oder Vierkantprofil, ob komplexe Geometrien, dünne Wandstärken oder hochglänzende und besondere Oberflächenstrukturen – Ihnen steht das im Markt wohl umfangreichste Fertigungsprogramm an Standardprofilen oder für Sie exklusiv gefertigten Sonderprofilen zur Verfügung.

Beratung und eigener Werkzeugbau

Bei Entwicklung und Design Ihres Spezialprofils nach Ihren individuellen Vorgaben beraten Sie unsere erfahrenen Techniker und Werkzeugbauer, um ein optimal funktionierendes Ergebnis für Ihre Anwendung zu erzielen. Unser eigener Werkzeugbau bietet dabei höchste Präzision, Schnelligkeit und eine optimale Abstimmung des Werkzeugs auf den verwendeten Kunststoff.

Unique manufacturing options

We manufacture your profiles on the very latest extrusion systems with unique manufacturing options: whether you need cover- or clip-profiles, Z-, L-, U-, C-, T- or square-profiles, complex geometries, thin wall thicknesses or high-gloss and special surface structures, you can choose from the most extensive range of standard profiles or special profiles customised exclusively for you.

Consulting and in-house toolshop

Our experienced engineers and toolmakers will give you advice on how to design and develop your special profile to meet your own particular requirements so that you achieve the outcome that works best for your application. Our in-house toolshop offers maximum precision, speed and the optimum configuration of the tool to the plastic used.

Zahlreiche Vorteile

- Nahezu 600 Querschnitte
- In den meisten Fällen deutlich günstiger als das zerspannte Profil
- Eigener Werkzeugbau
- Komplexe Geometrien möglich
- Querschnitte realisierbar, die nicht spanabhebend hergestellt werden können
- Dünne Wandstärken ab 1,5 mm
- Keine Längenbegrenzung
- Kein Materialverlust
- Homogene, glatte Oberfläche

Numerous advantages

- Almost 600 cross-sections
- In most cases much cheaper than machined profiles
- In-house toolshop
- Complex geometries possible
- Possibility of cross-sections that cannot be produced by machining processes
- Thin wall thicknesses from 1.5 mm
- No limits on length
- No loss of material
- Smooth, homogeneous surface

Die Fertigung von Profilen im Extrusionsverfahren bietet im Vergleich zur spanabhebenden Herstellung je nach Profilquerschnitt **Vorteile** hinsichtlich der **Wirtschaftlichkeit** und **technischen Realisierbarkeit**.

Depending on the profile cross-section, the manufacture of profiles in an extrusion process offers **advantages** over machining processes in terms of **economy** and **technical feasibility**.

Wirtschaftlichkeit / Economy

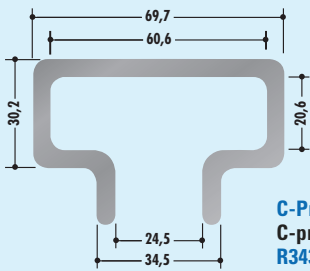

**C-Profil
C-profile
R343**

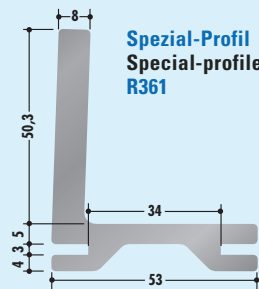

**Spezial-Profil
Special-profile
R361**

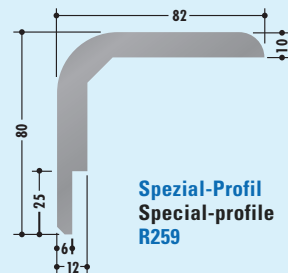

**Spezial-Profil
Special-profile
R259**

Beispiele für Profile, die bei spanabhebender Fertigung einen hohen Materialverlust und Zerspanungsaufwand verursachen und deswegen wirtschaftlich nicht gefertigt werden können. Die Extrusion bietet hier einen klaren Vorteil, da Profile mittels eines Formwerkzeuges produziert und somit ohne jeglichen Materialverlust hergestellt werden.

Examples of profiles that entail significant loss of material and machining expenditure in machining processes and so cannot be manufactured cost-effectively. Extrusion offers a clear advantage here as profiles can be produced using a die, meaning there is no loss of material whatsoever.

Technische Realisierbarkeit / Technical feasibility

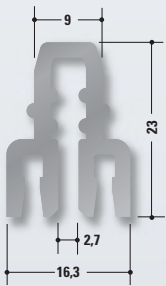

**Spezial-Profil
Special-profile
R242
Maßstab 1:1
Scale 1:1**

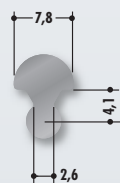

**Spezial-Profil
Special-profile
R355
Maßstab 1:1
Scale 1:1**

Beispiele für Profile, die aufgrund der Geometrie spanabhebend nicht oder nur sehr aufwendig hergestellt werden können. Im Extrusionsverfahren gibt es diesbezüglich kaum Beschränkungen und es kann daher fast jede erdenkliche Profilform problemlos realisiert werden.

Examples of profiles whose geometry makes it impossible or complex to produce in machining processes. There are hardly any restrictions in this regard in an extrusion process, so almost every conceivable profile form can be realised without any problem.

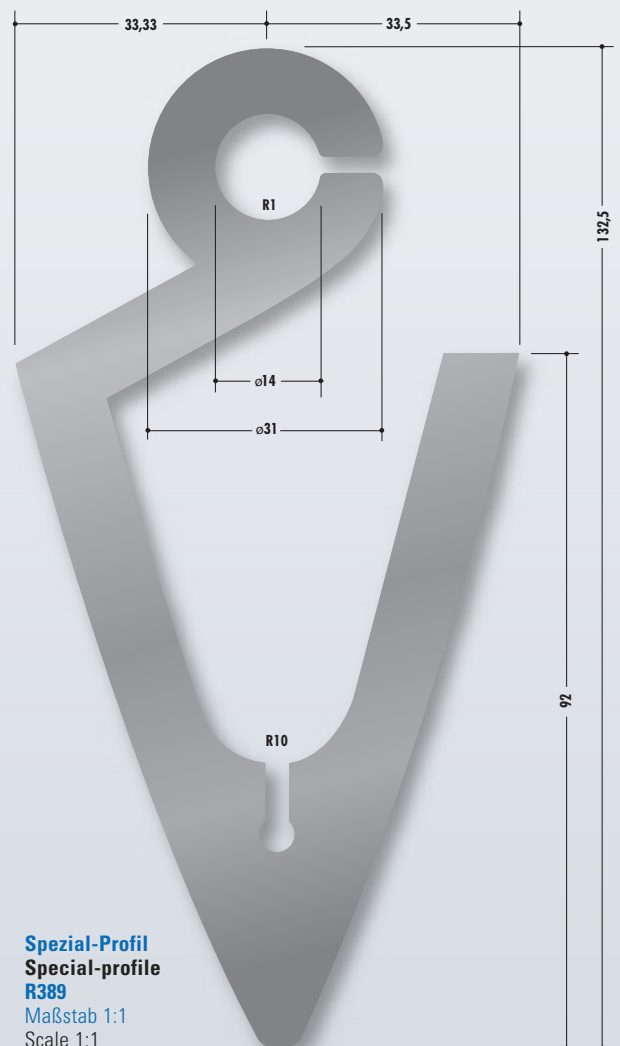

**Spezial-Profil
Special-profile
R389
Maßstab 1:1
Scale 1:1**

Verarbeitungskompetenz / Competence in machining

Weiterverarbeitung und Service

Finishing and service

Weiterverarbeitung und Service

Unsere Weiterverarbeitungsmöglichkeiten und unser Service runden das umfangreiche Angebot an extrudierten Profilen ab:

- Stanzen von Befestigungslöchern und Profildkonturen
- Einbringen von Bohrungen und Einschraubbohrungen
- Kombination mit Stahlprofilen
- Spanende Endbearbeitung des extrudierten Profils
- Zuschnitt auf Länge
- Lieferung auf Rolle

Zerspante Profile

Für Prototypen oder Bedarfsmengen, für die die Erstellung eines Extrusionswerkzeuges nicht wirtschaftlich ist, können wir Profile auch durch spanabhebende Bearbeitung herstellen. Hierfür setzt Röchling moderne Profilfräsmaschinen ein, mit denen auch anspruchsvolle Querschnitte hergestellt werden können. Als Hersteller von Kunststoffhalbzeugen verfügen wir über die notwendigen hochwertigen Materialien.

Finishing and service

The comprehensive range of extruded profiles is rounded off by finishing options and our package of services:

- Punching fixing holes and profile end contours
- Insertion of screw and plain holes
- Combination with steel profiles
- Final machining of the extruded profile
- Cutting to length
- Supplied as a roll

Machined profiles

For prototypes or quantities for which the manufacture of an extrusion tool is not economically viable, we can also produce profiles through machining processes. To do so Röchling uses modern profile milling machines that allow even complex cross-sections to be produced. As a manufacturer of semi-finished plastic products, we have the high-grade materials required.

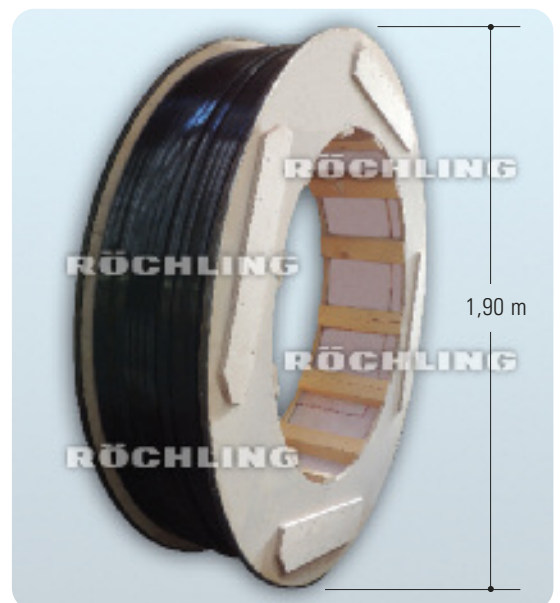
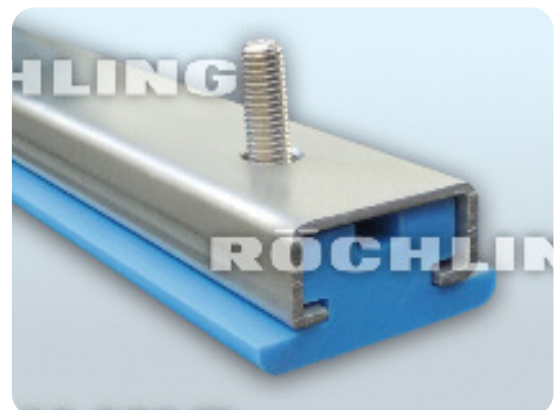
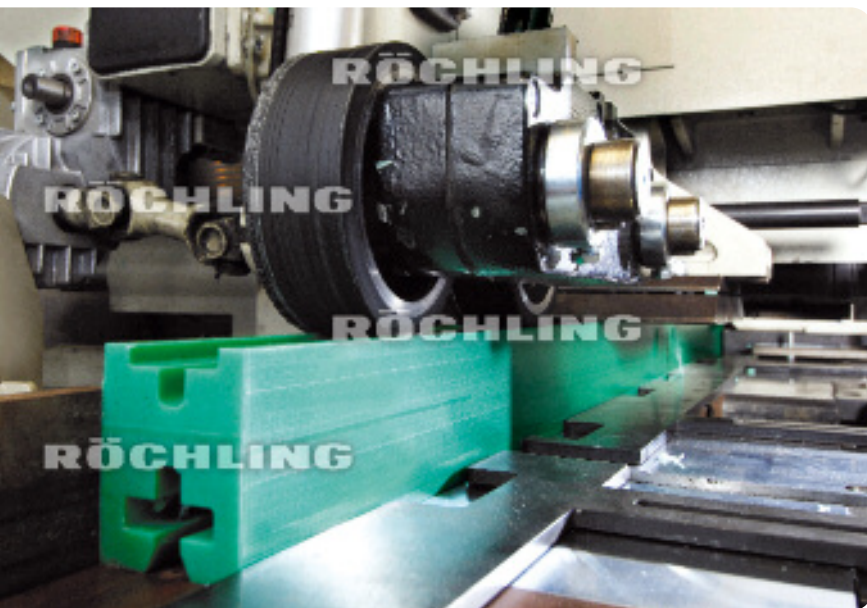

Wettbewerbsvorteil durch Innovation
Competitive advantages through innovation
Forschung und Entwicklung
Research and development

- Mehrwert für unsere Kunden**
- Produkt- und Werkstoffentwicklung
 - Modifikation bestehender Rezepturen
 - Praxisnahe Versuchsanlagen
 - Zusammenarbeit mit Wissenschaftlern
 - Moderne Werkstofflabors
- More value for our customers**
- Product and materials development
 - Modification of existing compositions
 - Practical testing facilities
 - Cooperation with scientists
 - State-of-the-art materials laboratory



Wettbewerbsvorteile durch Innovation

Das Thema Innovation hat bei Röchling höchste Priorität. So präsentieren wir dem Markt Produktentwicklungen, die unseren Kunden Wettbewerbsvorteile bieten.

In unseren gut ausgestatteten Werkstofflabors und in enger Kooperation mit Lieferanten, Wissenschaftlern und Instituten entwickeln wir zu den Aufgabenstellungen unserer Kunden neue Produkte und Herstellungsverfahren.

Das Qualitätsmanagementsystem unserer Unternehmen nach DIN EN ISO 9001:2008 ff. wird regelmäßig in Audits überprüft und dessen Einhaltung sichergestellt. Außerdem unterziehen wir unsere Produkte in allen Phasen des Produktionsprozesses permanenten Kontrollen.

Durch die Mitarbeit in zahlreichen Gremien und Ausschüssen stellen wir uns aktiv in den Dienst der Branchen und definieren so die Qualitätsstandards der Zukunft.

Competitive advantages through innovation

At Röchling, our top priority is innovation. This allows us to present the market with product developments that provide our customers with competitive advantages.

We develop new products and manufacturing processes to fit the specific problem definitions of our customers in our excellently outfitted materials laboratory, and in close cooperation with suppliers, scientists and institutes.

Our quality management system is regularly inspected in audits in accordance with DIN EN ISO 9001:2008 ff. and its compliance ensured. Moreover, our products undergo ongoing controls in all phases of the production process.

We actively engage in serving the industries through our collaboration with numerous advisory boards and committees, and thus, help define the quality standards of the future.



Branchenkompetenz / Competence in industry

Kundenanwendungen verstehen

Understanding customer applications



Spiralfroster mit extrudierten Profilen aus LubX®
Spiral froster with extruded profiles made of LubX®



Kurvenführung, LubX® C
Slide guide, LubX® C



Extrudiertes Profil als Handlauf einer Eishockey-Bande
Extruded profile as handrail on an ice hockey board



Spezialprofil für eine Getränkeabfüllanlage
Special profile for a drinks bottling plant



Kettenführungsprofil
Chain guide profile



Schlitten mit Kufen
aus extrudierten Profilen
Carriage with runners made
from extruded profiles



Energieeffizienz verbessern

Bei langfristig steigenden Energiepreisen spielt die **Senkung der Energiekosten** in Produktions-, Lager- und Logistikprozessen eine immer bedeutendere Rolle. Der Einsatz gleitoptimierter Komponenten in einem Förderprozess kann die **benötigte Förderkraft** – und somit die eingesetzte Energie – auf ein Minimum verringern. Die Leistungsfähigkeit und Effizienz der Anlage kann so deutlich verbessert werden.

Gleitreibungskoeffizient reduziert

Speziell für Anwendungen in der Förder- und Automatisierungstechnik hat Röchling mit **LubX® C** und **LubX® S** zwei neue, PE-1000-basierte Hochleistungswerkstoffe entwickelt, die über herausragende Trockenlaufefigenschaften verfügen. Der Gleitreibungskoeffizient konnte **um bis zu 75 Prozent reduziert** werden. Im Vergleich zu herkömmlichen Gleitwerkstoffen benötigen mit LubX® ausgestattete Fördersysteme deutlich weniger Energie, die Prozessstabilität wird erhöht und der Geräuschpegel erheblich verringert.

Tribologische Systeme

Bei der Entwicklung der LubX®-Produkte wurde nicht nur darauf geachtet, den Gleitreibungskoeffizienten der Gleitwerkstoffe zu minimieren, sondern das tribologische System der Gleitpartner ganzheitlich zu betrachten und auf die jeweiligen, speziellen Anforderungen hin abzustimmen. Deshalb wurden die einzelnen Bewegungs- und Transportabschnitte von verschiedenen Fördersystemen analysiert und die Relativbewegungen der Elemente und die an den Berührungspunkten entstehenden Reibungskräfte untersucht. Diese Kräfte haben maßgeblichen Einfluss auf die Leistungsfähigkeit des Fördersystems.

Improve energy efficiency

With energy prices rising in the long term, **lowering energy costs** plays an increasingly more important role in the project planning of production, storage and logistic processes. When utilising components with optimized sliding properties in conveying processes, the **conveying power required** – and thus the energy applied – may be reduced to a minimum. The performance and efficiency of the plant can thus be considerably enhanced.

Reduced coefficient of friction

In **LubX® C** and **LubX® S**, Röchling has developed two new, PE-1000-based high-performance materials with outstanding dry running properties especially for use in materials-handling technology and automation. The slide friction coefficient has been **reduced by as much as 75 per cent**. When compared to conventional slide materials, conveyor systems equipped with LubX® require significantly less energy, process stability is increased and the noise level is considerably reduced.

Tribological systems

In the development of LubX® products, great care has not only been taken to minimise the coefficient of friction of the sliding materials, but also to consider the tribological system of the sliding partners in an integrated manner and especially aligned to the particular specific requirements concerned. The individual motion and transport segments of different conveying systems were analysed, and the relative movements of the elements and the frictional forces arising at the points of contact examined. These frictional forces have a decisive impact on the performance of the conveying system.

Gleiteigenschaften im Vergleich Comparison of sliding properties

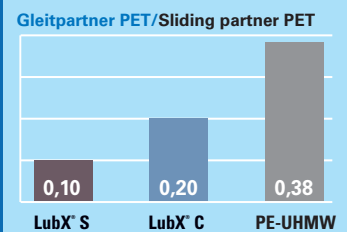
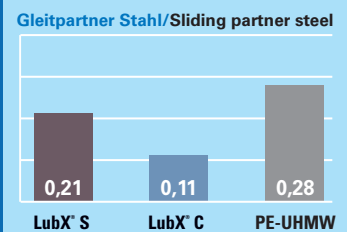
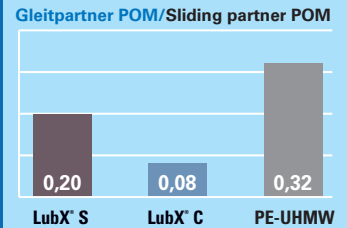

Gleitreibungskoeffizienten unter Trockenbedingungen / Auf anwendungsnahem Röchling-Tribologieprüfstand validiert
Geschwindigkeit: 0,25 m/s
Flächenpressung: 0,25 MPa
Prüfzeit: 24 h

Coefficients of sliding friction under dry conditions / Validated on the application-related Röchling tribology test stand
Speed: 0.25 m/s
Surface pressure: 0.25 MPa
Test time: 24 h



Fördersystem mit Gleitelementen aus LubX® S und LubX® C
Conveyor system with sliding parts from LubX® S and LubX® C

Z-Profile

Z-profiles

Standardlänge: 6000 mm oder Rollenware
 Qualitäten: M-natur, M-schwarz, M-grün (PE-UHMW/PE 1000)
 Standard length: 6000 mm or in coils
 Qualities: M-natural, M-black, M-green (PE-UHMW/PE 1000)

Rollenlänge ca. 60 m
 Length per roll ca. 60 m

● ab Lager lieferbar / available ex stock

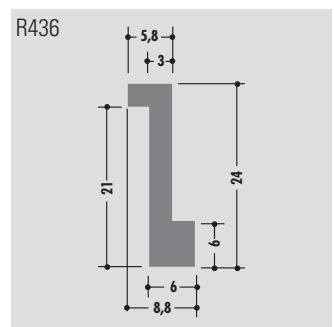
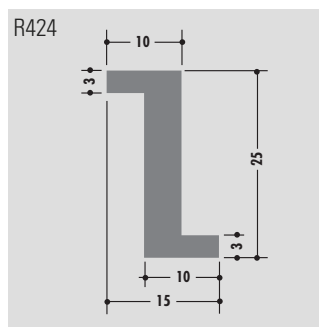
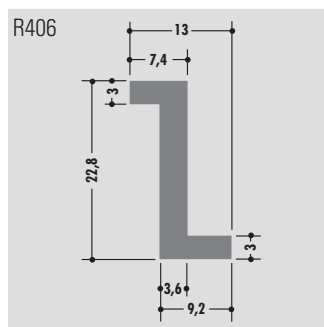
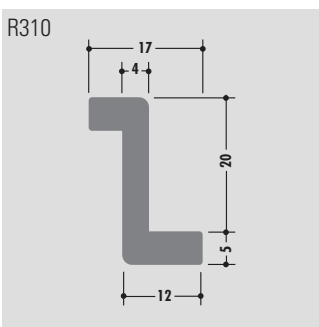
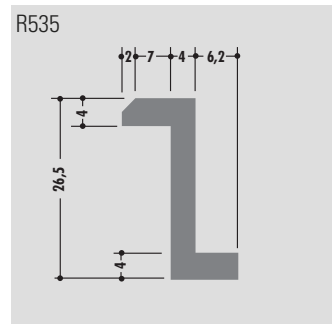
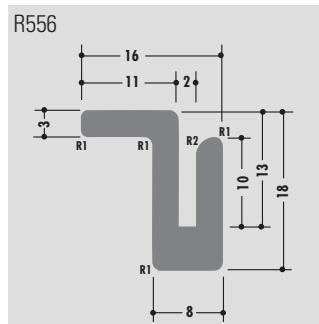
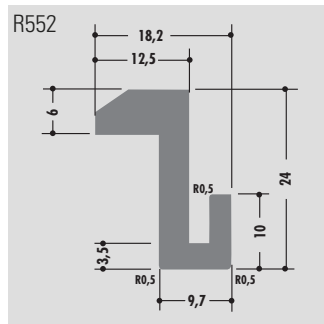
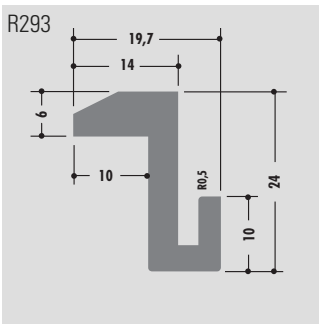
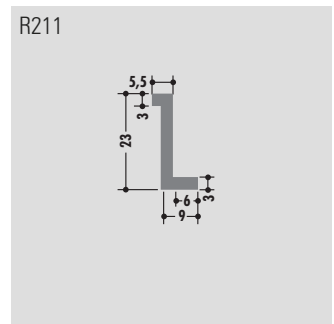
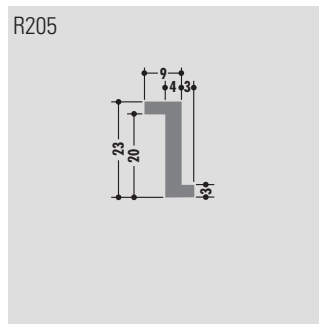
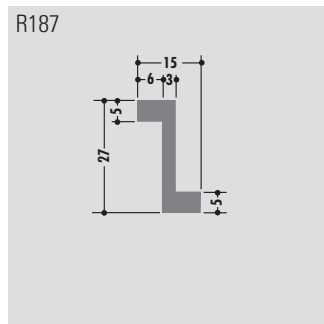
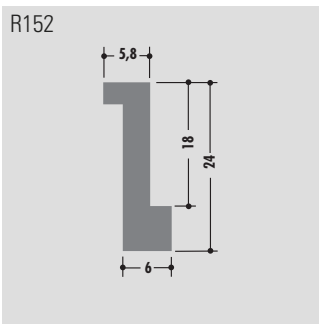
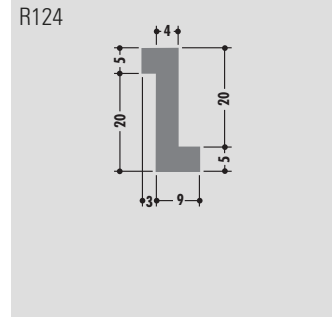
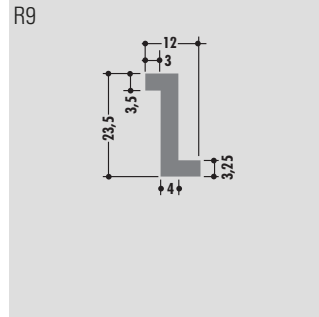
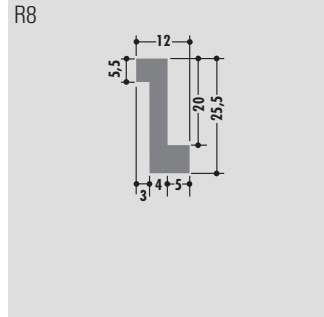
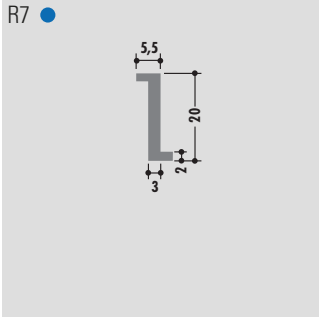

L-Profile L-profiles

Standardlänge: 6000 mm oder Rollenware
 Qualitäten: M-natur, M-schwarz, M-grün (PE-UHMW/PE 1000)
 Standard length: 6000 mm or in coils
 Qualities: M-natural, M-black, M-green (PE-UHMW/PE 1000)

Rollenlänge ca. 60 m
 Length per roll ca. 60 m

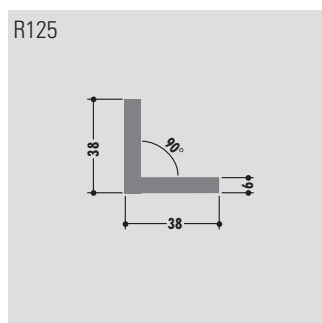
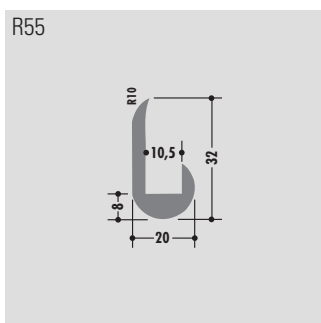
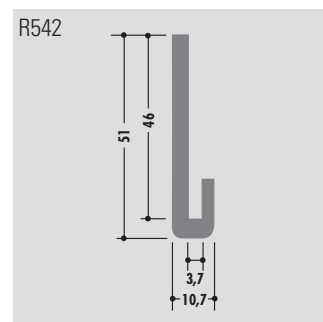
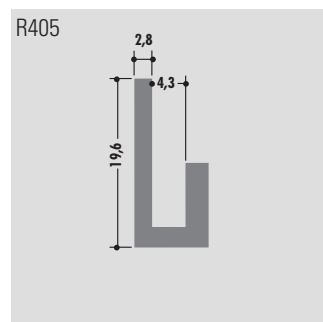
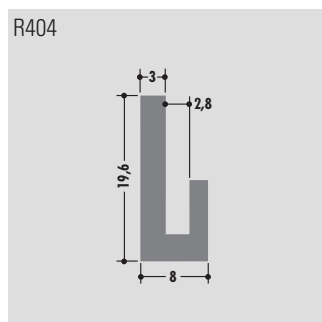
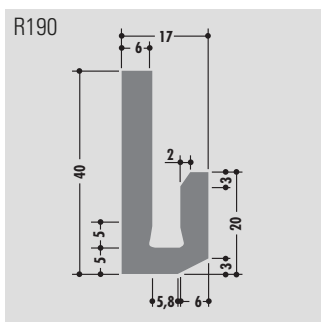
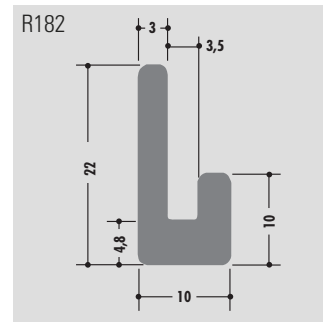
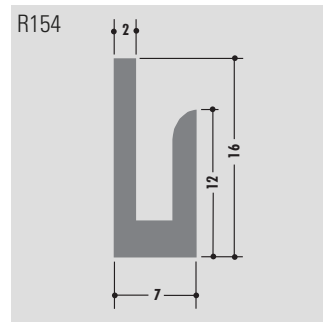
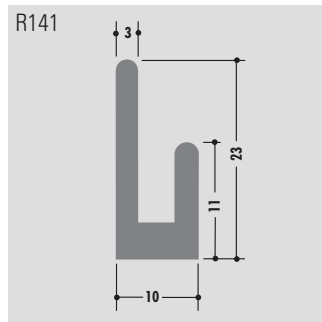
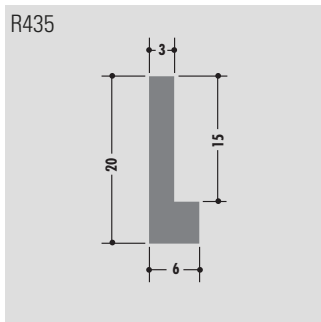
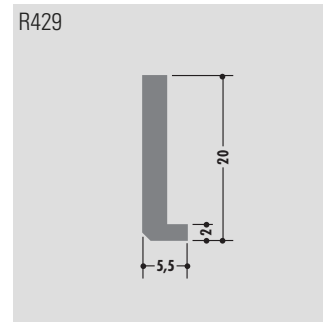
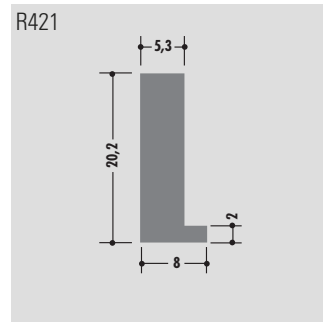
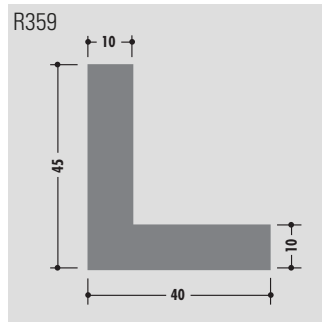
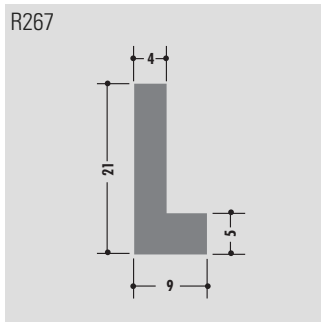
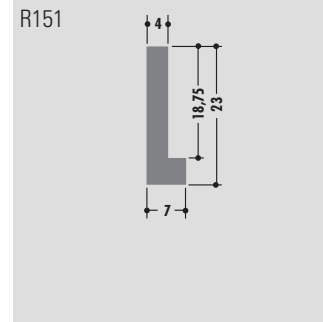
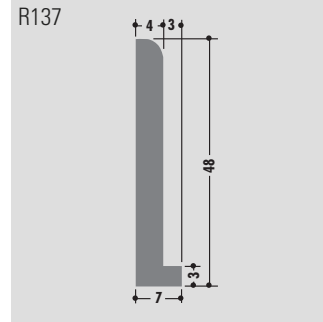
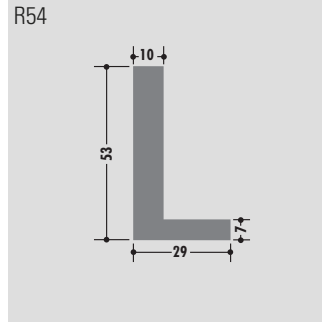
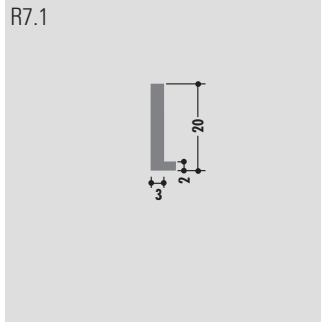

Z-Profile Z-profiles
L-Profile L-profiles
Klemmprofile Clamp-profiles
T-Profile T-profiles
U-Profile U-profiles
C-Profile C-profiles
Halbrund-Profile Round bar cover
Rohre Tubes
Seitenführungsprofile Side guide profile
Vierkantprofile Square-profiles
Clip-Profile Clip-profiles
Spezial-Profile Special-profiles
Bandmaterial Wear strips
Folien Film

Klemmprofile Clamp-profiles

Standardlänge: 6000 mm oder Rollenware
 Qualitäten: M-natur, M-schwarz, M-grün (PE-UHMW/PE 1000)
 Standard length: 6000 mm or in coils
 Qualities: M-natural, M-black, M-green (PE-UHMW/PE 1000)

Rollenlänge ca. 60 m
 Length per roll ca. 60 m

● ab Lager lieferbar / available ex stock

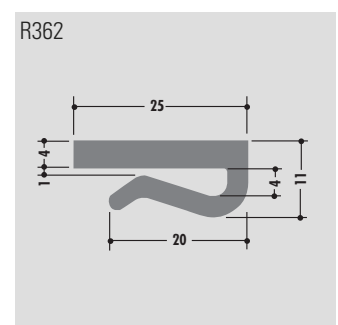
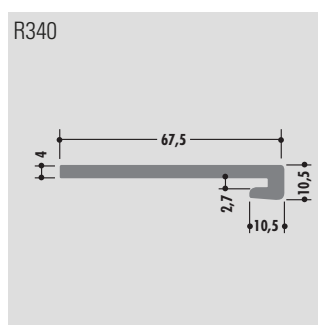
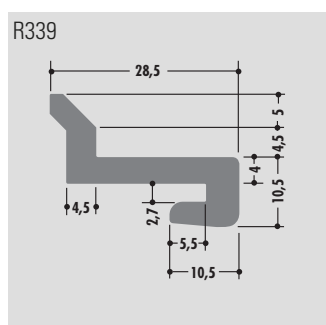
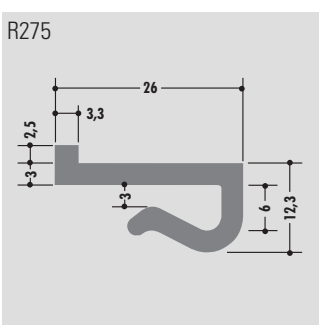
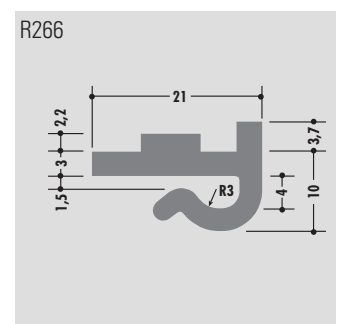
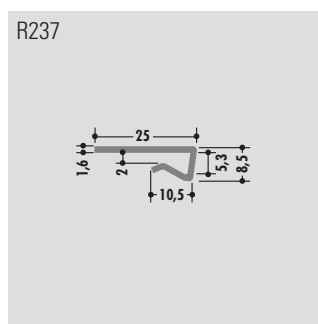
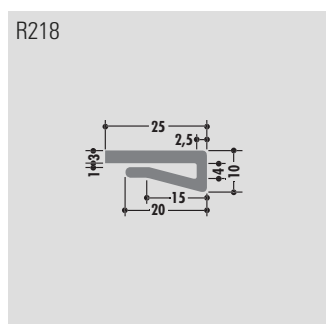
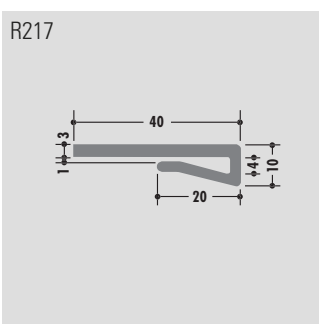
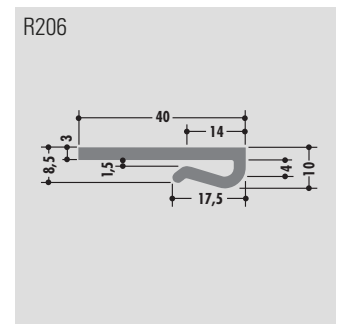
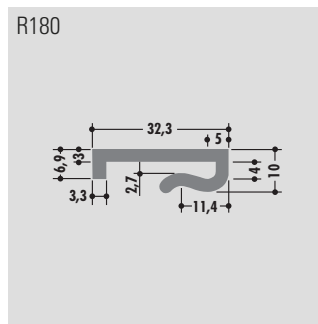
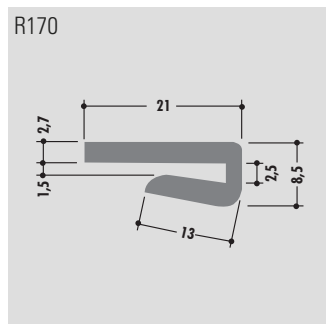
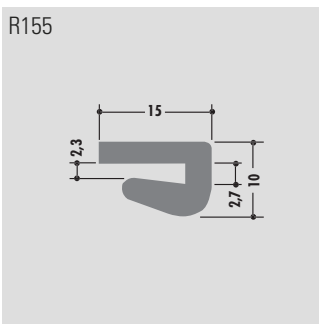
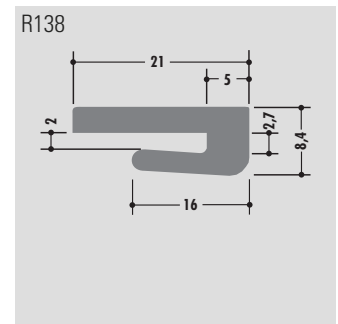
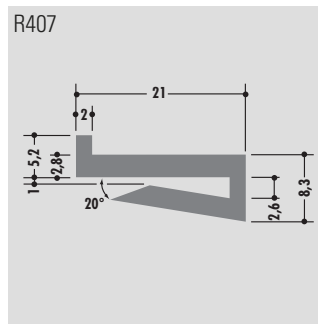
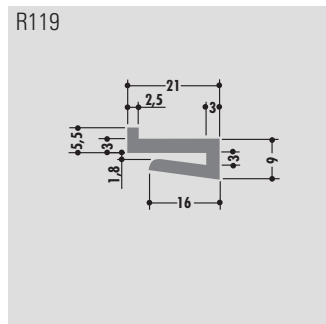
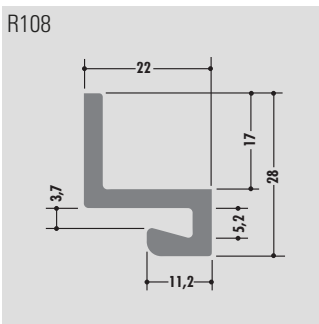
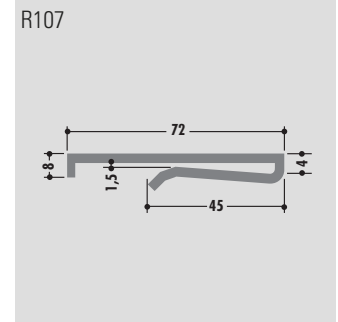
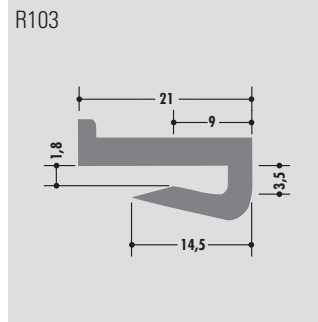
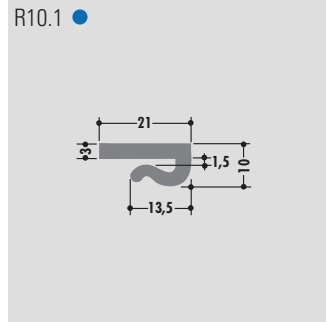
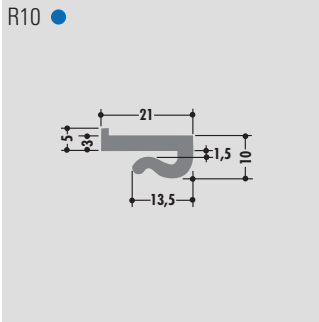

Klemmprofile Clamp-profiles

Standardlänge: 6000 mm oder Rollenware
 Qualitäten: M-natur, M-schwarz, M-grün (PE-UHMW/PE 1000)
 Standard length: 6000 mm or in coils
 Qualities: M-natural, M-black, M-green (PE-UHMW/PE 1000)

Rollenlänge ca. 60 m
 Length per roll ca. 60 m

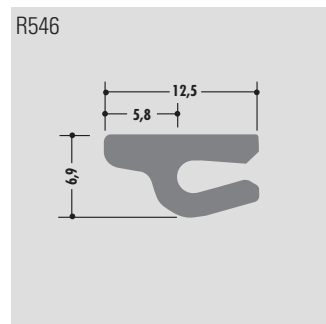
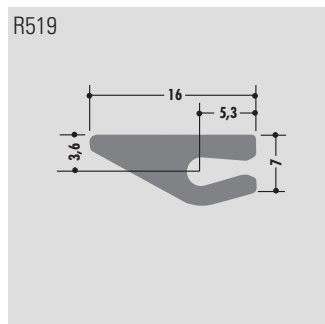
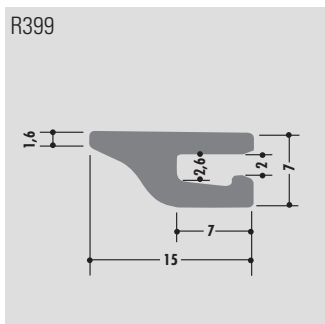
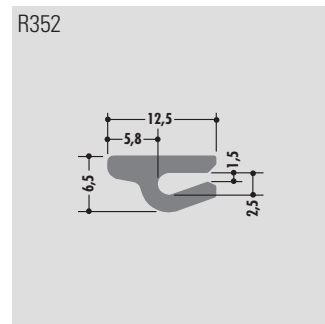
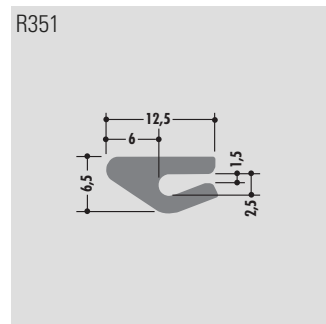
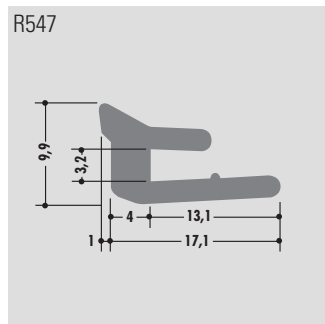
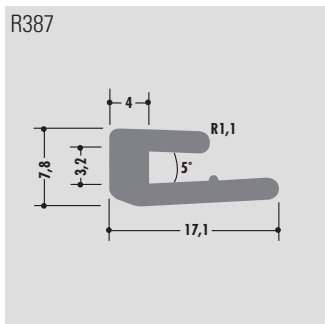
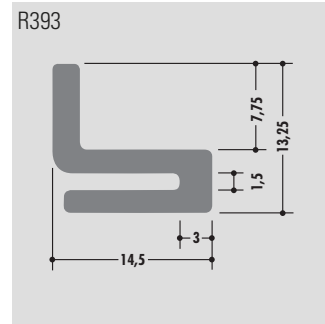
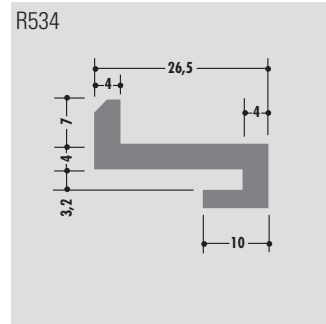
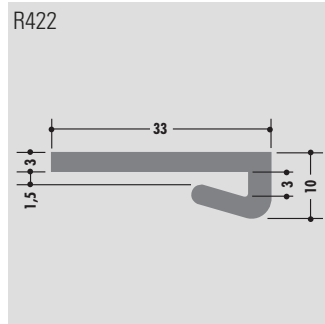
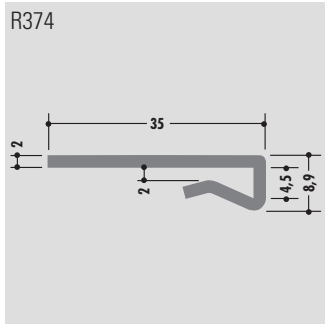

Z-Profile Z-profiles
L-Profile L-profiles
Klemmprofile Clamp-profiles
T-Profile T-profiles
U-Profile U-profiles
C-Profile C-profiles
Halbrund-Profile Round bar cover
Rohre Tubes
Seitenführungsprofile Side guide profile
Vierkantprofile Square-profiles
Clip-Profile Clip-profiles
Spezial-Profile Special-profiles
Bandmaterial Wear strips
Folien Film

T-Profile T-profiles

Standardlänge: 6000 mm oder Rollenware
 Qualitäten: M-natur, M-schwarz, M-grün (PE-UHMW/PE 1000)
 Standard length: 6000 mm or in coils
 Qualities: M-natural, M-black, M-green (PE-UHMW/PE 1000)

Rollenlänge ca. 60 m
 Length per roll ca. 60 m

● ab Lager lieferbar / available ex stock

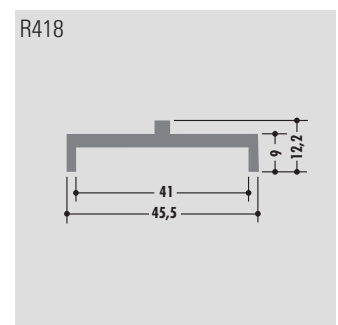
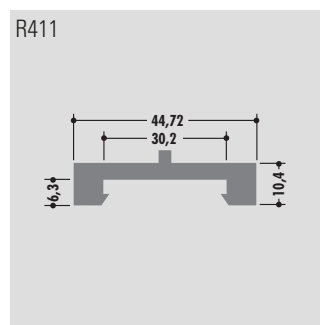
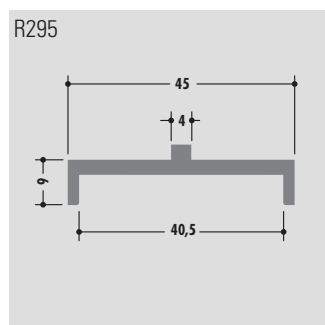
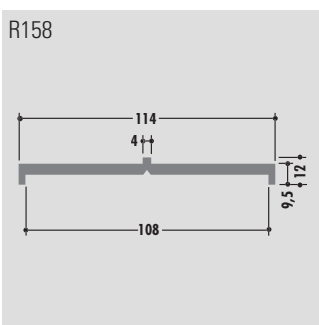
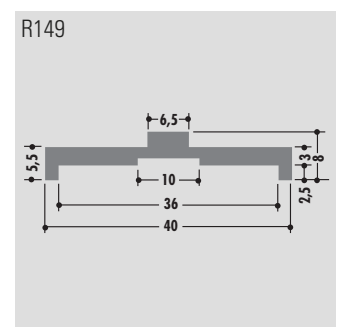
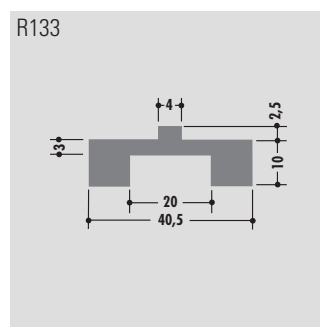
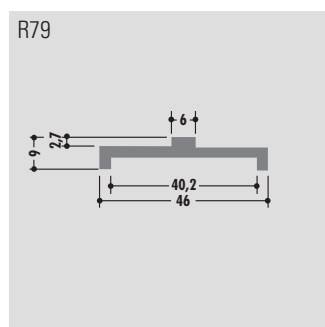
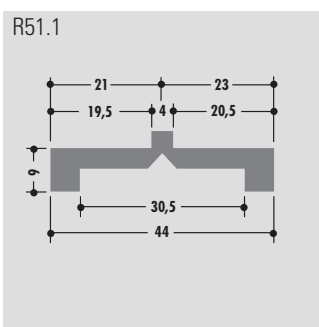
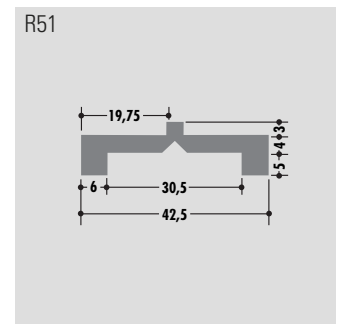
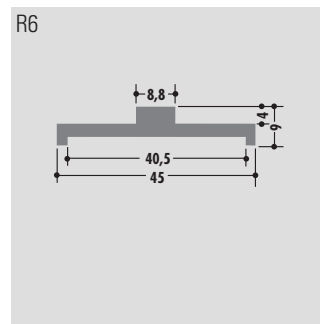
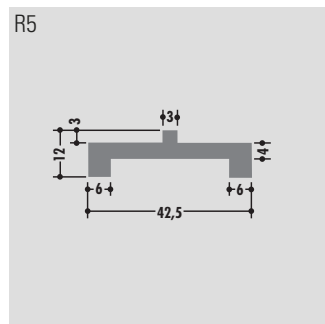
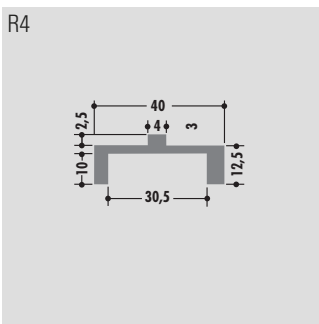
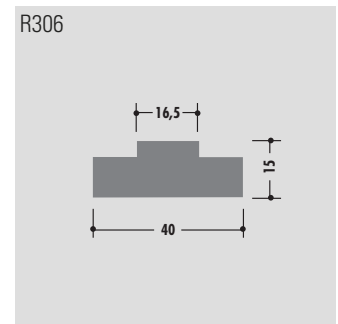
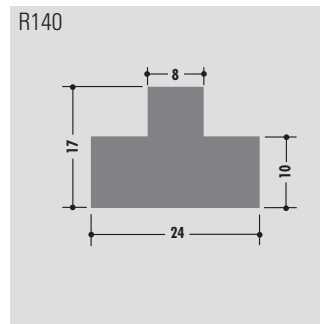
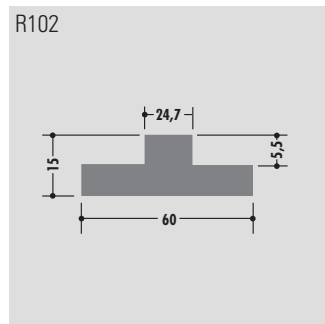
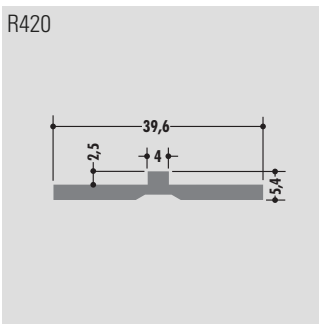
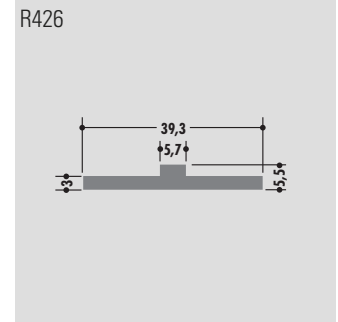
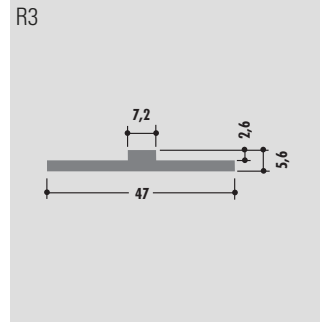
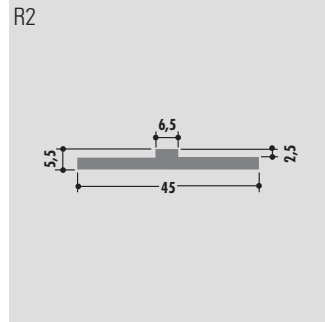
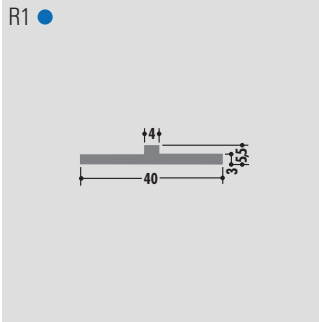

T-Profile T-profiles

Standardlänge: 6000 mm oder Rollenware
 Qualitäten: M-natur, M-schwarz, M-grün (PE-UHMW/PE 1000)
 Standard length: 6000 mm or in coils
 Qualities: M-natural, M-black, M-green (PE-UHMW/PE 1000)

Rollenlänge ca. 60 m
 Length per roll ca. 60 m

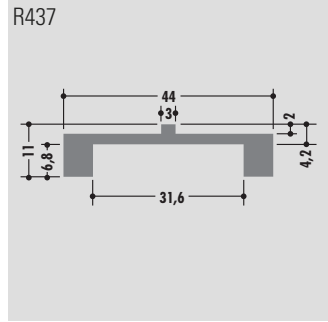
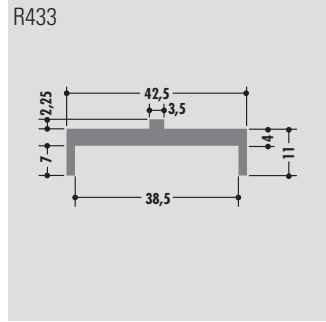
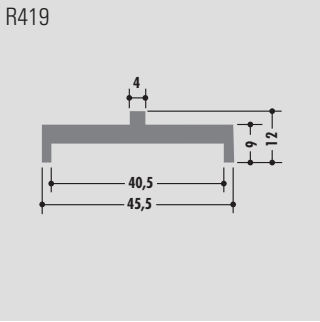

- Z-Profile
Z-profiles
- L-Profile
L-profiles
- Klemmprofile
Clamp-profiles
- T-Profile
T-profiles
- U-Profile
U-profiles
- C-Profile
C-profiles
- Halbrund-Profil
Round bar cover
- Rohre
Tubes
- Seitenführungsprofile
Side guide profile
- Vierkantprofile
Square-profiles
- Clip-Profile
Clip-profiles
- Spezial-Profile
Special-profiles
- Bandmaterial
Wear strips
- Folien
Film

U-Profile U-profiles

Standardlänge: 6000 mm oder Rollenware
 Qualitäten: M-natur, M-schwarz, M-grün (PE-UHMW/PE 1000)
 Standard length: 6000 mm or in coils
 Qualities: M-natural, M-black, M-green (PE-UHMW/PE 1000)

Rollenlänge ca. 60 m
 Length per roll ca. 60 m

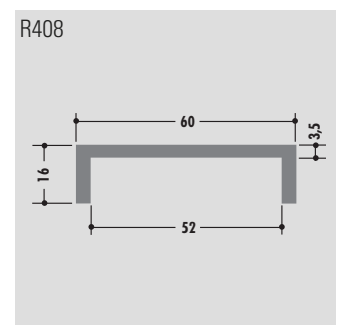
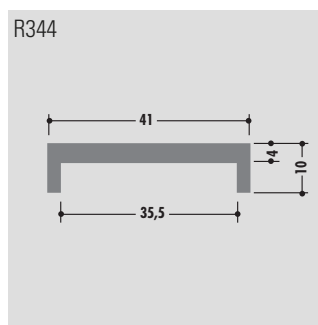
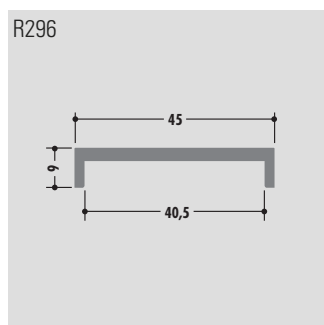
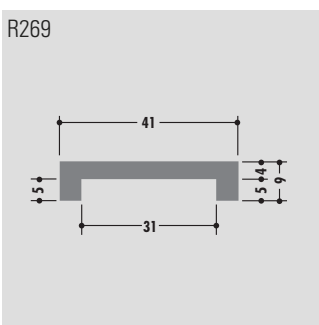
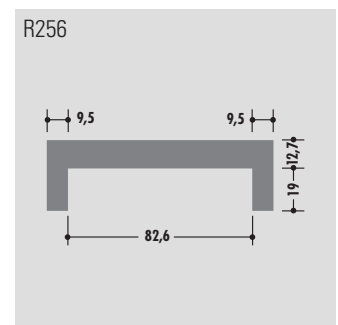
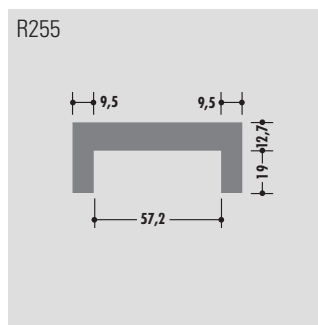
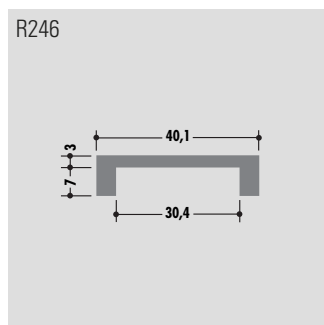
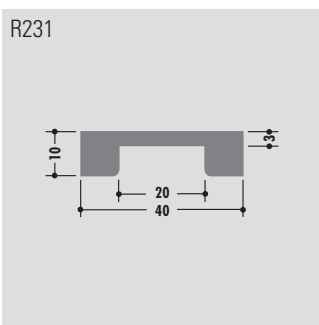
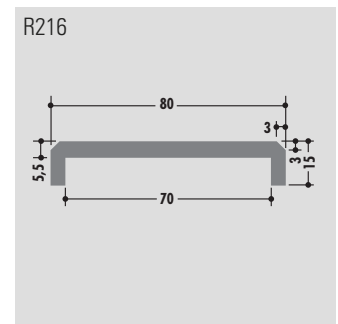
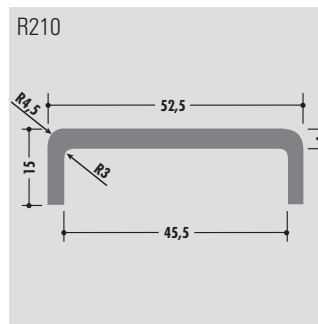
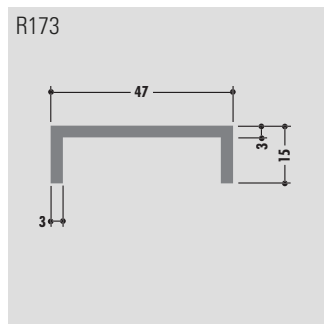
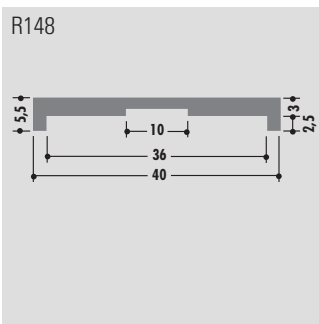
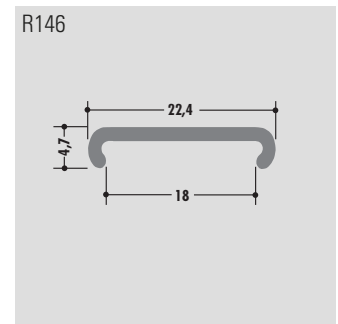
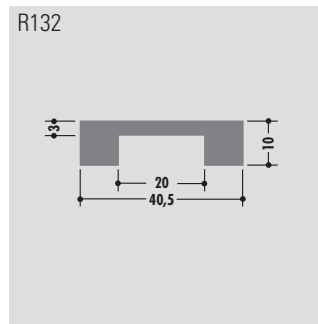
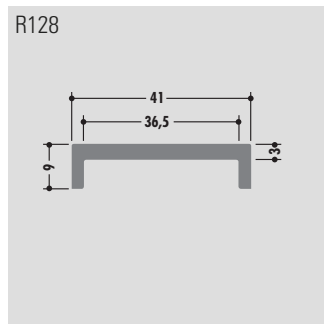
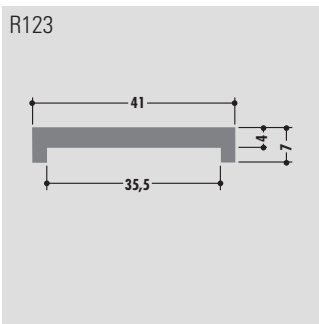
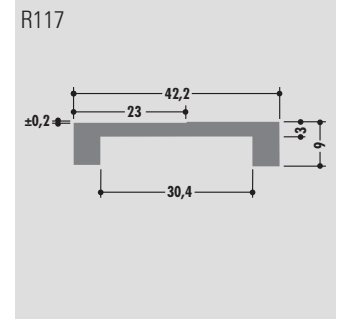
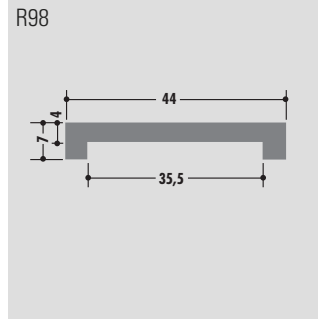
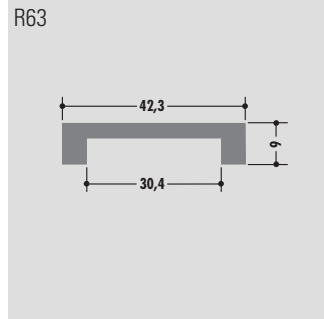
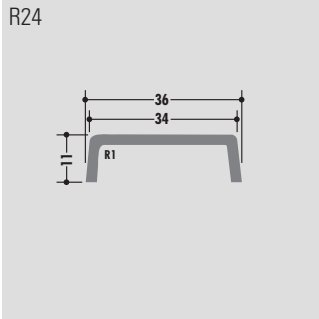

U-Profile U-profiles

Standardlänge: 6000 mm oder Rollenware
 Qualitäten: M-natur, M-schwarz, M-grün (PE-UHMW/PE 1000)
 Standard length: 6000 mm or in coils
 Qualities: M-natural, M-black, M-green (PE-UHMW/PE 1000)

Rollenlänge ca. 60 m
 Length per roll ca. 60 m

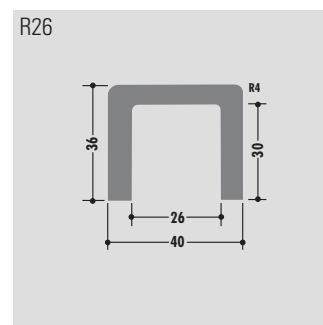
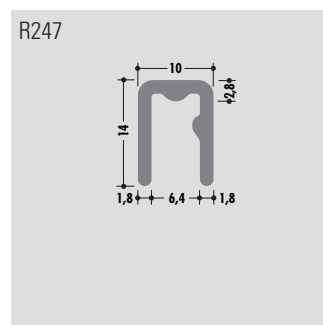
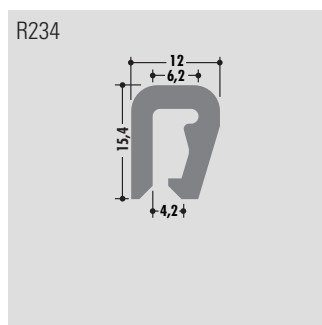
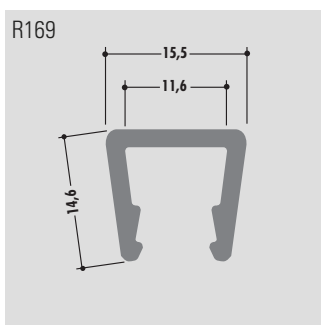
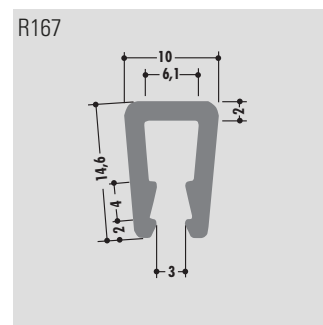
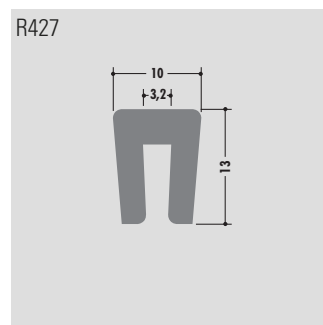
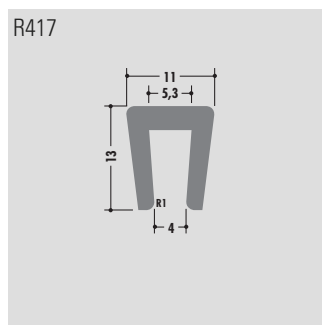
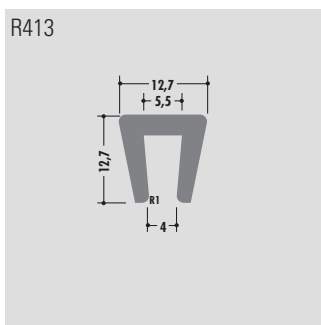
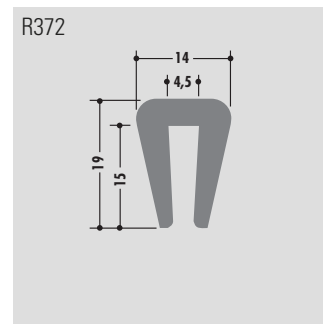
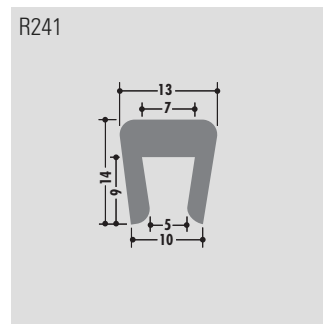
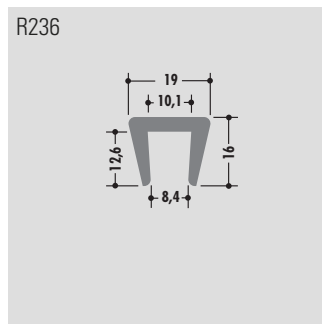
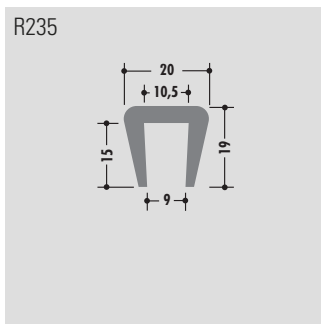
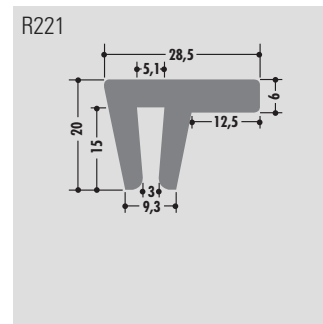
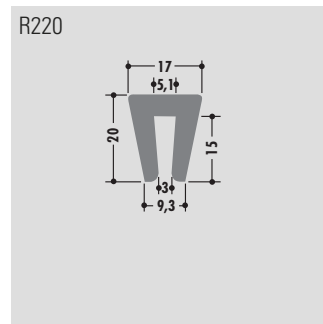
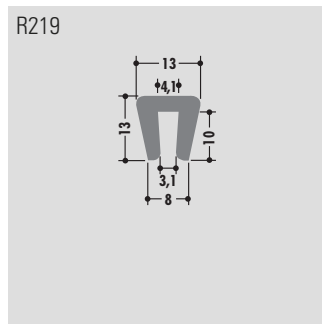
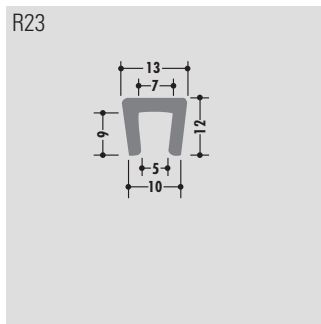
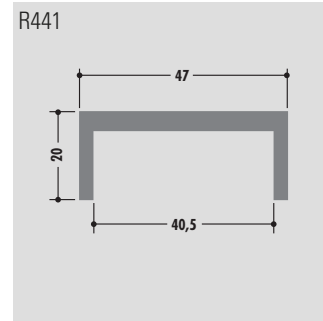
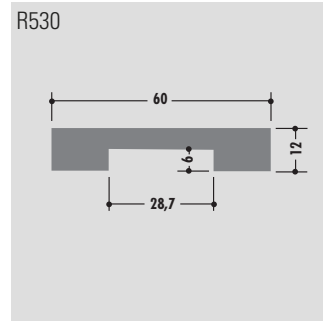
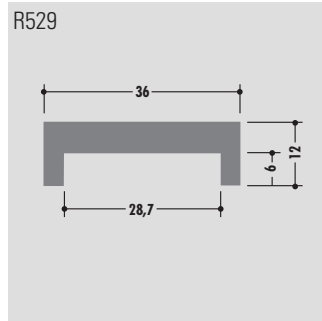
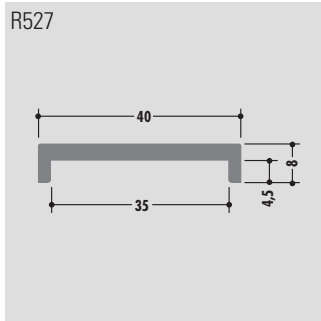

Z-Profile Z-profiles
L-Profile L-profiles
Klemmprofile Clamp-profiles
T-Profile T-profiles
U-Profile U-profiles
C-Profile C-profiles
Halbrund-Profile Round bar cover
Rohre Tubes
Seitenführungsprofile Side guide profile
Vierkantprofile Square-profiles
Clip-Profile Clip-profiles
Spezial-Profile Special-profiles
Bandmaterial Wear strips
Folien Film

U-Profile U-profiles

Standardlänge: 6000 mm oder Rollenware
 Qualitäten: M-natur, M-schwarz, M-grün (PE-UHMW/PE 1000)
 Standard length: 6000 mm or in coils
 Qualities: M-natural, M-black, M-green (PE-UHMW/PE 1000)

Rollenlänge ca. 60 m
 Length per roll ca. 60 m

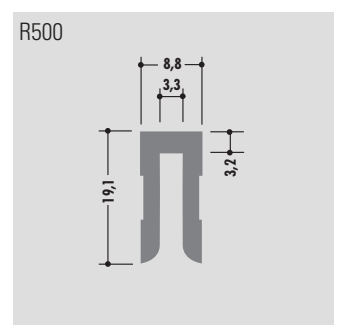
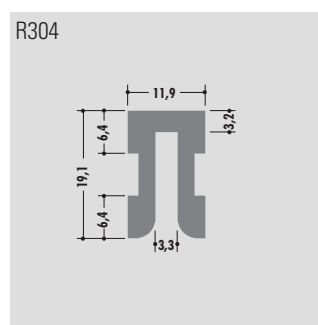
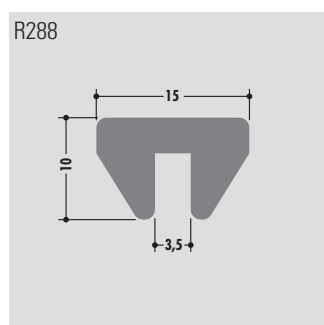
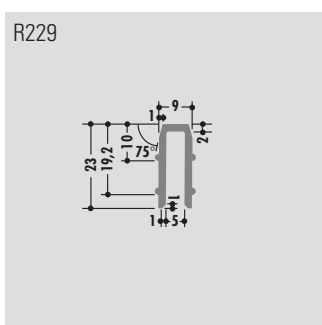
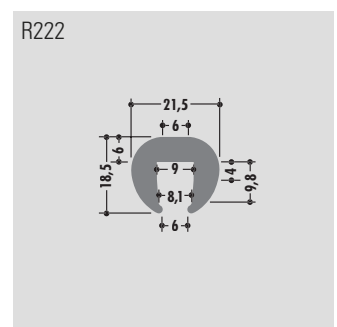
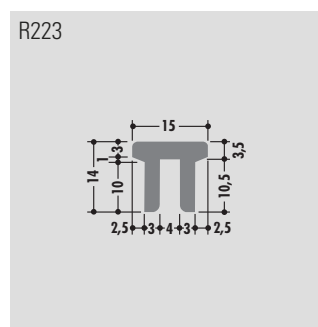
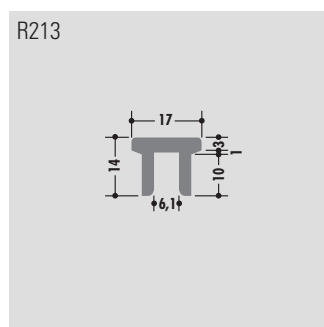
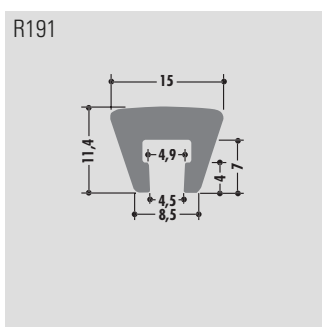
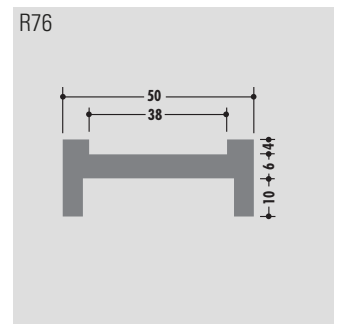
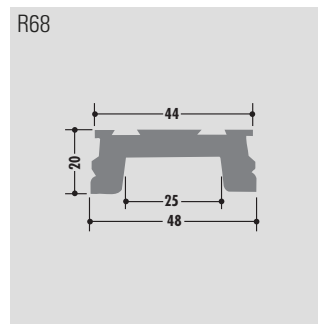
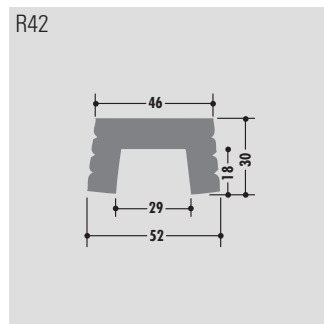
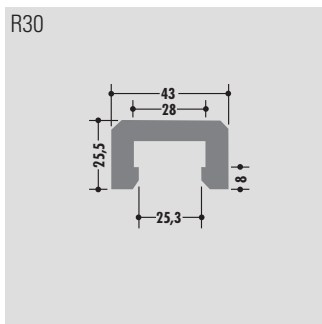
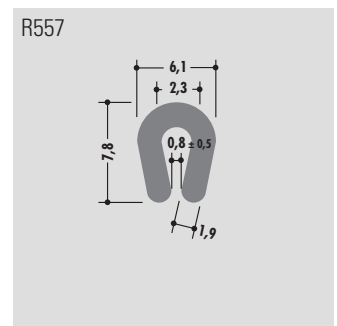
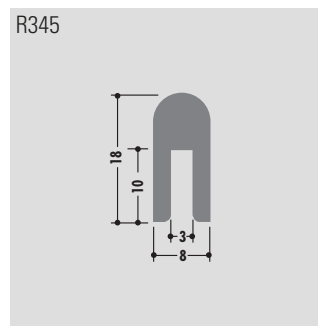
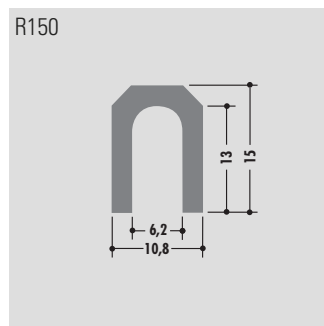
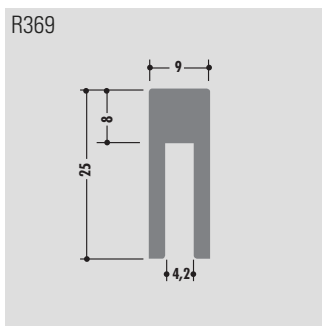
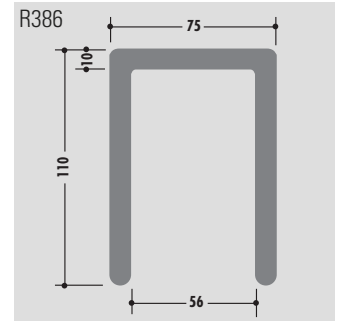
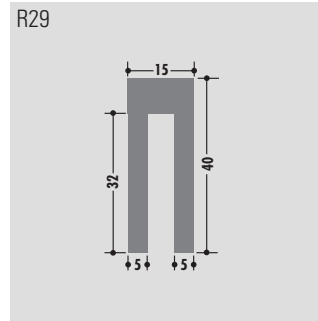
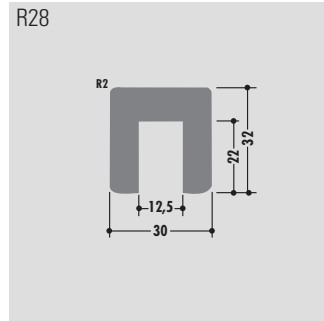
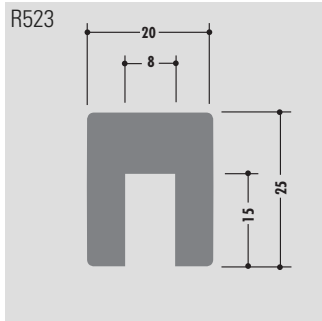

U-Profile U-profiles

Standardlänge: 6000 mm oder Rollenware
 Qualitäten: M-natur, M-schwarz, M-grün (PE-UHMW/PE 1000)
 Standard length: 6000 mm or in coils
 Qualities: M-natural, M-black, M-green (PE-UHMW/PE 1000)

Rollenlänge ca. 60 m
 Length per roll ca. 60 m

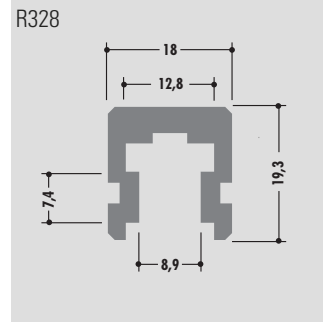
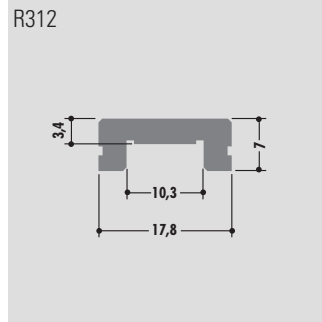
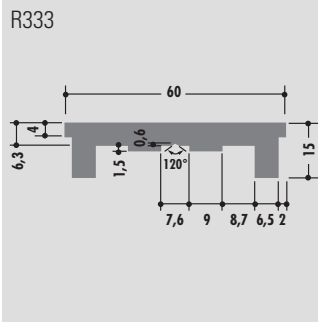

Z-Profile
Z-profiles

L-Profile
L-profiles

Klemmprofile
Clamp-profiles

T-Profile
T-profiles

U-Profile
U-profiles

C-Profile
C-profiles

Halbrund-Profil
Round bar cover

Rohre
Tubes

Seitenführungsprofil
Side guide profile

Vierkantprofil
Square-profiles

Clip-Profile
Clip-profiles

Spezial-Profile
Special-profiles

Bandmaterial
Wear strips

Folien
Film

C-Profile C-profiles

Standardlänge: 6000 mm oder Rollenware
 Qualitäten: M-natur, M-schwarz, M-grün (PE-UHMW/PE 1000)
 Standard length: 6000 mm or in coils
 Qualities: M-natural, M-black, M-green (PE-UHMW/PE 1000)

Rollenlänge ca. 60 m
 Length per roll ca. 60 m

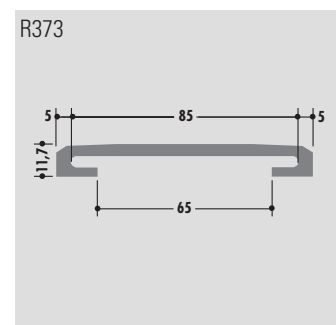
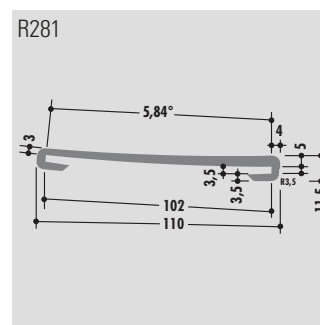
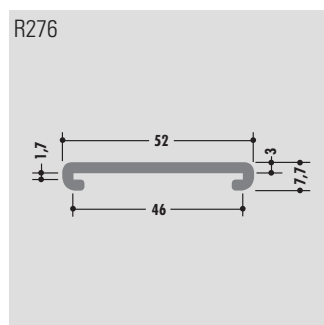
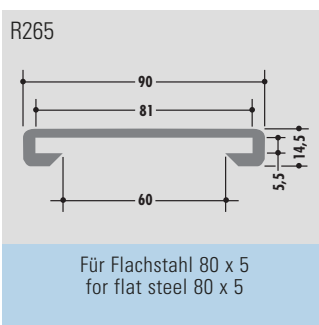
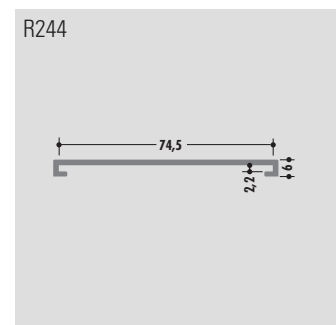
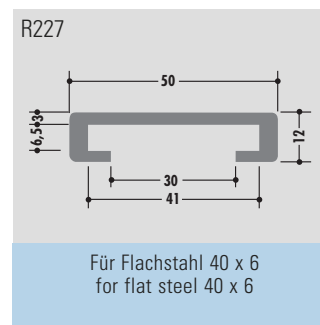
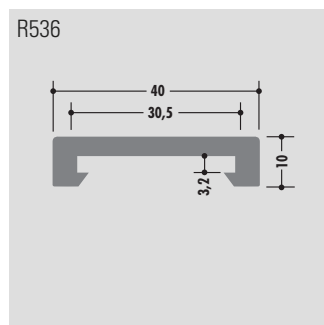
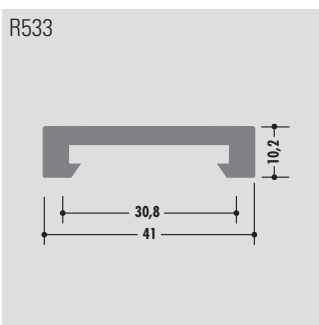
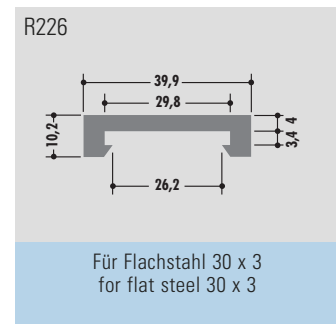
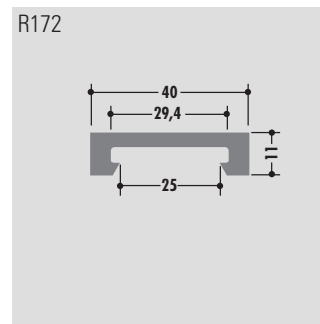
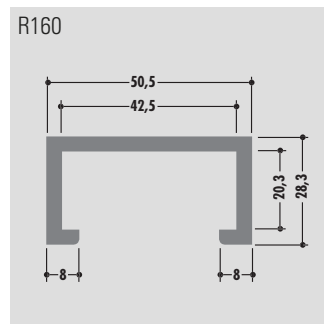
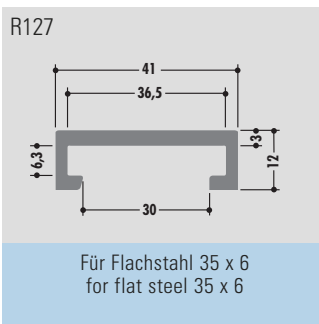
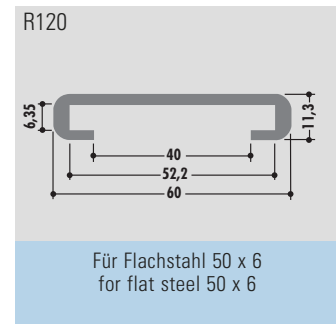
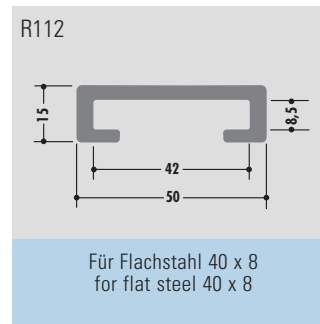
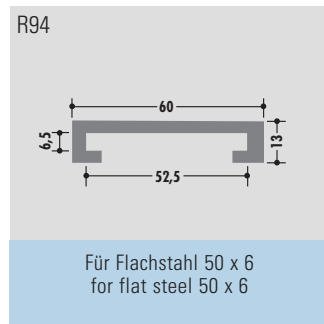
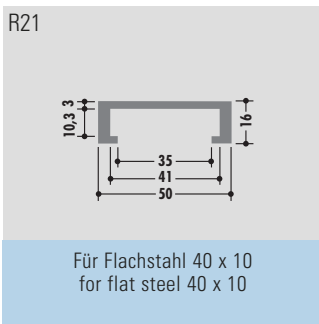
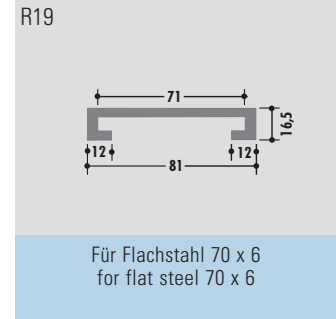
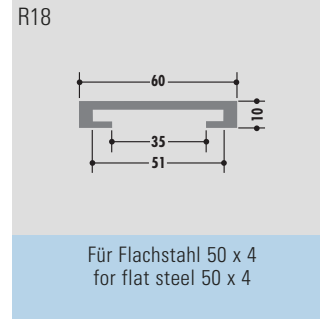
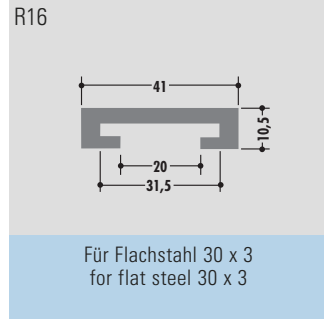
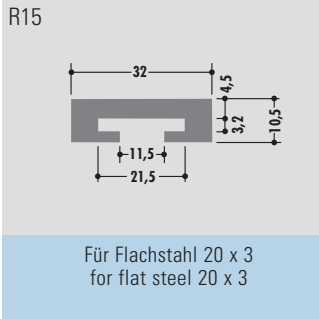

C-Profile C-profiles

Standardlänge: 6000 mm oder Rollenware
 Qualitäten: M-natur, M-schwarz, M-grün (PE-UHMW/PE 1000)
 Standard length: 6000 mm or in coils
 Qualities: M-natural, M-black, M-green (PE-UHMW/PE 1000)

Rollenlänge ca. 60 m
 Length per roll ca. 60 m

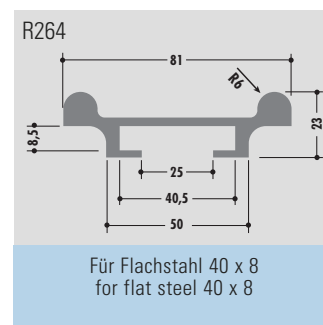
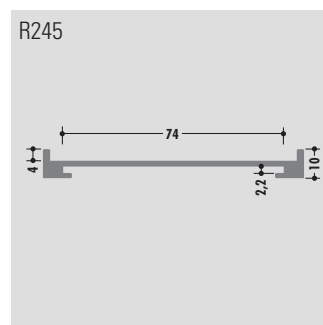
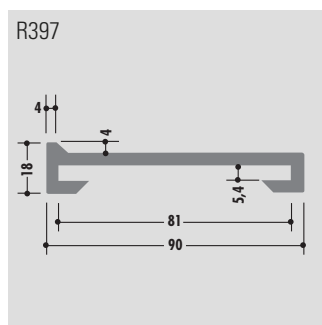
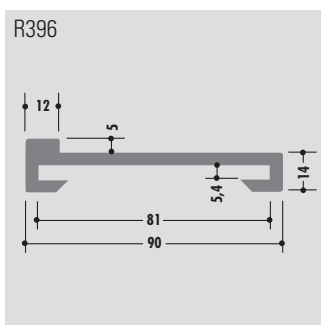
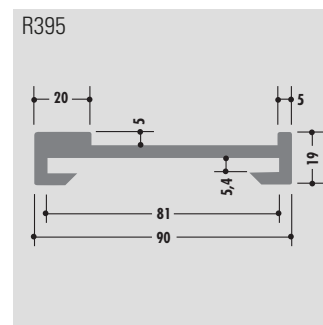
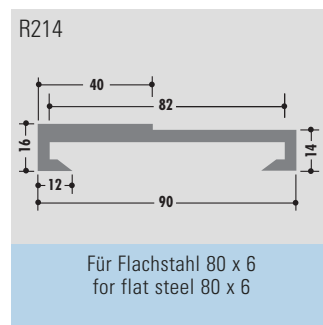
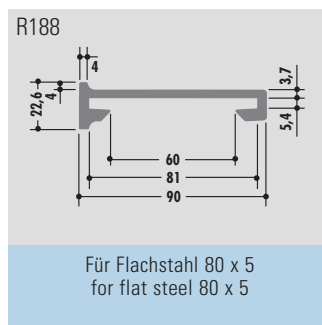
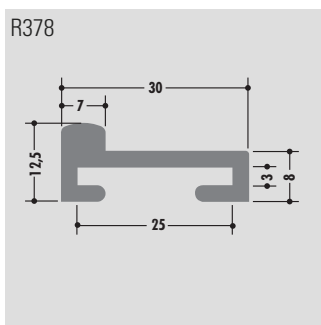
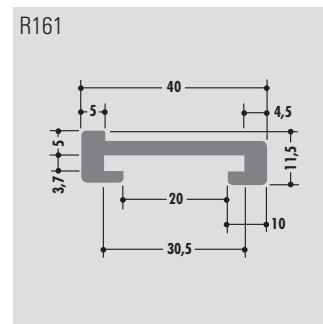
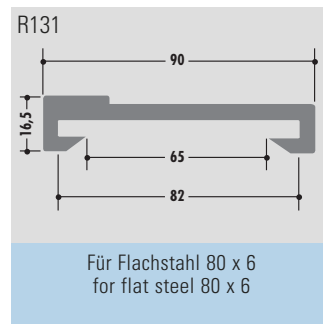
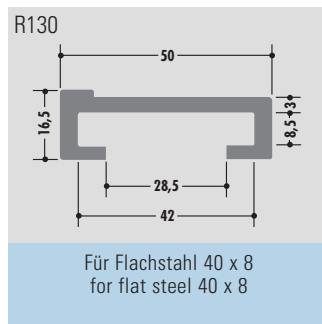
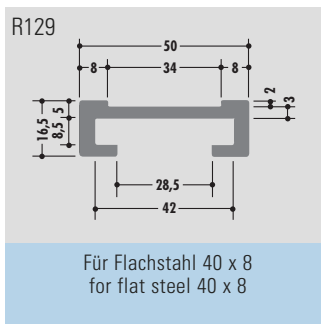
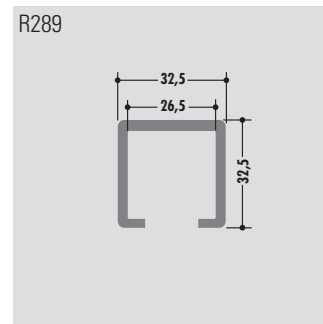
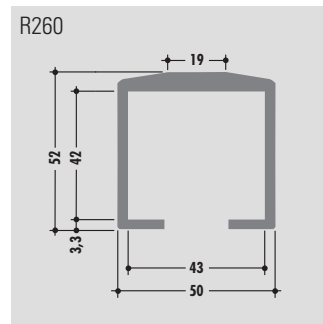
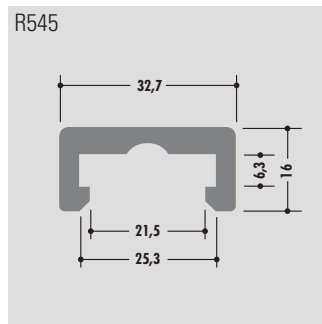
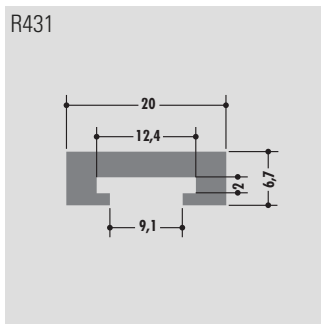
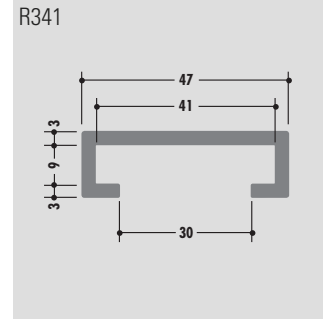
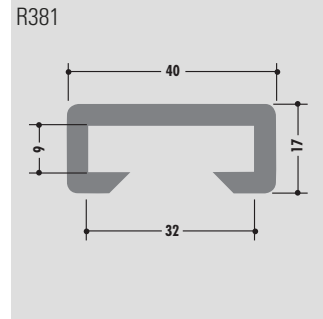
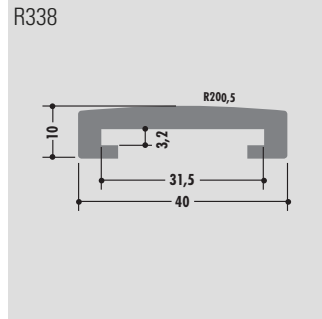
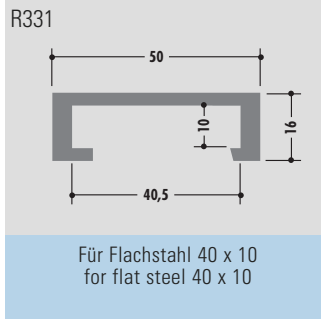

Z-Profile Z-profiles
L-Profile L-profiles
Klemmprofile Clamp-profiles
T-Profile T-profiles
U-Profile U-profiles
C-Profile C-profiles
Halbrund-Profile Round bar cover
Rohre Tubes
Seitenführungsprofile Side guide profile
Vierkantprofile Square-profiles
Clip-Profile Clip-profiles
Spezial-Profile Special-profiles
Bandmaterial Wear strips
Folien Film

C-Profile

C-profiles

Standardlänge: 6000 mm oder Rollenware
 Qualitäten: M-natur, M-schwarz, M-grün (PE-UHMW/PE 1000)
 Standard length: 6000 mm or in coils
 Qualities: M-natural, M-black, M-green (PE-UHMW/PE 1000)

Rollenlänge ca. 60 m
 Length per roll ca. 60 m

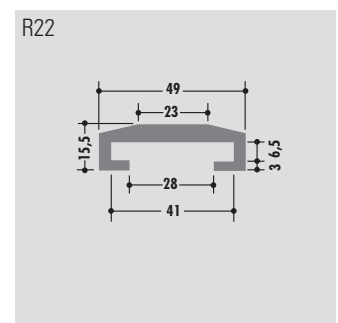
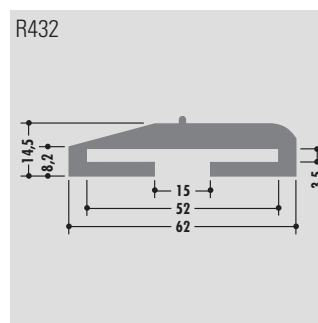
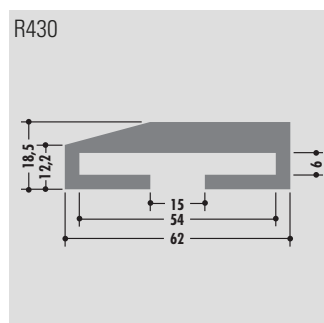
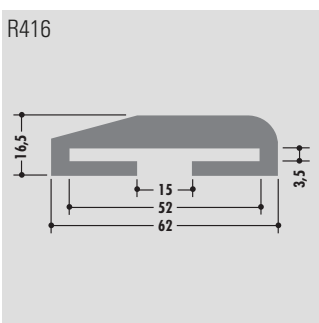
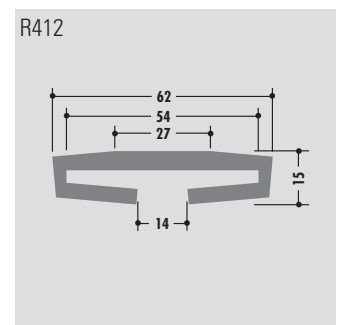
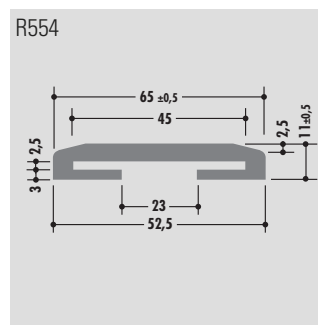
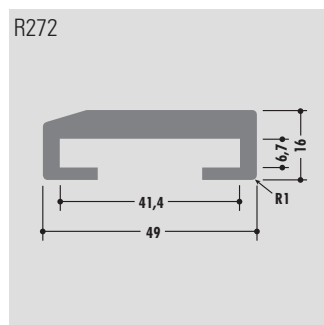
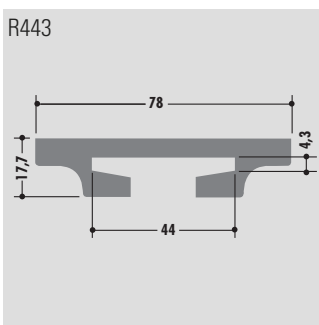
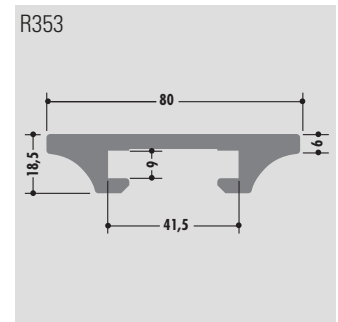
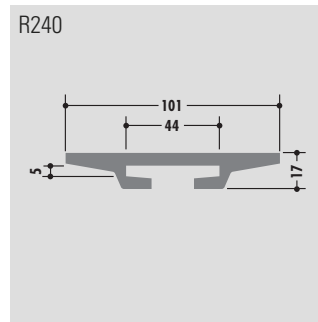
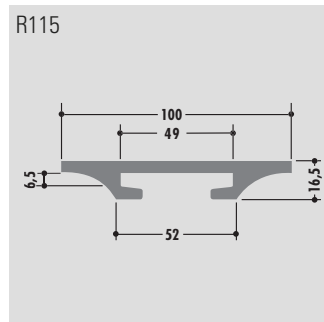
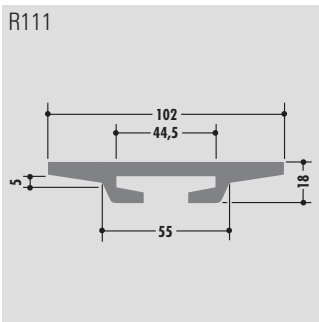
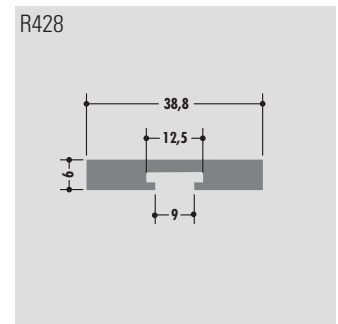
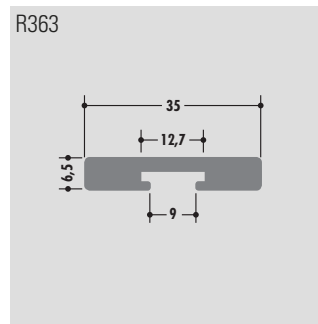
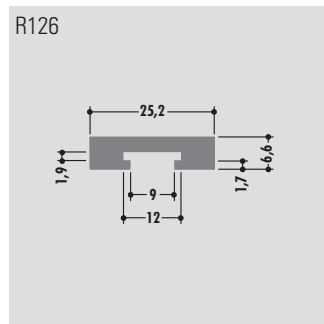
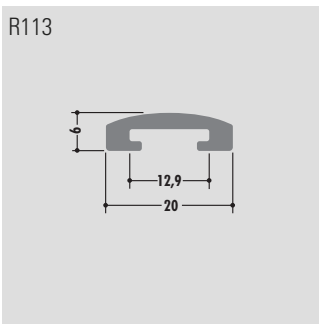
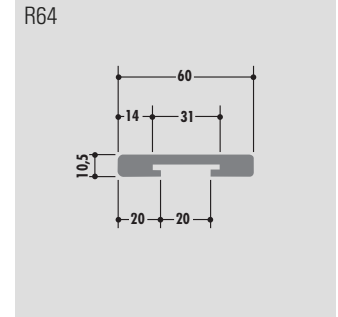
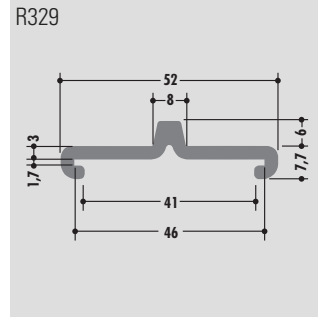
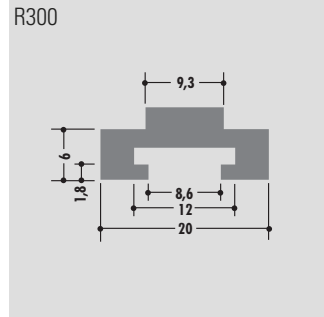
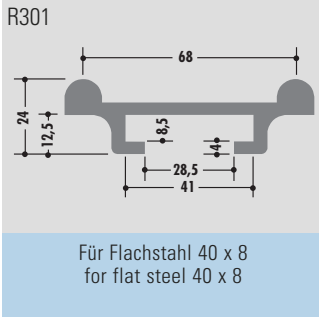

C-Profile C-profiles

Standardlänge: 6000 mm oder Rollenware
 Qualitäten: M-natur, M-schwarz, M-grün (PE-UHMW/PE 1000)
 Standard length: 6000 mm or in coils
 Qualities: M-natural, M-black, M-green (PE-UHMW/PE 1000)

Rollenlänge ca. 60 m
 Length per roll ca. 60 m

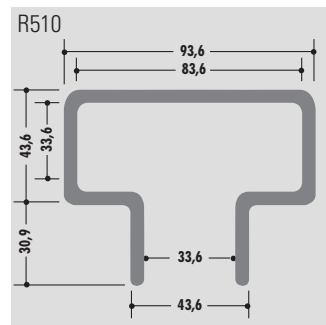
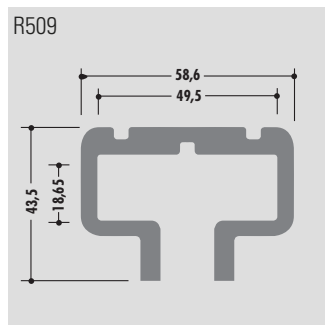
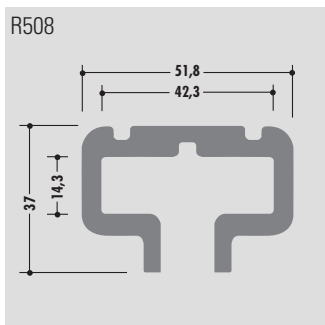
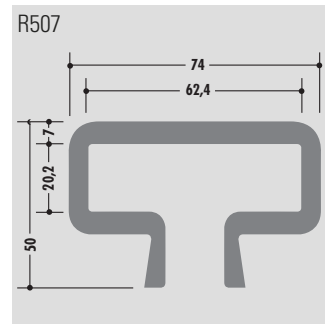
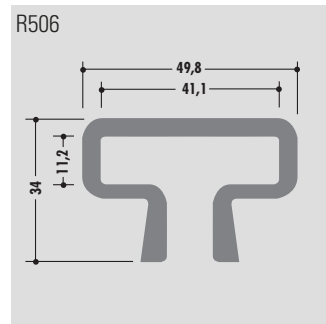
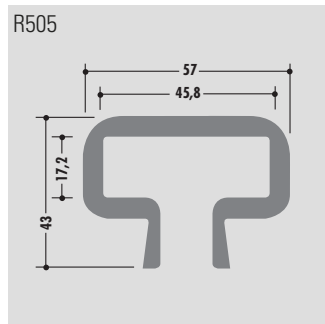
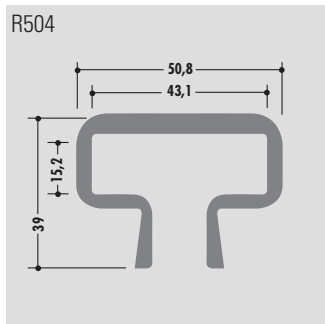
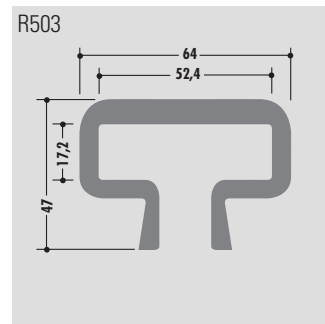
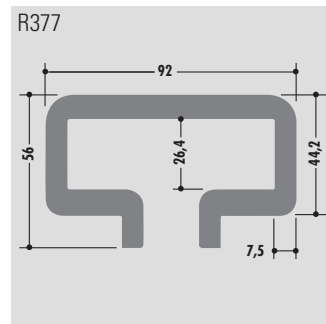
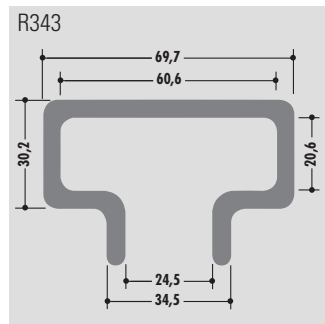
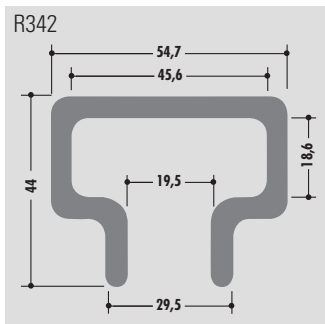
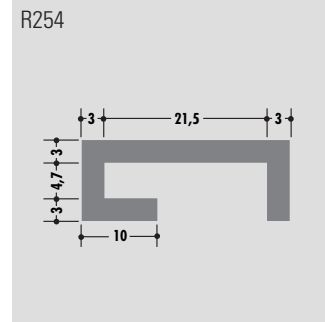
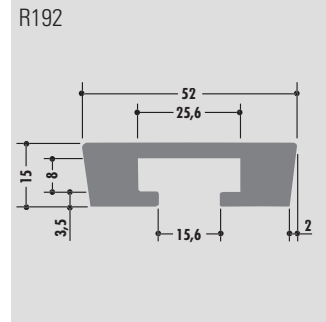
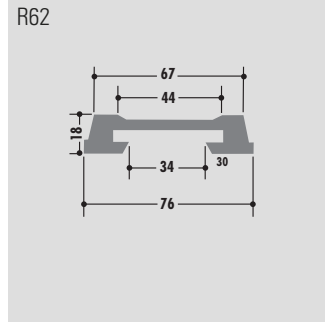
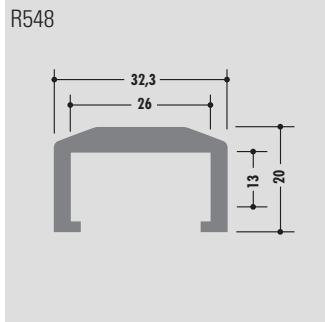

Z-Profile Z-profiles
L-Profile L-profiles
Klemmprofile Clamp-profiles
T-Profile T-profiles
U-Profile U-profiles
C-Profile C-profiles
Halbrund-Profile Round bar cover
Rohre Tubes
Seitenführungsprofile Side guide profile
Vierkantprofile Square-profiles
Clip-Profile Clip-profiles
Spezial-Profile Special-profiles
Bandmaterial Wear strips
Folien Film

Halbrund-Profil Round bar cover

Standardlänge: 6000 mm oder Rollenware
 Qualitäten: M-natur, M-schwarz, M-grün (PE-UHMW/PE 1000)
 Standard length: 6000 mm or in coils
 Qualities: M-natural, M-black, M-green (PE-UHMW/PE 1000)

R11

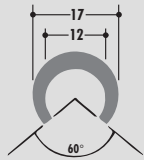

Für Rundstahl \varnothing 12 mm
 for roundbar \varnothing 12 mm

R95

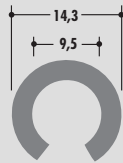

Für Rundstahl \varnothing 10 mm
 for roundbar \varnothing 10 mm

R414

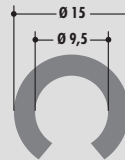

Für Rundstahl \varnothing 10 mm
 for roundbar \varnothing 10 mm

R415

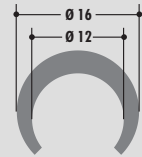

Für Rundstahl \varnothing 12 mm
 for roundbar \varnothing 12 mm

R425

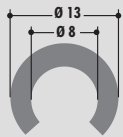

Für Rundstahl \varnothing 8 mm
 for roundbar \varnothing 8 mm

R97

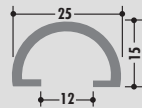

Rollenlänge ca. 60 m
 Length per roll ca. 60 m

R283

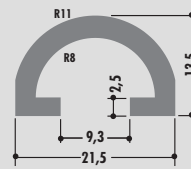

Rollenlänge ca. 60 m
 Length per roll ca. 60 m

Rohre Tubes

Standardlänge: 6000 mm oder Rollenware
 Qualitäten: M-natur, M-schwarz, M-grün (PE-UHMW/PE 1000)
 Standard length: 6000 mm or in coils
 Qualities: M-natural, M-black, M-green (PE-UHMW/PE 1000)

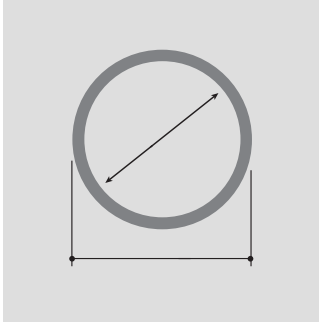

Profile Profiles	Außendurchmesser Outside diameter	Innendurchmesser Inside diameter
R390	28	22,8
R346	43	37
R511	50,6	30,8
R307	51	44
R308	63	55
R314	80	67
R347	90	80
R383	100	90
R366	128	104
R348	136	120
R367	160	136
R368	200	176

Z-Profile
Z-profiles

L-Profile
L-profiles

Klemmprofile
Clamp-profiles

T-Profile
T-profiles

U-Profile
U-profiles

C-Profile
C-profiles

Halbrund-Profil
Round bar cover

Rohre
Tubes

Seitenführungsprofil
Side guide profile

Vierkantprofil
Square-profiles

Clip-Profil
Clip-profiles

Spezial-Profil
Special-profiles

Bandmaterial
Wear strips

Folien
Film

Seitenführungsprofile Side guide profile

Standardlänge: 6000 mm oder Rollenware
 Qualitäten: M-natur, M-schwarz, M-grün (PE-UHMW/PE 1000)
 Standard length: 6000 mm or in coils
 Qualities: M-natural, M-black, M-green (PE-UHMW/PE 1000)

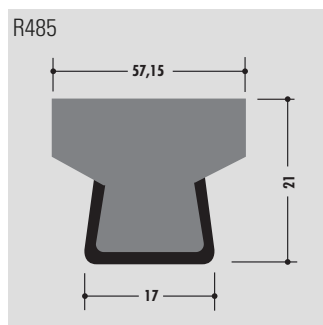
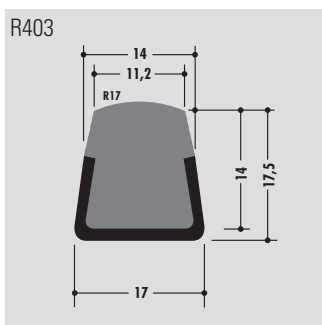
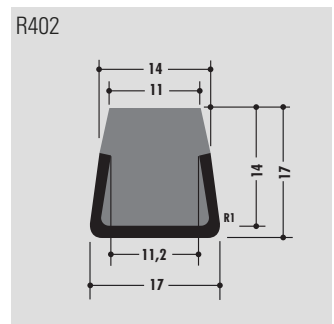
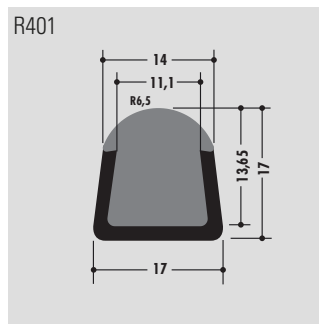
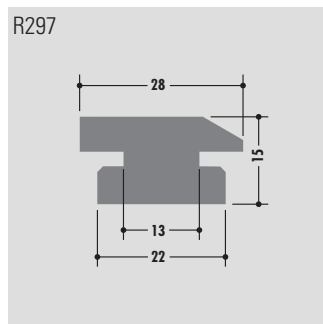
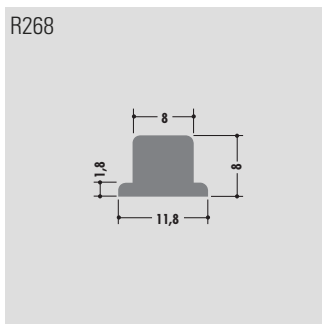
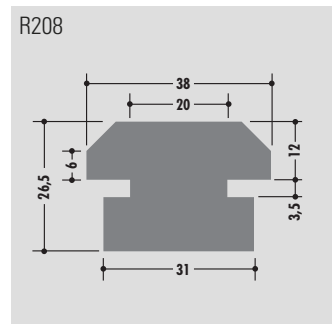
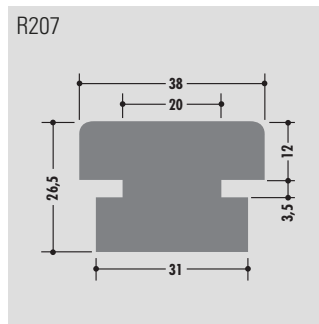
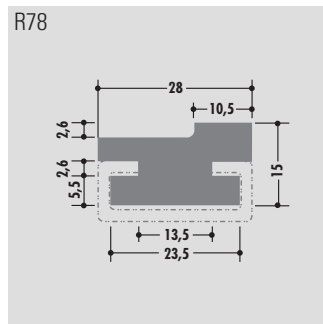
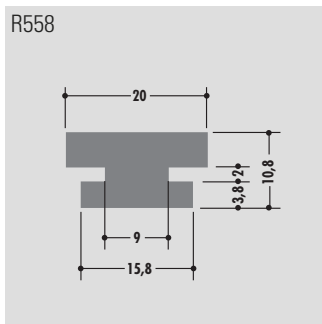
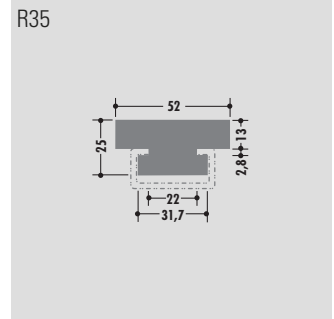
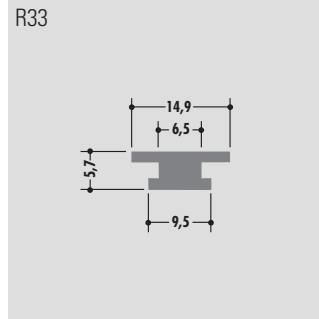
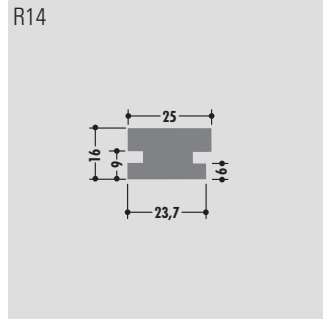
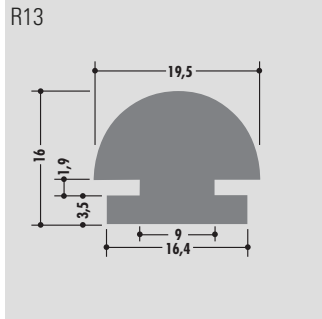

Viereck-Profile Square-profiles

Standardlänge: 6000 mm oder Rollenware
 Qualitäten: M-natur, M-schwarz, M-grün (PE-UHMW/PE 1000)
 Standard length: 6000 mm or in coils
 Qualities: M-natural, M-black, M-green (PE-UHMW/PE 1000)

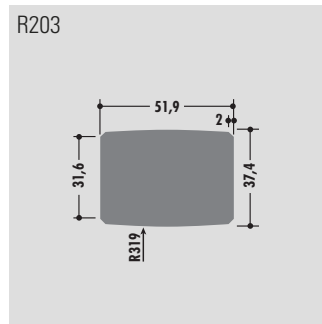
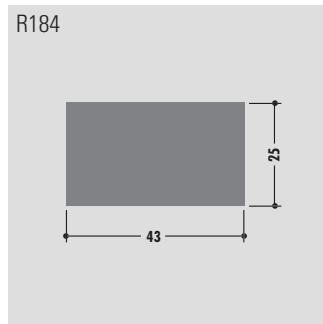
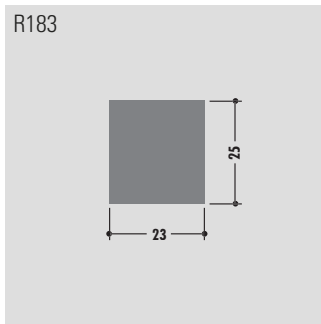
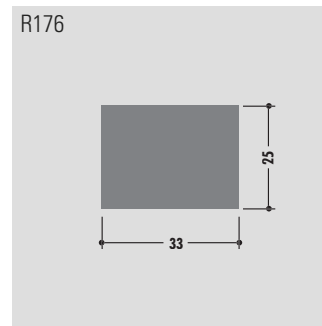
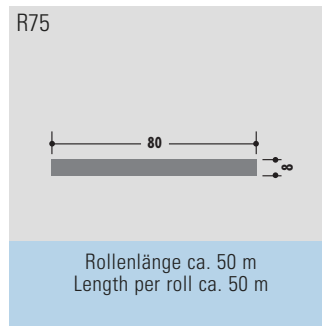
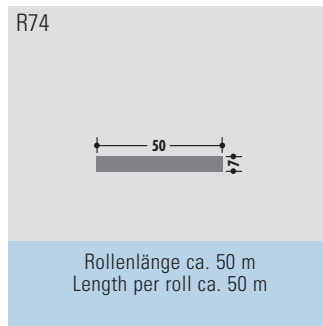
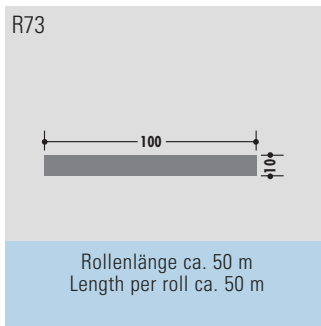
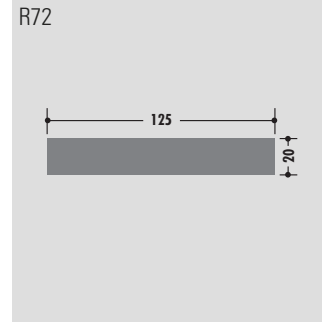
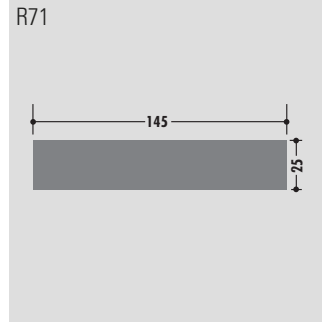
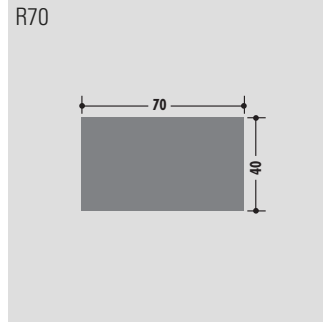
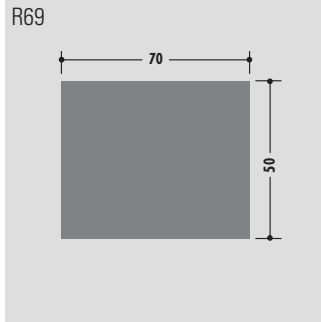

Z-Profile
Z-profiles

L-Profile
L-profiles

Klemmprofile
Clamp-profiles

T-Profile
T-profiles

U-Profile
U-profiles

C-Profile
C-profiles

Halbrund-Profile
Round bar cover

Rohre
Tubes

Seitenführungsprofile
Side guide profile

Viereckprofile
Square-profiles

Clip-Profile
Clip-profiles

Spezial-Profile
Special-profiles

Bandmaterial
Wear strips

Folien
Film

Clip-Profile Clip-profiles

Standardlänge: 6000 mm oder Rollenware
 Qualitäten: M-natur, M-schwarz, M-grün (PE-UHMW/PE 1000)
 Standard length: 6000 mm or in coils
 Qualities: M-natural, M-black, M-green (PE-UHMW/PE 1000)

R77

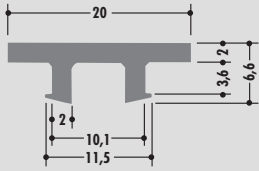

R87

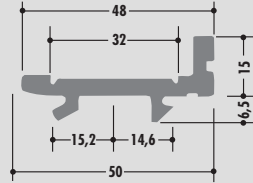

R90

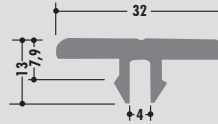

R156

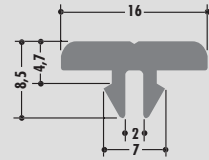

R157

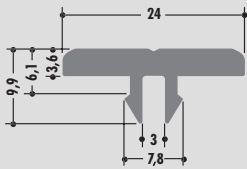

R196

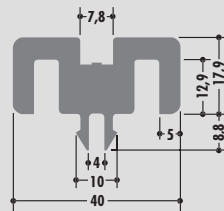

R197

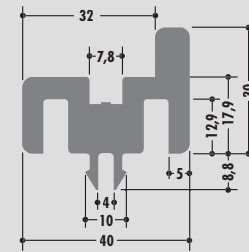

R249

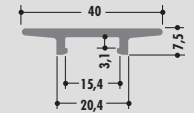

R250

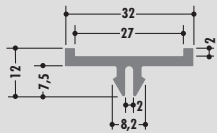

R566

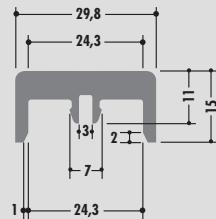

Spezial-Profil Special-profiles

Standardlänge: 6000 mm oder Rollenware
 Qualitäten: M-natur, M-schwarz, M-grün (PE-UHMW/PE 1000)
 Standard length: 6000 mm or in coils
 Qualities: M-natural, M-black, M-green (PE-UHMW/PE 1000)

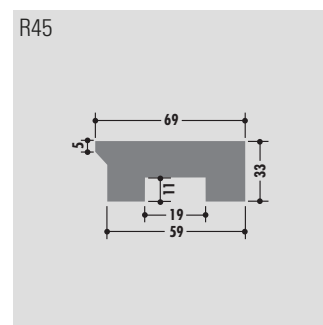
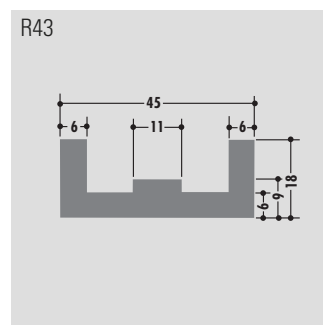
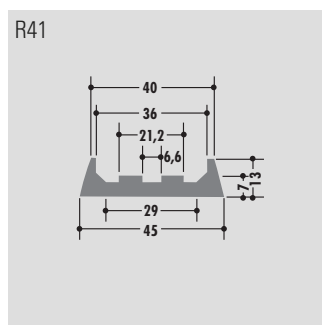
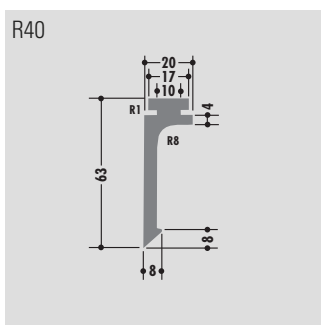
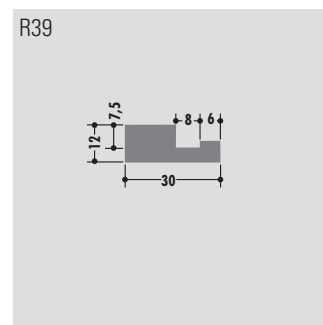
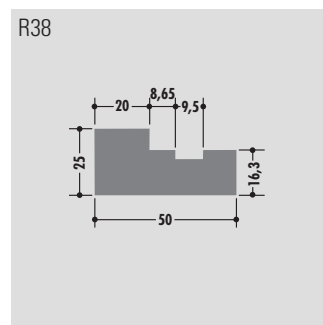
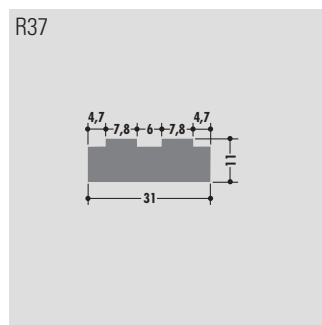
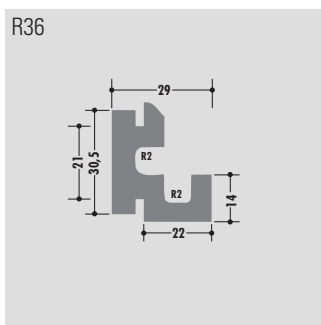
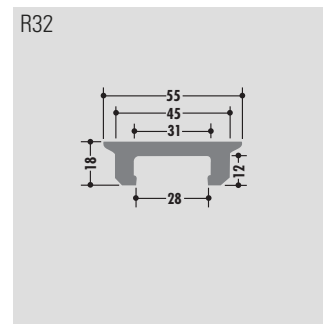
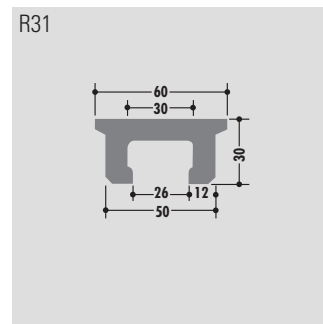
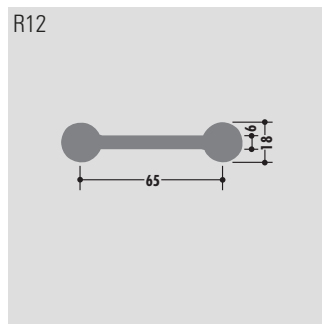
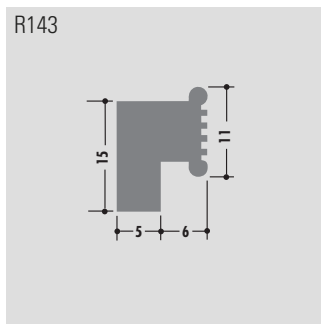
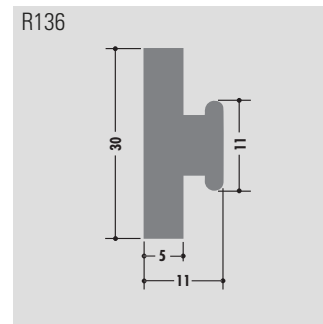
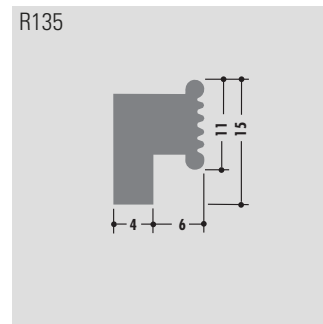
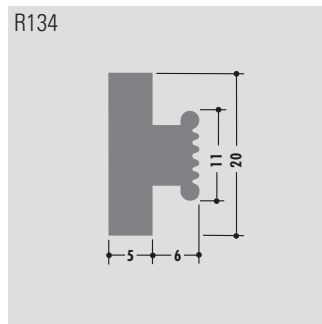
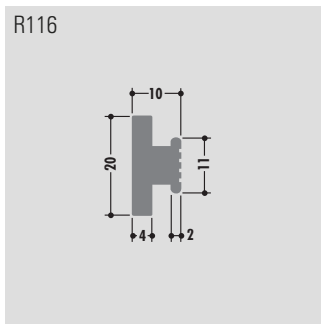
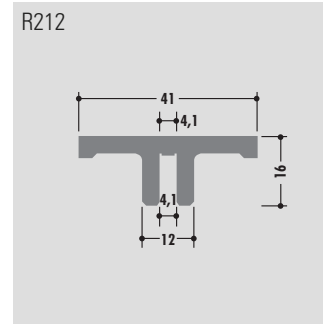
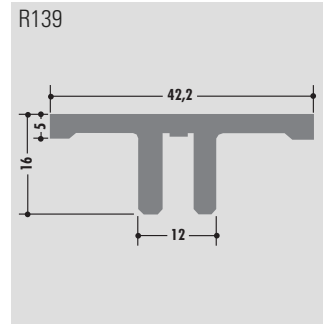
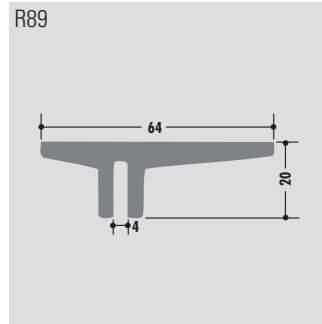
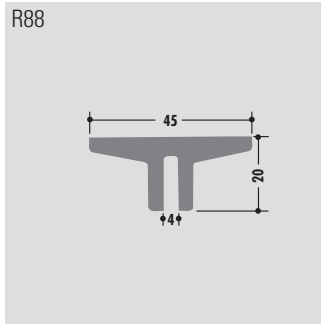

Z-Profile Z-profiles
L-Profile L-profiles
Klemmprofile Clamp-profiles
T-Profile T-profiles
U-Profile U-profiles
C-Profile C-profiles
Halbrund-Profil Round bar cover
Rohre Tubes
Seitenführungsprofile Side guide profile
Vierkantprofile Square-profiles
Clip-Profil Clip-profiles
Spezial-Profil Special-profiles
Bandmaterial Wear strips
Folien Film

Spezial-Profile Special-profiles

Standardlänge: 6000 mm oder Rollenware
 Qualitäten: M-natur, M-schwarz, M-grün (PE-UHMW/PE 1000)
 Standard length: 6000 mm or in coils
 Qualities: M-natural, M-black, M-green (PE-UHMW/PE 1000)

R46

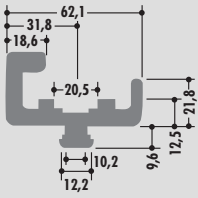

R48

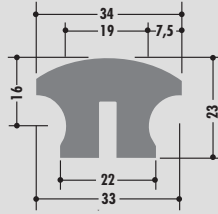

R365

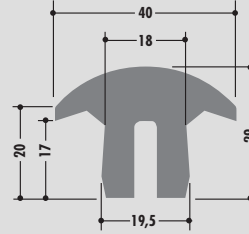

R515

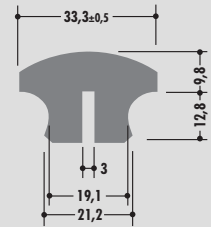

R49

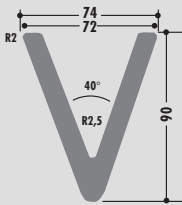

R53

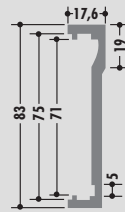

R56

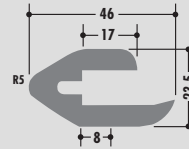

R58

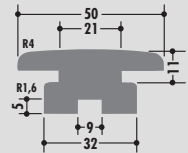

R65

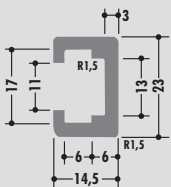

R66

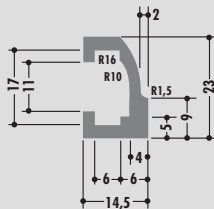

R67

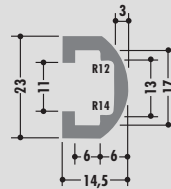

R80

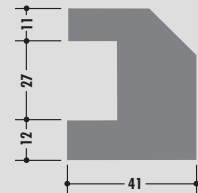

R81

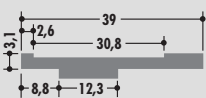

R82

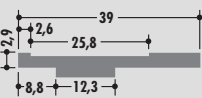

R85

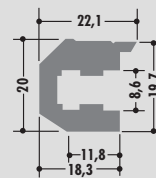

R86

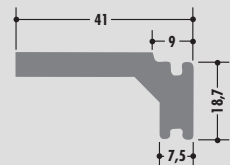

R91

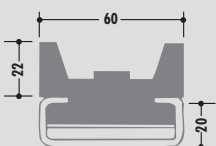

R92

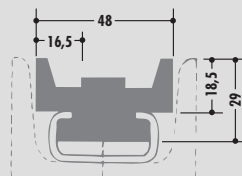

R93

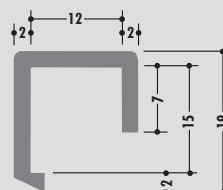

R96

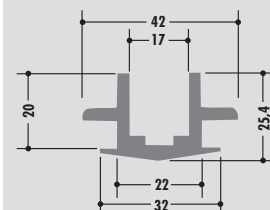

Spezial-Profil Special-profiles

Standardlänge: 6000 mm oder Rollenware
 Qualitäten: M-natur, M-schwarz, M-grün (PE-UHMW/PE 1000)
 Standard length: 6000 mm or in coils
 Qualities: M-natural, M-black, M-green (PE-UHMW/PE 1000)

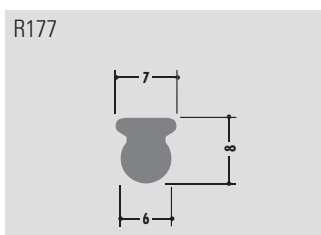
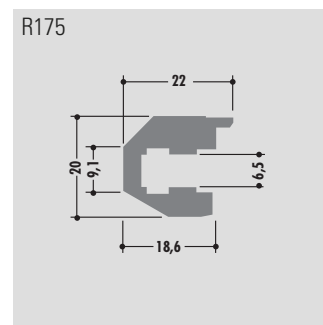
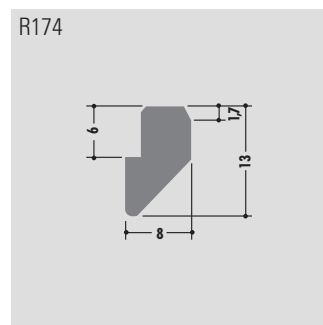
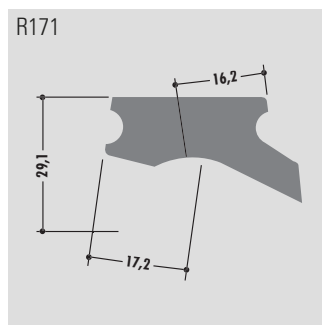
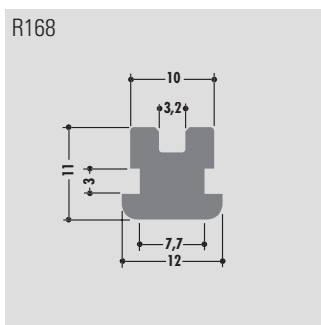
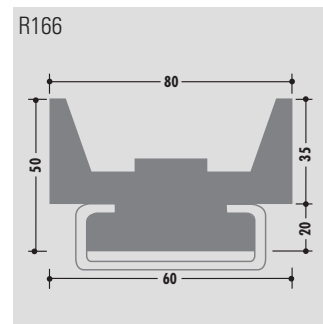
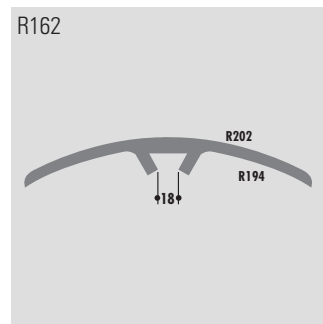
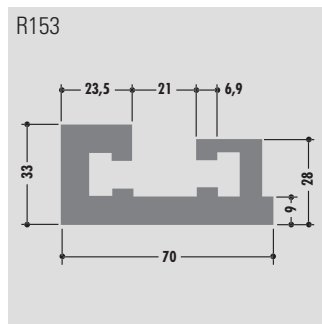
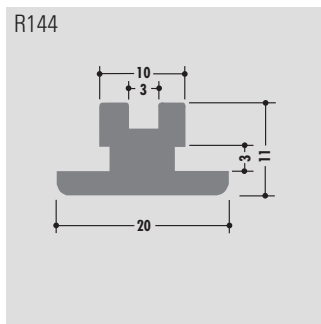
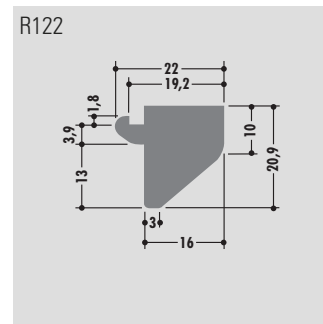
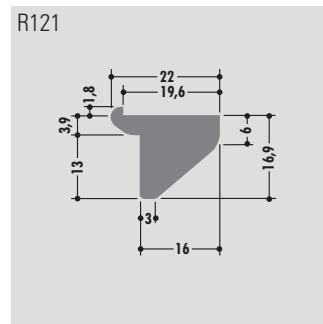
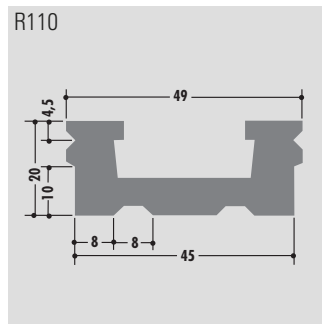
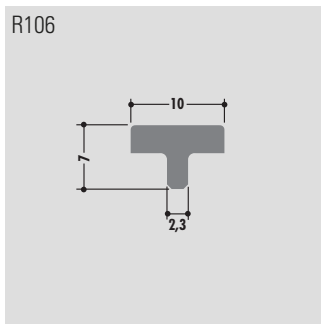
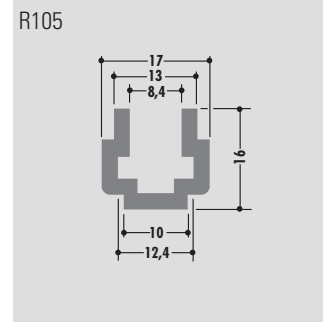
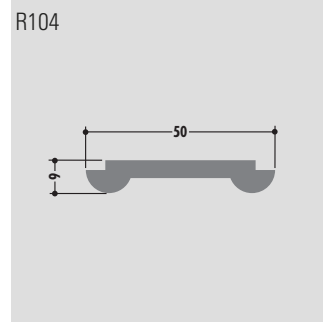
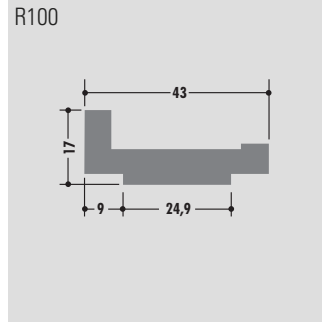
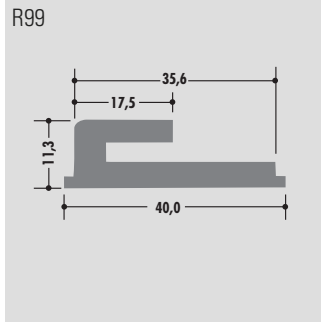

Rollenlänge ca. 60 m
 Length per roll ca. 60 m

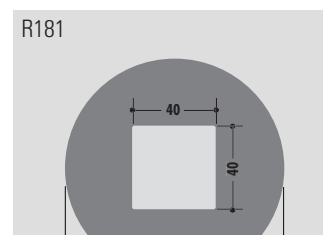
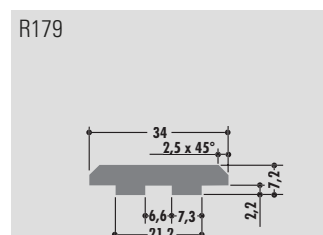
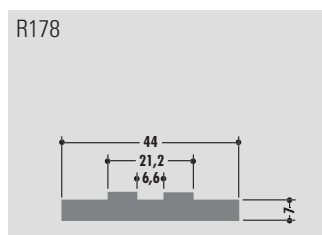

Z-Profile Z-profiles
L-Profile L-profiles
Klemmprofile Clamp-profiles
T-Profile T-profiles
U-Profile U-profiles
C-Profile C-profiles
Halbrund-Profil Round bar cover
Rohre Tubes
Seitenführungsprofile Side guide profile
Vierkantprofile Square-profiles
Clip-Profile Clip-profiles
Spezial-Profil Special-profiles
Bandmaterial Wear strips
Folien Film

Spezial-Profile Special-profiles

Standardlänge: 6000 mm oder Rollenware
 Qualitäten: M-natur, M-schwarz, M-grün (PE-UHMW/PE 1000)
 Standard length: 6000 mm or in coils
 Qualities: M-natural, M-black, M-green (PE-UHMW/PE 1000)

R185

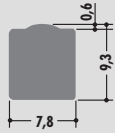

R189

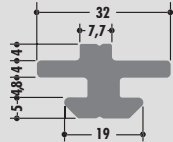

R193

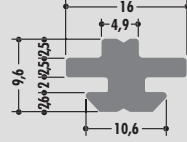

R194

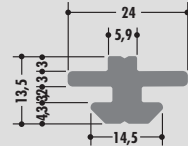

R195

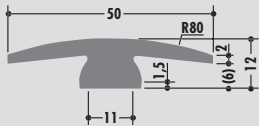

R198

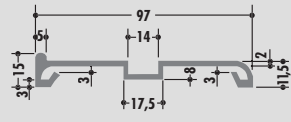

R199

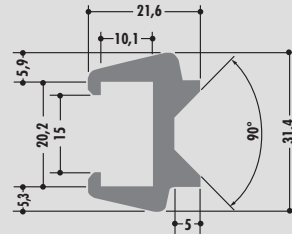

R201

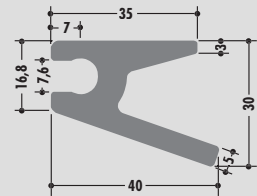

R202

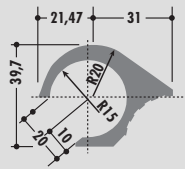

R204

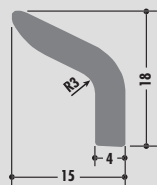

R215

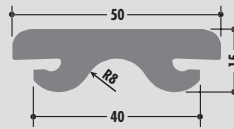

R555

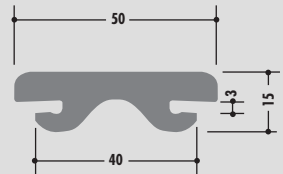

R224

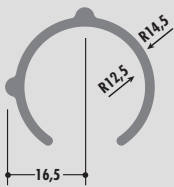

R225

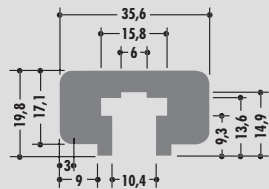

R230

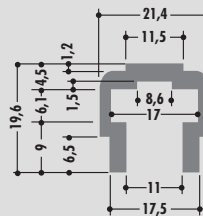

R232

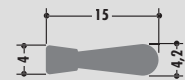

R233

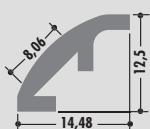

R238

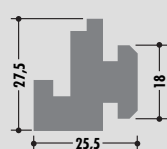

R242

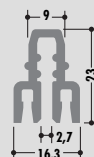

R251

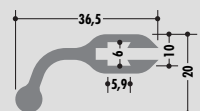

Spezial-Profil Special-profiles

Standardlänge: 6000 mm oder Rollenware
 Qualitäten: M-natur, M-schwarz, M-grün (PE-UHMW/PE 1000)
 Standard length: 6000 mm or in coils
 Qualities: M-natural, M-black, M-green (PE-UHMW/PE 1000)

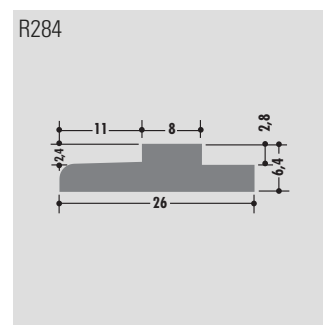
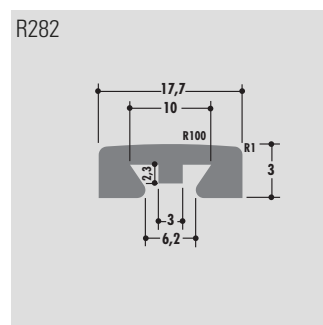
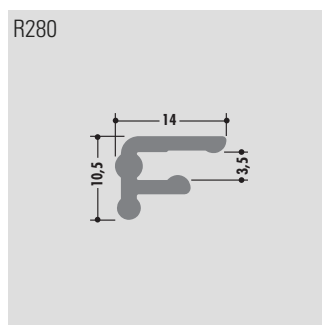
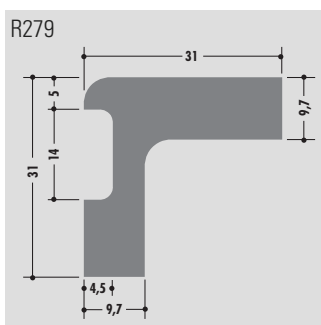
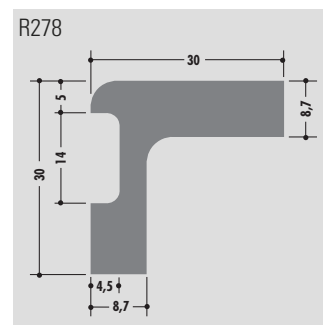
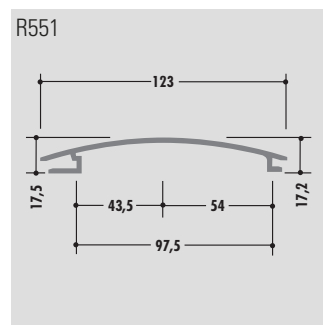
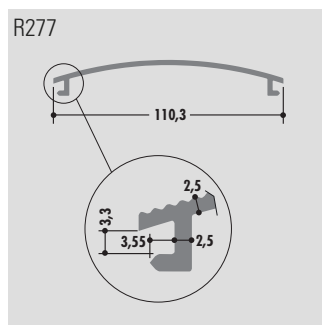
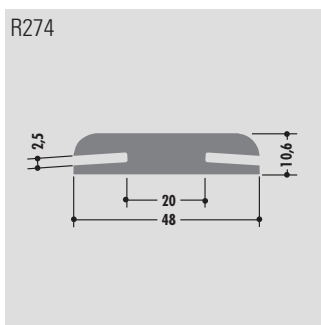
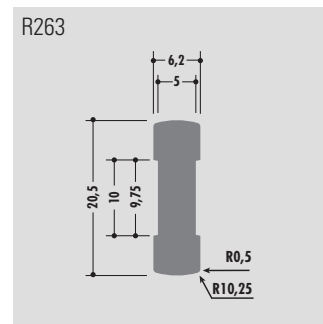
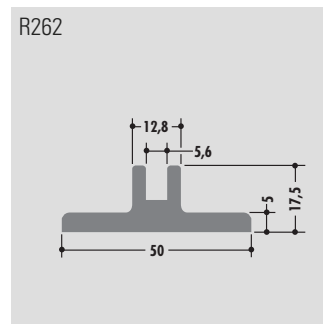
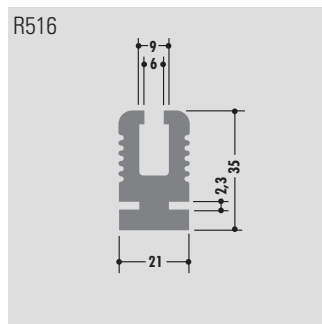
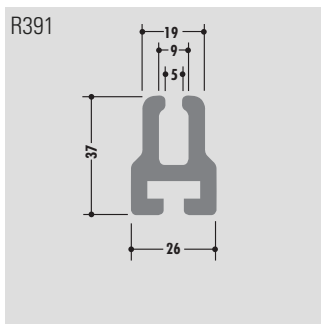
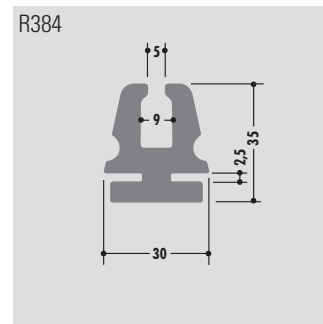
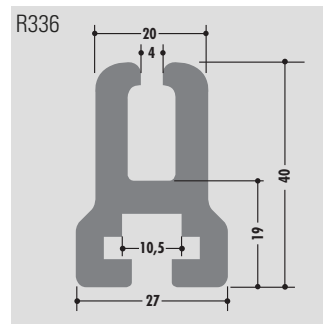
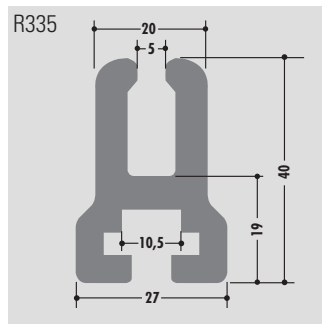
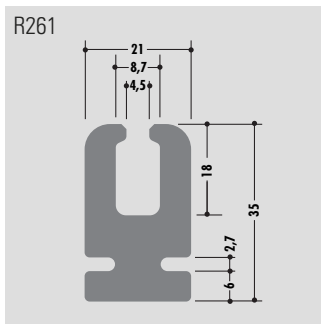
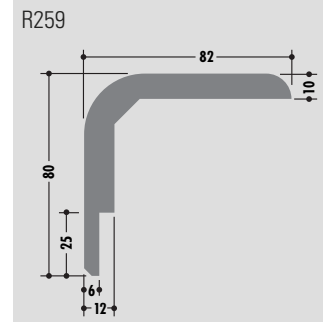
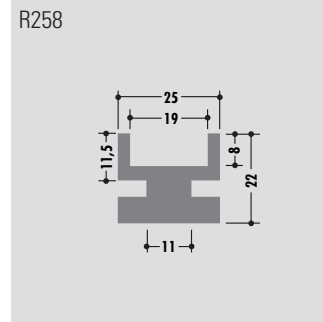
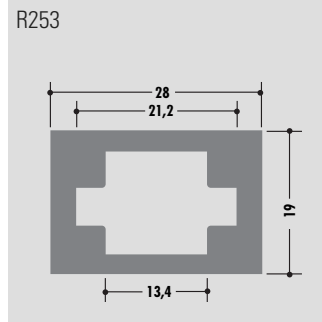
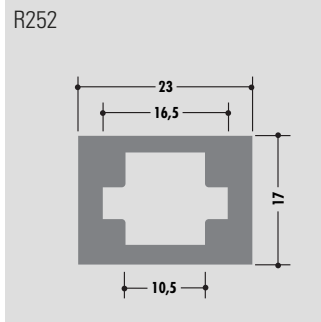

Z-Profile Z-profiles
L-Profile L-profiles
Klemmprofile Clamp-profiles
T-Profile T-profiles
U-Profile U-profiles
C-Profile C-profiles
Halbrund-Profile Round bar cover
Rohre Tubes
Seitenführungsprofile Side guide profile
Vierkantprofile Square-profiles
Clip-Profile Clip-profiles
Spezial-Profile Special-profiles
Bandmaterial Wear strips
Folien Film

Spezial-Profile Special-profiles

Standardlänge: 6000 mm oder Rollenware
 Qualitäten: M-natur, M-schwarz, M-grün (PE-UHMW/PE 1000)
 Standard length: 6000 mm or in coils
 Qualities: M-natural, M-black, M-green (PE-UHMW/PE 1000)

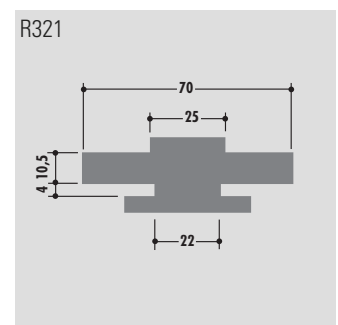
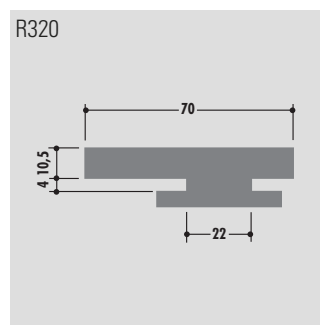
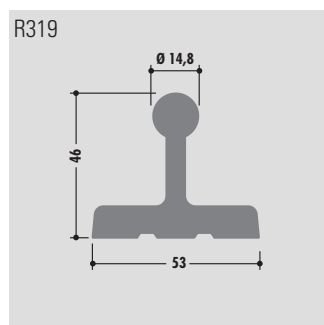
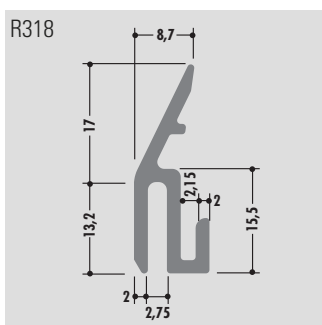
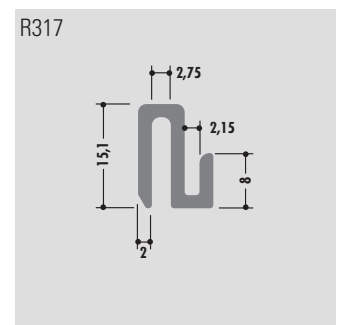
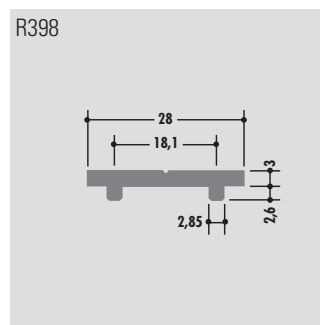
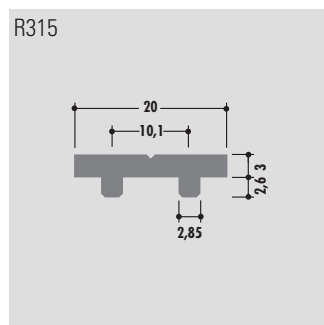
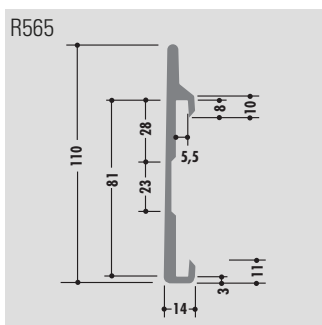
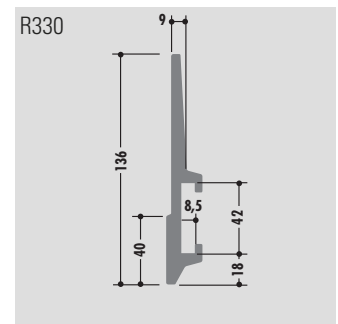
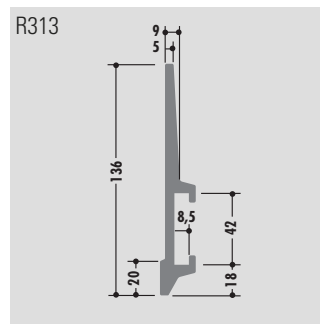
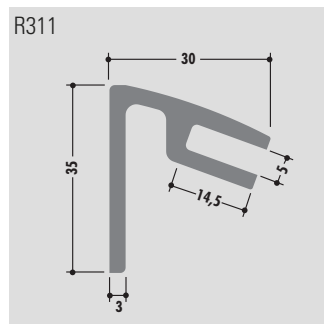
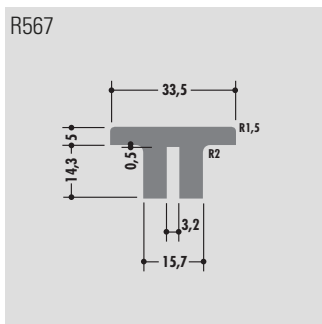
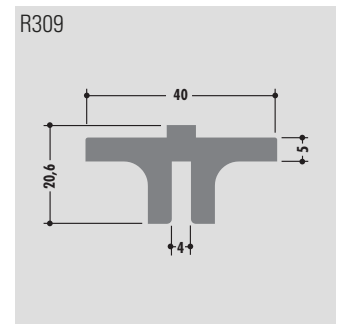
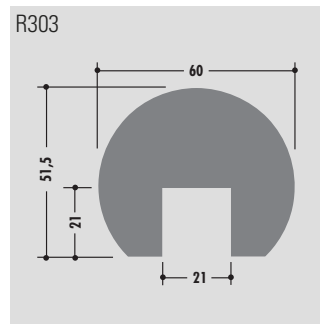
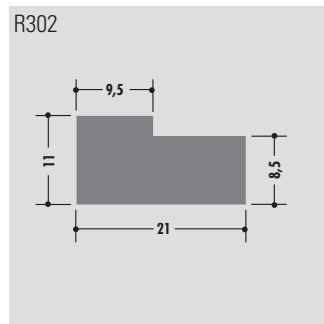
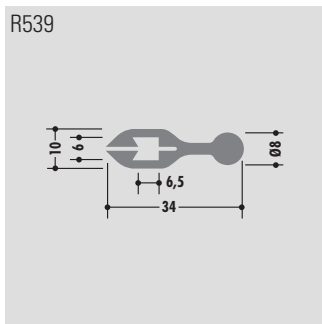
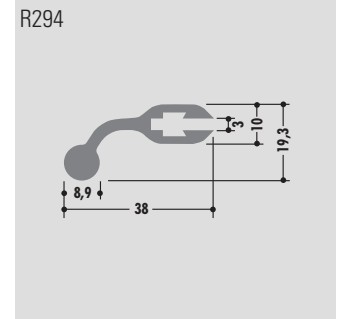
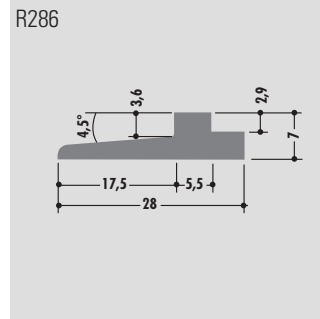
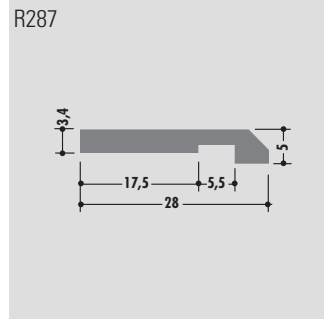
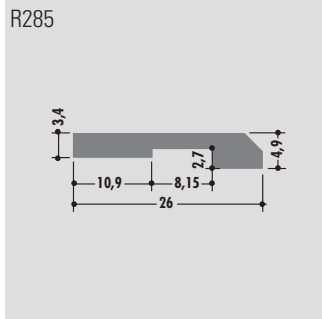

Spezial-Profil Special-profiles

Standardlänge: 6000 mm oder Rollenware
 Qualitäten: M-natur, M-schwarz, M-grün (PE-UHMW/PE 1000)
 Standard length: 6000 mm or in coils
 Qualities: M-natural, M-black, M-green (PE-UHMW/PE 1000)

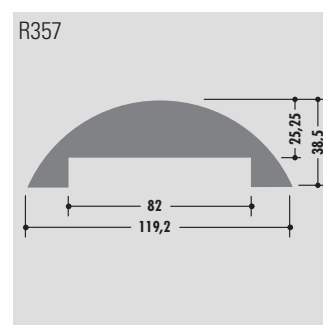
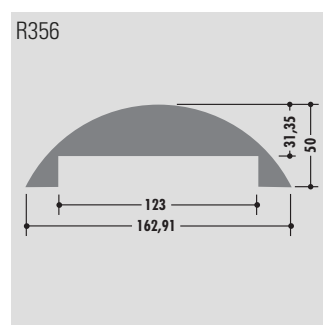
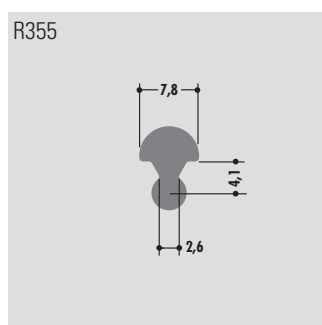
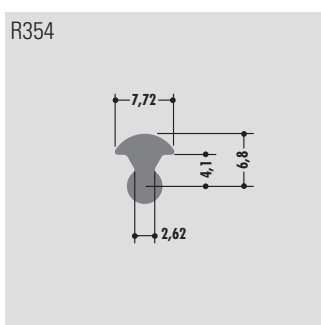
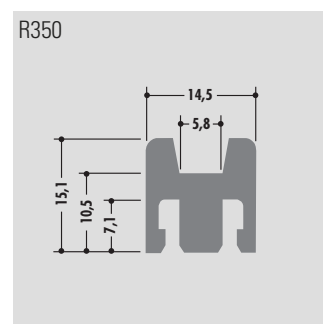
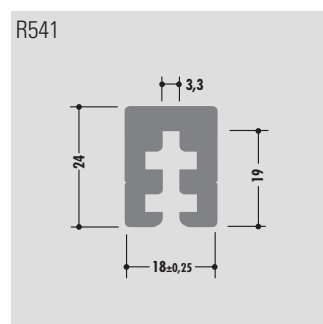
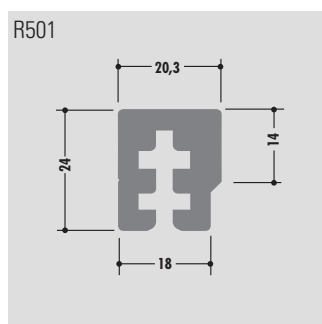
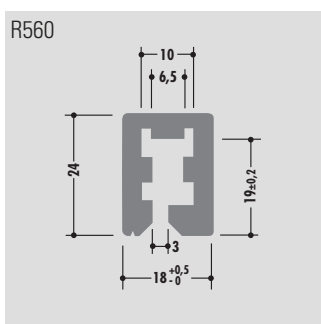
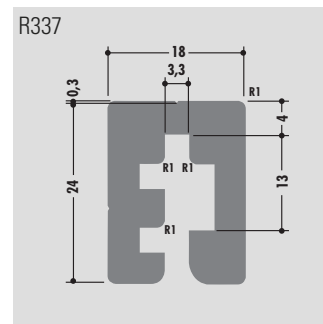
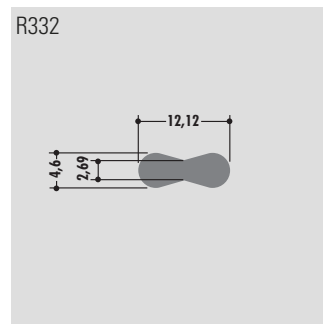
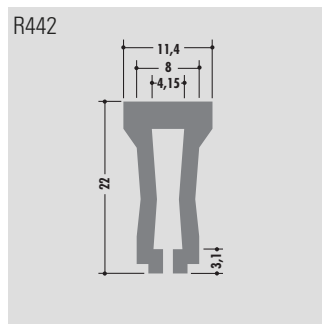
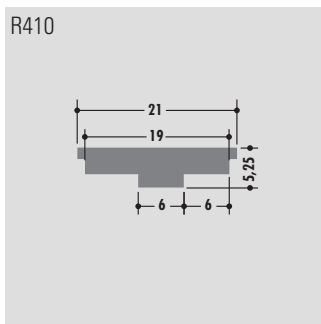
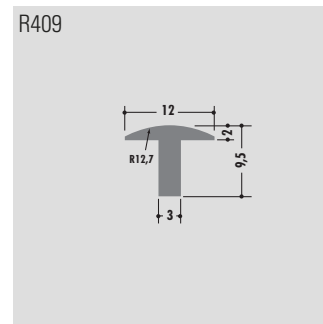
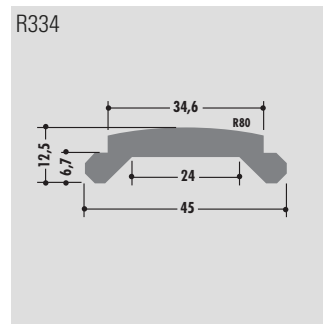
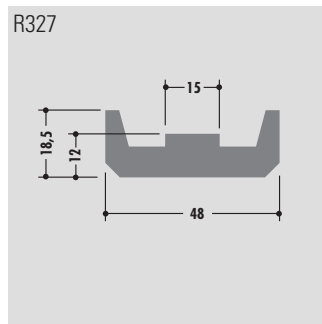
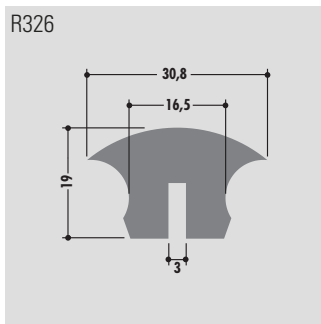
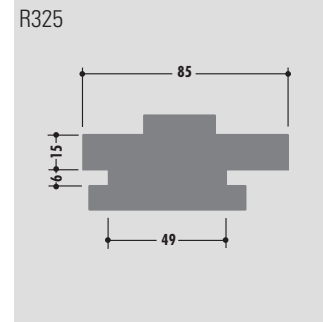
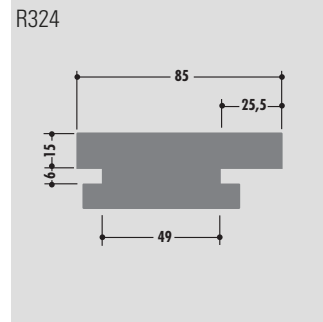
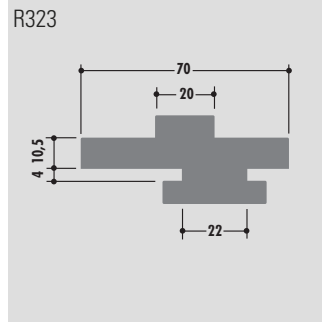
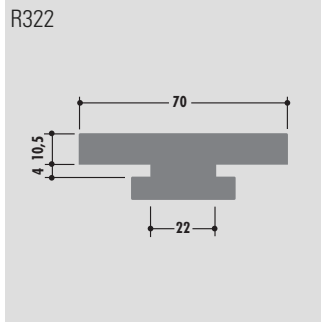

Z-Profile Z-profiles
L-Profile L-profiles
Klemmprofile Clamp-profiles
T-Profile T-profiles
U-Profile U-profiles
C-Profile C-profiles
Halbrund-Profil Round bar cover
Rohre Tubes
Seitenführungsprofile Side guide profile
Vierkantprofile Square-profiles
Clip-Profil Clip-profiles
Spezial-Profil Special-profiles
Bandmaterial Wear strips
Folien Film

Spezial-Profile Special-profiles

Standardlänge: 6000 mm oder Rollenware
 Qualitäten: M-natur, M-schwarz, M-grün (PE-UHMW/PE 1000)
 Standard length: 6000 mm or in coils
 Qualities: M-natural, M-black, M-green (PE-UHMW/PE 1000)

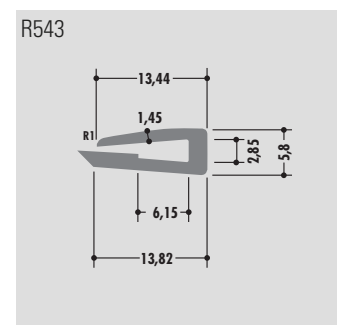
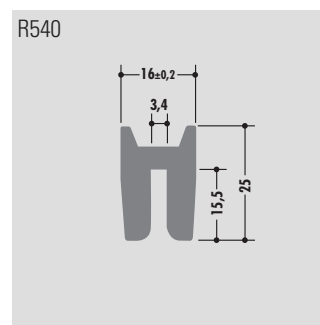
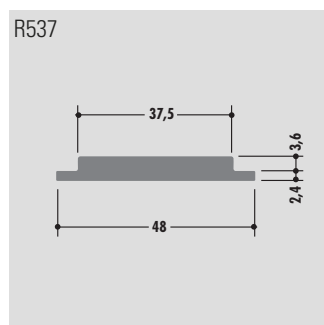
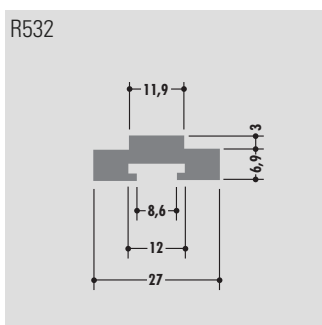
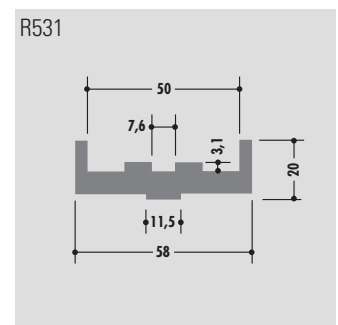
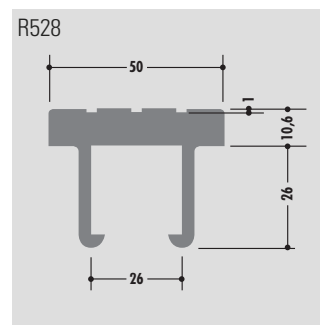
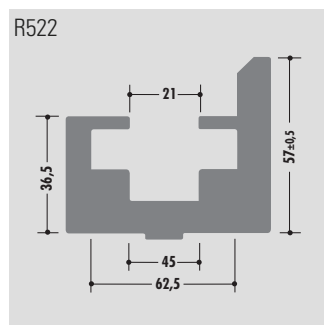
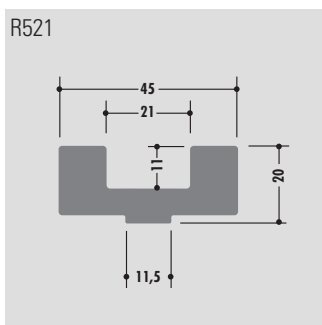
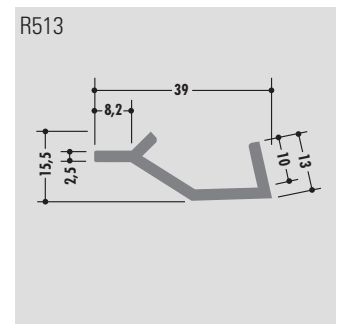
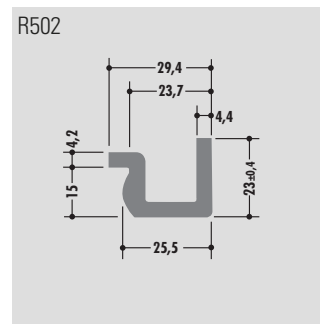
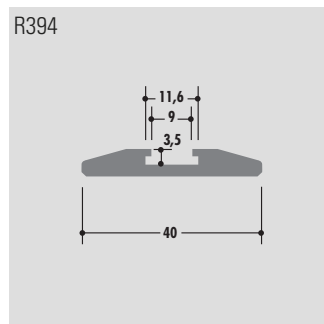
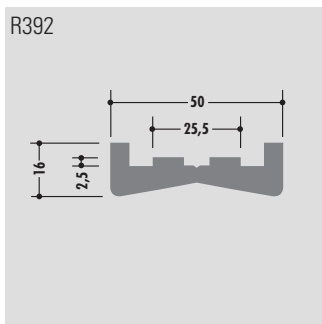
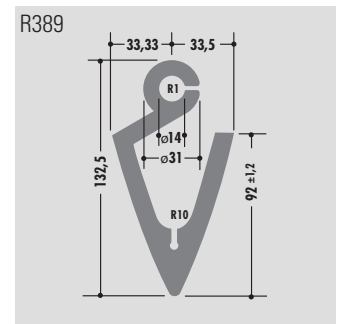
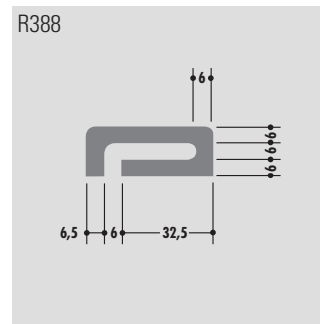
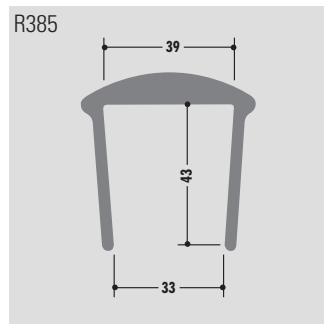
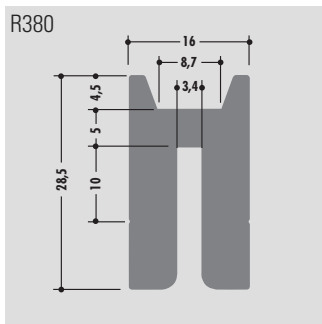
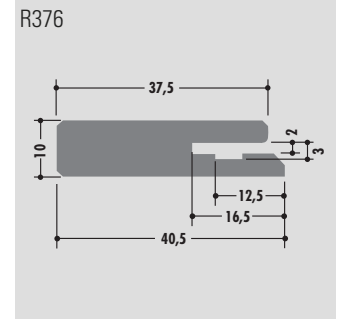
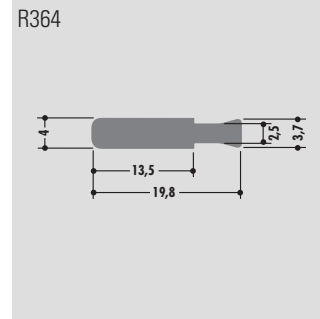
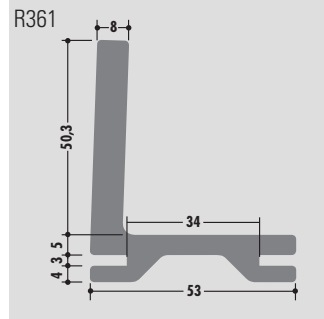
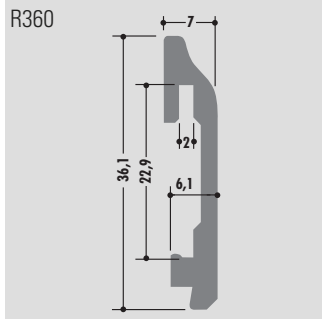

Spezial-Profile Special-profiles

Standardlänge: 6000 mm oder Rollenware
 Qualitäten: M-natur, M-schwarz, M-grün (PE-UHMW/PE 1000)
 Standard length: 6000 mm or in coils
 Qualities: M-natural, M-black, M-green (PE-UHMW/PE 1000)

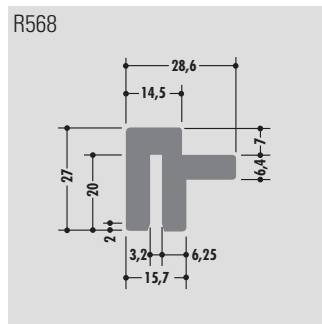
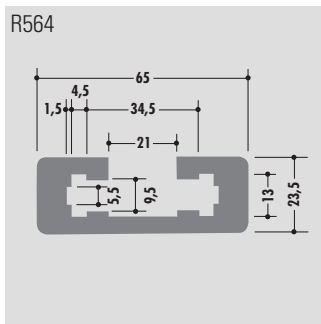
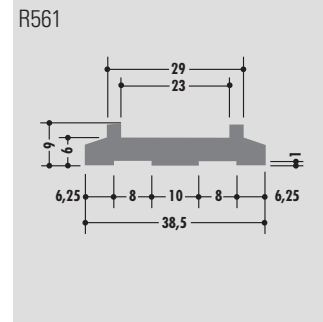
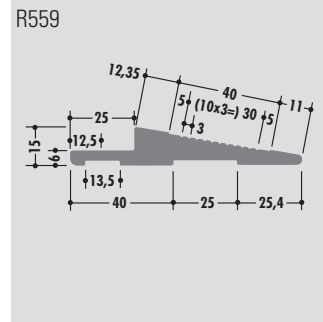
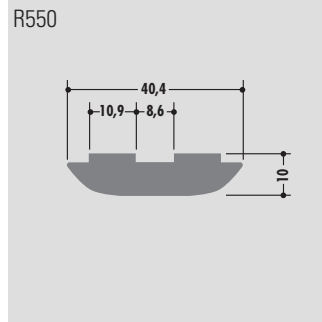
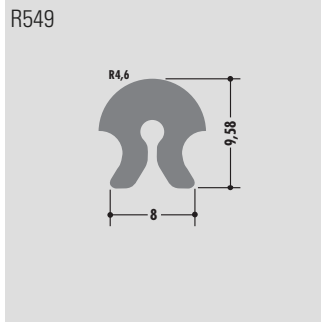

Z-Profile
Z-profiles

L-Profile
L-profiles

Klemmprofile
Clamp-profiles

T-Profile
T-profiles

U-Profile
U-profiles

C-Profile
C-profiles

Halbrund-Profil
Round bar cover

Rohre
Tubes

Seitenführungsprofil
Side guide profile

Vierkantprofil
Square-profiles

Clip-Profil
Clip-profiles

Spezial-Profil
Special-profiles

Bandmaterial
Wear strips

Folien
Film

Bandmaterial, geschält Wear strips, skived

- für Ketten nach DIN 8187
- for chains to DIN 8187

Bandbreite Width mm	Bandlänge bei Banddicke Length at thickness							
	1 mm	2 mm	3 mm	4 mm	5 mm	6 mm	7 mm	8 mm
15								
18							-	-
20								
25								
30								
35								
40	270 m	135 m	85 m	65 m	50 m	40 m	35 m	30 m
45								
50								
55								
60								
70								
80								
90								
100	160 m	80 m	50 m	38 m	32 m	25 m	22 m	-
110								

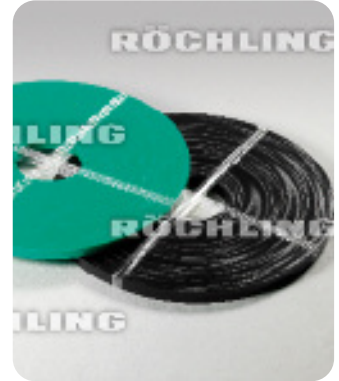

Bemerkungen: Sonderabmessungen auf Anfrage.

Max. Abmessungen: 300 mm Breite, 0,25-3 mm Dicke. Toleranzen: Dicke +0,1/-0,3 mm, Breite ±0,3 mm

Notes: Special dimensions on request.

Max. dimension: 300 mm width, 0,25-3 mm thickness. Tolerances: Thickness +0,1/-0,3 mm, Width ±0,3 mm

Folien, geschält

Film, skived

Breite ¹⁾ Width ¹⁾ mm	Folienlänge / Length											
	Foliendicke / Thickness											
	0,25	0,50	0,75	1,00	1,25	1,50	1,75	2,00	2,25	2,50	2,75	3,00
100 ... 300	136 m	68 m	45 m	34 m	27 m	22 m	19 m	17 m	15 m	13 m	12 m	11 m

¹⁾ Folien sind in jeder gewünschten Breite von 100 – 300 mm lieferbar

¹⁾ Films are deliverable in a width of 100 – 300 mm



Z-Profil
Z-profiles

L-Profil
L-profiles

Klemmprofil
Clamp-profiles

T-Profil
T-profiles

U-Profil
U-profiles

C-Profil
C-profiles

Halbrund-Profil
Round bar cover

Rohre
Tubes

Seitenführungsprofil
Side guide profile

Vierkantprofil
Square-profiles

Clip-Profil
Clip-profiles

Spezial-Profil
Special-profiles

Bandmaterial
Wear strips

Folien
Film



RÖCHLING

High Performance Plastics

EUROPE

GERMANY

Röchling Engineering Plastics KG

Röchlingstr. 1, 49733 Haren
info@roechling-plastics.com
www.roechling.com
Tel. +49 5934 701-0

Röchling Technische Kunststoffe KG

Planckstr. 3, 06686 Lützen
kontakt@roechling-luetzen.de
www.roechling-luetzen.de
Tel. +49 34444 308-200

Röchling Hydroma GmbH

Lemberger Str. 101, 66957 Ruppertsweiler
info@roechling-hydroma.com
www.roechling-hydroma.com
Tel. +49 6395 9222-0

Bayerschmidt Kunststoffe GmbH

Bayerschmidtweg 1, 93426 Roding
info@bayerschmidt.de
www.bayerschmidt.de
Tel. +49 9461 4026-0

Röchling Sustaplast KG Formtechnik

Lahnstr. 22, 56412 Nentershausen
formtechnik@sustaplast.de
www.roechling.com
Tel. +49 6485 889-0

DENMARK

Röchling Meta-Plast A/S

Tosjstrupvej 31, 8961 Allingåbro
sales@meta-plast.dk
www.meta-plast.dk
Tel. +45 8648 1711

FINLAND

Röchling Leripa Papertech Service Oy

Tarrankuja 1, 08500 Lohja
finland@leripa.com
www.leripa.com
Tel. +358 19 357991

FRANCE

Röchling Engineering Plastiques S.A.S.

2, Rue de Barcelone
69153 Décines Cedex/France
roechling.decines@roechling-engineering.fr
www.roechling.com
Tel. +33 472 148960

GREAT BRITAIN

Röchling Engineering Plastics (UK) Ltd.

Waterwells Drive, Quedgeley, Gloucester GL2 2AA
sales@roechling-plastics.co.uk
www.roechling-plastics.co.uk
Tel. +44 1452 72-7900

ITALY

Röchling Machined Plastics Italia s.r.l

Via Morena 66, 28024 Gozzano
info@roechling.it
Tel. +39 0322 95421

LATVIA

Meta-Plast S/A

Kapsedes Str. 2, LV-3402 Liepāja
letland@meta-plast.dk
www.meta-plast.dk
Tel. +371 6348 8539

AUSTRIA

Röchling Leripa Papertech GmbH & Co.KG

Röchlingstr. 1, 4151 Oepping
robaproducts@leripa.com
www.leripa.com
Tel. +43 7289 4611

SPAIN

Röchling Plásticos Técnicos S.A.U.

Ctra. Villena, s/n. - Apartado 34, 46880 Bocairent
comercial@roechling-plastics.es
www.roechling-plastics.es
Tel. +34 962 350165

CZECH REPUBLIC

Röchling Machined Plastics s.r.o

Průmyslová 705
39111 Planá nad Lužnicí
rmp@roechling-plastics.cz
www.roechling-plastics.cz
Tel. +420 381 211-875

ASIA

CHINA

Roehling Machined Components (Kunshan) Co., Ltd

No. 238 Chenfeng Road Kunshan City
Jiangsu Province 215300
info@roechling-kunshan.com
www.roechling-rmc.cn
Tel. +86 512 55132188

INDIA

Röchling Engineering Plastics (India) Pvt. Ltd.

201, 'A' Wing, Leo Building
24th Road, Khar West
400 052 Mumbai / India
info@roechling-india.com
www.roechling-india.com
Tel. +91 22 4217-8787

USA

Röchling Leripa Papertech LLC

710 Ford Street Kimberly, Wisconsin 54136
leripa.papertech@leripa.com
www.leripa.com
Tel. +1 920 954 9154

Röchling Machined Plastics

161 Westec Drive
15666 Mount Pleasant PA /USA
rmp@roechling.biz
www.roechling-plastics.us
Tel. +1 724 696-5200

