

Tidsrelæer

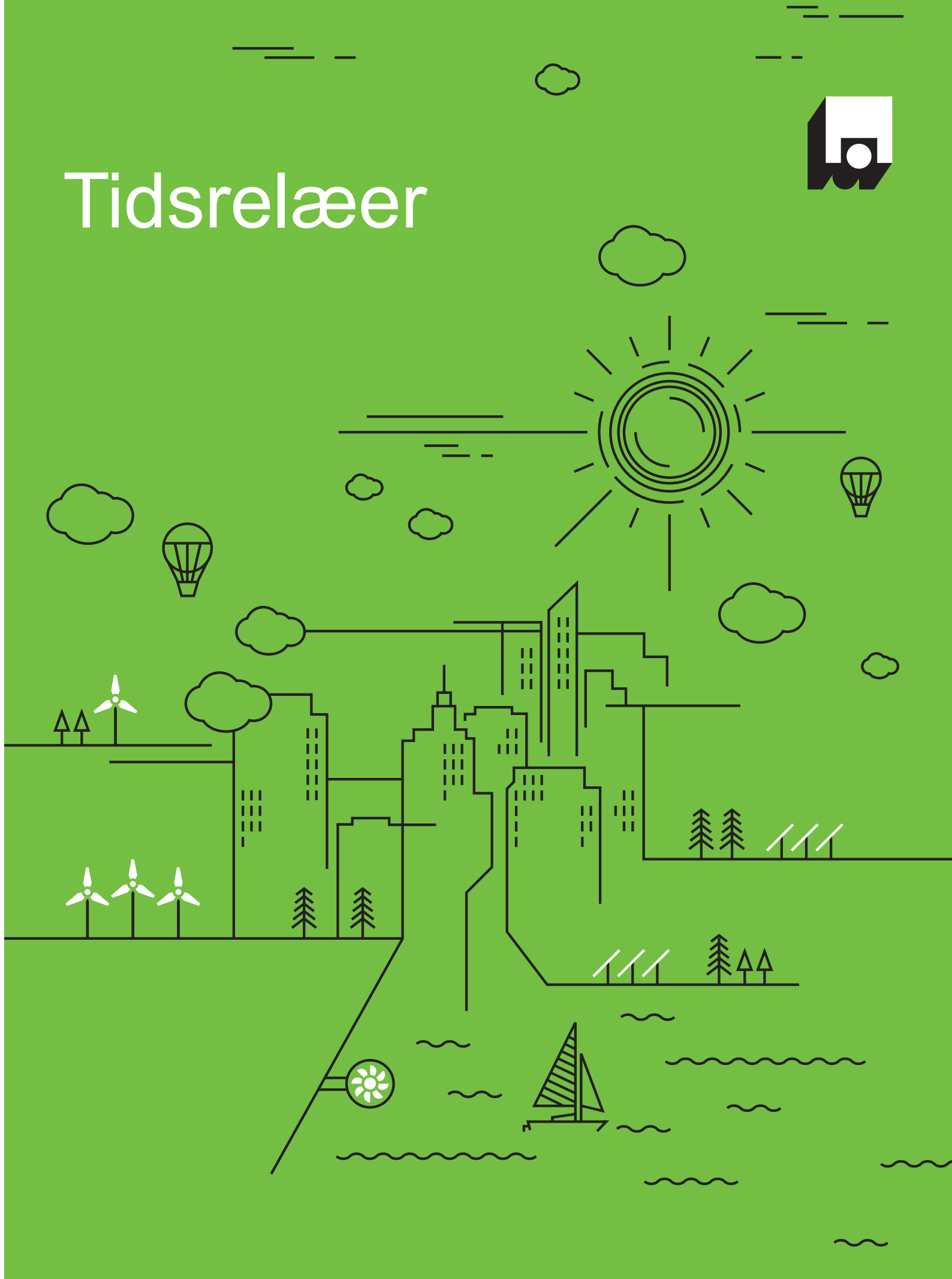

ENYA series
 Multifunction
 Up to 7 functions
 7 time ranges
 Wide input voltage range
 1 change over contact
 Width 17.5 mm
 Installation design



Technical data

1. Functions

The function has to be set before connecting the relay to the supply voltage.

E	ON delay
R	OFF delay
Ws	Single shot leading edge with control input
Wa	Single shot trailing edge with control input
Es	ON delay with control input
Wu	Single shot leading edge voltage controlled
Bp	Flasher pause first

Function sets of the distinct types are according to table ordering information or printing on the unit.

2. Time ranges

Time range	Adjustment range	
1s	50ms	1s
10s	500ms	10s
1min	3s	1min
10min	30s	10min
1h	3min	1h
10h	30min	10h
100h	5h	100h

3. Indicators

Green LED U/t ON:	indication of supply voltage
Green LED U/t flashes:	indication of time period
Yellow LED R ON/OFF:	indication of relay output

4. Mechanical design

Self-extinguishing plastic housing, IP rating IP40
 Mounted on DIN-rail TS 35 according to EN 60715
 Mounting position: any
 Shockproof terminal connection according to VBG 4 (PZ1 required), IP rating IP20
 Tightening torque: max. 1Nm
 Terminal capacity:

1 x 0.5 to 2.5mm ²	with/without multicore cable end
1 x 4mm ²	without multicore cable end
2 x 0.5 to 1.5mm ²	with/without multicore cable end
2 x 2.5mm ²	flexible without multicore cable end

5. Input circuit

Supply voltage:	terminals A1(+)-A2
E1Z... 12-240VAC/DC:	12 to 240V a.c./d.c.
Tolerance:	12V -10% to 240V +10%
E1Z... 24-240VAC/DC:	24 to 240V a.c./d.c.
Tolerance:	24V -15% to 240V +10%
Rated consumption:	4VA (1.5W)
Rated frequency:	a.c. 48 to 63Hz
Duty cycle:	100%
Reset time:	100ms
Residual ripple for d.c.:	10%
Drop-out voltage:	>30% of minimum rated supply voltage
Oversoltage category:	III (in accordance with IEC 60664-1)
Rated surge voltage:	4kV

6. Output circuit

1 potential free change over contact	
Contact material:	AgNi
Rated voltage:	250V a.c.
Switching capacity:	2000VA (8A / 250V a.c.)
Fusing:	8A fast acting
Mechanical life:	20 x 10 ⁶ operations
Electrical life:	2 x 10 ⁵ operations at 1000VA resistive load
Switching frequency:	max. 6/min at 1000VA resistive load (in accordance with IEC 60947-5-1)
Oversoltage category:	III (in accordance with IEC 60664-1)
Rated surge voltage:	4kV

7. Control input

Input not potential free:	terminals A1-B1
Loadable:	yes
Max. line length:	10m
Trigger level (sensitivity):	automatic adaption to supply voltage
Min. control pulse length:	d.c. 50ms / a.c. 100ms

8. General data

Degree of protection:	Basic insulation
Insulation test voltage:	
Supply circuit - Output circuit: 1680V	
Interference immunity:	Class A
Prospective current value:	1000A / 8A

8. Accuracy

Base accuracy:	±1% of maximum scale value
Adjustment accuracy:	<5% of maximum scale value
Repetition accuracy:	<0.5% or ±5ms
Voltage influence:	-
Temperature influence:	≤0.01% / °C

9. Ambient conditions

Ambient temperature:	-25 to +55°C
Storage temperature:	-25 to +70°C
Transport temperature:	-25 to +70°C
Relative humidity:	15% to 85% (in accordance with IEC 60721-3-3 class 3K3)
Pollution degree:	2 (in accordance with IEC 60664-1)

10. Weight

Single packing:	72g
Package 10pcs:	670g per Package

Functions

ON delay (E)

When the supply voltage U is applied, the set interval t begins (green LED U/t flashes). After the interval t has expired (green LED U/t illuminated) the output relay R switches into on-position (yellow LED illuminated). This status remains until the supply voltage is interrupted. If the supply voltage is interrupted before the expiry of the interval t, the interval already expired is erased and is restarted when the supply voltage is next applied.



OFF delay (R)

The supply voltage U must be constantly applied to the device (green LED U/t illuminated). When the control contact S is closed, the output relay R switches into on-position (yellow LED illuminated). If the control contact is opened, the set interval t begins (green LED flashes). After the interval t has expired (green LED U/t illuminated) the output relay switches into off-position (yellow LED not illuminated). If the control contact is closed again before the interval t has expired, the interval already expired is erased and is restarted.

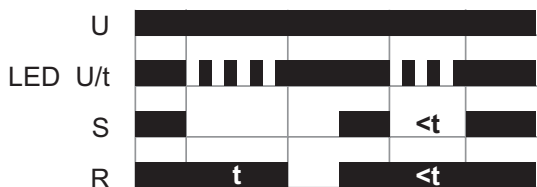

Single shot leading edge with control input (Ws)

The supply voltage U must be constantly applied to the device (green LED U/t illuminated). When the control contact S is closed, the output relay R switches into on-position (green LED U/t illuminated) and the set interval t begins (green LED U/t flashes). After the interval t has expired (green LED U/t illuminated) the output relay switches into off-position (yellow LED not illuminated). During the interval, the control contact can be operated any number of times. A further cycle can only be started when the cycle run has been completed.

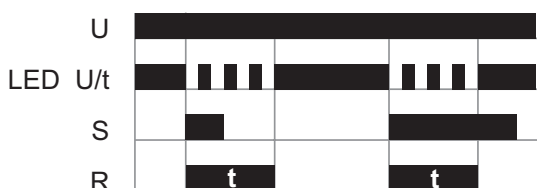

Single shot trailing edge with control input (Wa)

The supply voltage U must be constantly applied to the device (green LED U/t illuminated). Closing the control contact S has no influence on the condition of the output R. When the control contact is opened, the output relay switches into on-position (yellow LED illuminated) and the set interval t begins (green LED U/t flashes). After the interval t has expired (green LED U/t illuminated), the output relay switches into off-position (yellow LED not illuminated). During the interval, the control contact can be operated any number of times. A further cycle can only be started when the cycle run has been completed.

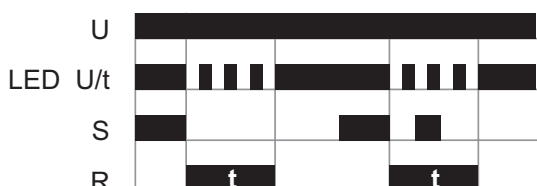

ON delay with control input (Es)

The supply voltage U must be constantly applied to the device (green LED U/t illuminated). When the control contact S is closed, the set interval t begins (green LED U/t flashes). After the interval t has expired (green LED U/t illuminated) the output relay R switches into on-position (yellow LED illuminated). This status remains until the control contact is opened again. If the control contact is opened before the interval t has expired, the interval already expired is erased and is restarted with the next cycle.

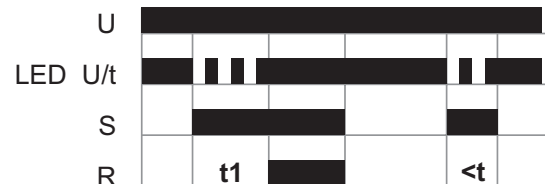

Single shot leading edge voltage controlled (Wu)

When the supply voltage U is applied, the output relay R switches into on-position (yellow LED illuminated) and the set interval t begins (green LED U/t flashes). After the interval t has expired (green LED U/t illuminated) the output relay switches into off-position (yellow LED not illuminated). This status remains until the supply voltage is interrupted. If the supply voltage is interrupted before the interval t has expired, the output relay switches into off-position. The interval already is erased and is restarted when the supply voltage is next applied.



Flasher pause first (Bp)

When the supply voltage U is applied, the set interval t begins (green LED U/t flashes). After the interval t has expired, the output relay R switches into on-position (yellow LED illuminated) and the set interval t begins again. After the interval t has expired, the output relay switches into off-position (yellow LED not illuminated). The output relay is triggered at a ratio of 1:1 until the supply voltage is interrupted.



Connections

Dimensions

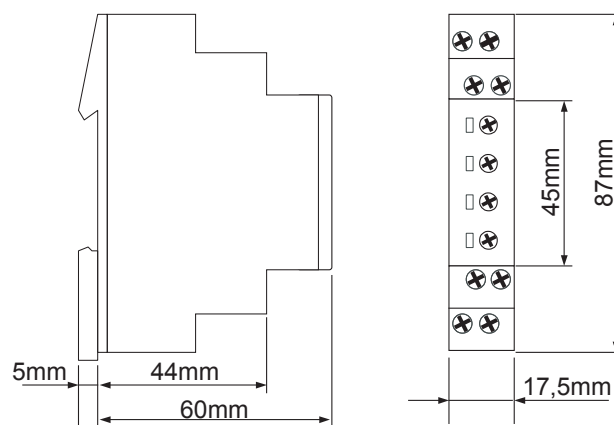
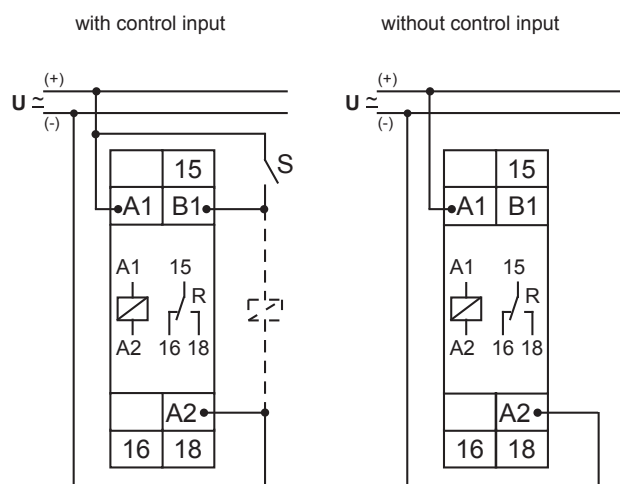

Ordering information

Type	Functions	Supply voltage	Art. No. (PQ 1)	Art. No. (PQ 10)
E1ZM10 12-240V AC/DC	E, R,Ws, Wa, Es, Wu, Bp	12-240V a.c./d.c.	110100	110100A
E1ZM10 24-240V AC/DC	E, R,Ws, Wa, Es, Wu, Bp	24-240V a.c./d.c.	110200	110200A
E1ZMQ10 24-240V AC/DC	E, R, Wu, Bp	24-240V a.c./d.c.	110202	110202A
E1Z1E10 24-240V AC/DC	E	24-240V a.c./d.c.		110204A
E1Z1R10 24-240V AC/DC	R	24-240V a.c./d.c.		110205A

ENYA series

2-time delay, on-delay and off-delay

7 time ranges

Wide input voltage range

1 change over contact

Width 17.5 mm

Installation design



Technical data

1. Functions

ER ON delay and OFF delay with control contact

2. Time ranges

Time range	Adjustment range	
1s	50ms	1s
10s	500ms	10s
1min	3s	1min
10min	30s	10min
1h	3min	1h
10h	30min	10h
100h	5h	100h

3. Indicators

Green LED U/t ON:	indication of supply voltage
Green LED U/t slow flashing:	indication of time period t1
Green LED U/t fast flashing:	indication of time period t2
Yellow LED ON/OFF:	indication of relay output

4. Mechanical design

Self-extinguishing plastic housing, IP rating IP40
 Mounted on DIN-rail TS 35 according to EN 60715
 Mounting position: any
 Shockproof terminal connection according to VBG 4 (PZ1 required),
 IP rating IP20
 Tightening torque: max. 1Nm
 Terminal capacity:
 1 x 0.5 to 2.5mm² with/without multicore cable end
 1 x 4mm² without multicore cable end
 2 x 0.5 to 1.5mm² with/without multicore cable end
 2 x 2.5mm² flexible without multicore cable end

5. Input circuit

Supply voltage:	24 to 240V a.c./d.c terminals A1(+)-A2
Tolerance:	-15% to +10%
Rated consumption:	6VA (1.5W)
Rated frequency:	a.c. 48 to 63Hz
Duty cycle:	100%
Reset time:	100ms
Residual ripple for d.c.:	10%
Drop-out voltage:	>30% of minimum rated supply voltage
Oversvoltage category:	III (in accordance with IEC 60664-1)
Rated surge voltage:	4kV

6. Output circuit

1 potential free change over	
Rated voltage:	250V a.c.
Switching capacity:	2000VA (8A / 250V a.c.)
Fusing:	8A fast acting
Mechanical life:	20 x 10 ⁶ operations
Electrical life:	2 x 10 ⁵ operations at 1000VA resistive load
Switching frequency:	max. 6/min at 1000VA resistive load (in accordance with IEC 60947-5-1)
Oversvoltage category:	III (in accordance with IEC 60664-1)
Rated surge voltage:	4kV

7. Control input

Input not potential free:	terminals A1-B1
Loadable:	yes
Max. line length:	10m
Trigger level (sensitivity):	automatic adaption to supply voltage
Min. control pulse length:	d.c. 50ms / a.c. 100ms

8. Accuracy

Base accuracy:	±1% of maximum scale value
Adjustment accuracy:	<5% of maximum scale value
Repetition accuracy:	<0.5% or ±5ms
Voltage influence:	-
Temperature influence:	≤0.01% / °C

9. Ambient conditions

Ambient temperature:	-25 to +55°C
Storage temperature:	-25 to +70°C
Transport temperature:	-25 to +70°C
Relative humidity:	15% to 85% (in accordance with IEC 60721-3-3 class 3K3)
Pollution degree:	2 (in accordance with IEC 60664-1)

10. Weight

Package 10 pcs:	670g per Package
-----------------	------------------

Functions

ON delay and OFF delay with control contact (ER)

The supply voltage U must be constantly applied to the device (green LED U/t illuminated). When the control contact S is closed, the set interval t1 begins (green LED U/t flashes slowly). After the interval t1 has expired, the output relay R switches into on-position (yellow LED illuminated). If the control contact is opened, the set interval t2 begins (green LED U/t flashes fast). After the interval t2 has expired, the output relay switches into off-position (yellow LED not illuminated). If the control contact is opened before the interval t1 has expired, the interval already expired is erased and is restarted with the next cycle.

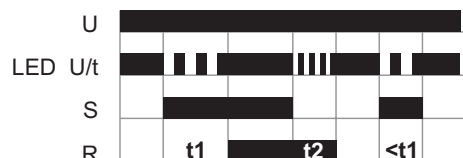

Dimensions

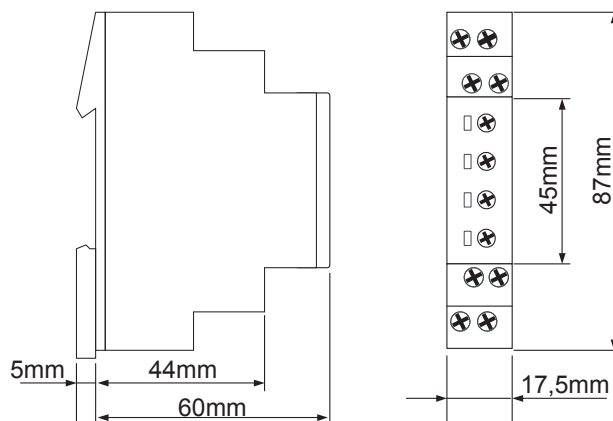

Connection

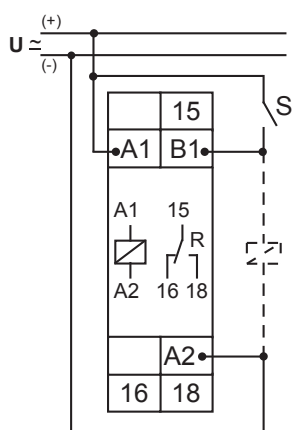

Ordering information

Type	Functions	Supply voltage	Art. No. (PQ 1)	Art. No. (PQ 10)
E1Z1ER10 24-240V AC/DC	ER	24-240V a.c./d.c	-	110208A



ENYA series
7 time ranges
Wide input voltage range
1 change over contact
Width 17.5 mm
Installation design



Technical data

1. Functions

Ip Asymmetric flasher pause first
li Asymmetric flasher pulse first
(A1-B1 bridged)

2. Time ranges

Time range	Adjustment range	
1s	50ms	1s
10s	500ms	10s
1min	3s	1min
10min	30s	10min
1h	3min	1h
10h	30min	10h
100h	5h	100h

3. Indicators

Green LED U/t ON: indication of supply voltage
Green LED U/t slow flashing: indication of time period t1
Green LED U/t fast flashing: indication of time period t2
Yellow LED R ON/OFF: indication of relay output

4. Mechanical design

Self-extinguishing plastic housing, IP rating IP40
Mounted on DIN-rail TS 35 according to EN 60715
Mounting position: any
Shockproof terminal connecting according to VBG 4 (PZ1 required),
IP rating IP20
Tightening torque: max. 1Nm
Terminal capacity:
1 x 0.5 to 2.5mm² with /without multicore cable end
1 x 4mm² without multicore cable end
2 x 0.5 to 1.5mm² with/without multicore cable end
2 x 2.5mm² flexible without multicore cable end

5. Input circuit

Supply voltage: terminals A1(+)-A2
12 to 240V AC/DC
Tolerance: -10% to +10%
Rated consumption: 4VA (1.5W)
Rated frequency: AC 48 to 63Hz
Duty cycle: 100%
Reset time: 100ms
Residual ripple to DC: 10%
Drop-out voltage: >30% of the supply voltage
Overvoltage category: III (in accordance with IEC 60664-1)
Rated surge voltage: 4kV

6. Output circuit

1 potential free change over contact
Rated voltage: 250V AC
Switching capacity: 2000VA (8A / 250V)
Fusing: 8A fast acting
Mechanical life: 20 x 10⁶ operations
Electrical life: 2 x 10⁶ operations
at 1000VA resistive load
Switching frequency: max. 6/min at 1000VA resistive load
(in accordance with IEC 60947-5-1)
Overvoltage category: III (in accordance with IEC 60664-1)
Rated surge voltage: 4kV

7. Control input

Input not potential free: terminals A1-B1
Loadable: yes
Max. line length: 10m
Trigger level (sensitivity): automatic adaption to supply voltage

8. Accuracy

Base accuracy: ±1% maximum scale value
Adjustment accuracy: <5% maximum scale value
Repetition accuracy: <0.5% or ±5ms
Voltage influence: -
Temperature influence: ≤0.01% / °C

9. Ambient conditions

Ambient temperature: -25 to +55°C
Storage temperature: -25 to +70°C
Transport temperature: -25 to +70°C
Relative humidity: 15% to 85%
(in accordance with IEC 60721-3-3 class 3K3)
Pollution degree: 2, if built-in 3
(in accordance with IEC 60664-1)

10. Weight

Single packing: 72g
Package 10pcs: 670g per Package

Functions

Asymmetric flasher pause first (Ip)

When the supply voltage U is applied, the set interval t1 begins (green LED U/t flashes slowly). After the interval t1 has expired, the output relay R switches into on-position (yellow LED illuminated) and the set interval t2 begins (green LED U/t flashes fast). After the interval t2 has expired, the output relay switches into off-position (yellow LED not illuminated).

The output relay is triggered at the ratio of t1:t2 until the supply voltage is interrupted.

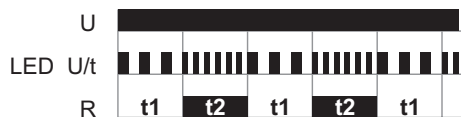

Asymmetric flasher pulse first (Ii)

When the supply voltage U is applied, the output relay R switches into on-position (yellow LED illuminated) and the set interval t1 begins (green LED U/t flashes slowly). After the interval t1 has expired, the output relay switches into off-position (yellow LED not illuminated) and the set interval t2 begins (green LED U/t flashes fast). After the interval t2 has expired, the output relay switches into on-position (yellow LED illuminated).

The output relay is triggered at the ratio of t1:t2 until the supply voltage is interrupted.



Connections

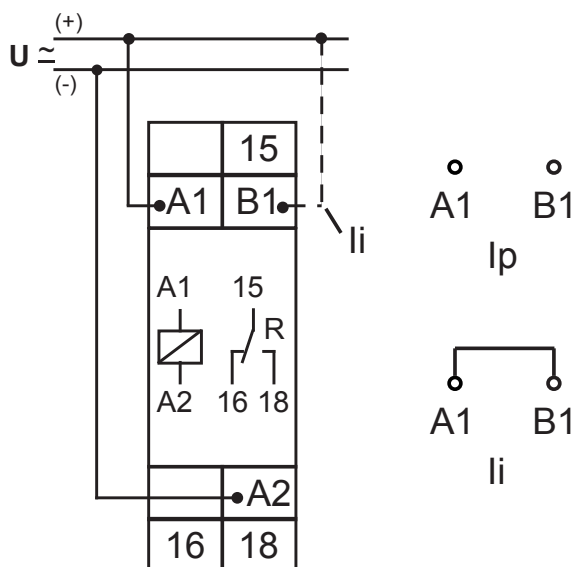

Dimensions

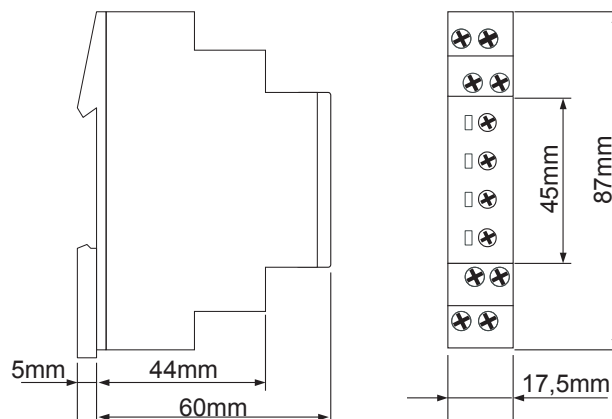



- ENYA series
- Up to 7 functions
- 7 time ranges
- Wide input range
- 1 change over contact
- Width 17.5mm
- Installation design



Technical data

1. Functions

The function has to be set before connecting the relay to the supply voltage.

E	ON delay
R	OFF delay
Ws	Single shot leading edge with control input
Wa	Single shot trailing edge with control input
WsWa	Single shot leading edge and single shot trailing edge with control input
Wu	Single shot leading edge voltage controlled
Wt	Pulse sequence monitoring

2. Time ranges

Time range	Adjustment range	
1s	50ms	1s
10s	500ms	10s
1min	3s	1min
10min	30s	10min
1h	3min	1h
10h	30min	10h
100h	5h	100h

3. Indicators

Green LED U/t ON:	indication of supply voltage
Green LED U/t flashes:	indication of time period
Yellow LED R ON/OFF:	indication of relay output

4. Mechanical design

Self-extinguishing plastic housing, IP rating IP40
 Mounted on DIN-rail TS 35 according to EN 50022
 Mounting position: any
 Shockproof terminal connection according to VBG 4 (PZ1 required),
 IP rating IP20
 Tightening torque: max. 1Nm
 Terminal capacity:
 1 x 0.5 to 2.5mm² with/without multicore cable end
 1 x 4mm² without multicore cable end
 2 x 0.5 to 1.5mm² with/without multicore cable end
 2 x 2.5mm² flexible without multicore cable end

5. Input circuit

Supply voltage:	24 to 240V AC/DC
Terminals:	A1(+)-A2
Tolerance:	-15% to +10%
Rated consumption:	4VA (1.5W)
Rated frequency:	AC 48 to 63Hz
Duration of operation:	100%
Reset time:	100ms
Residual ripple of DC:	10%
Drop-out voltage:	>30% of minimum rated supply voltage
Overvoltage category:	III (in accordance with IEC 60664-1)
Rated surge voltage:	4kV

6. Output circuit

1 potential free change over contact	
Rated voltage:	250V AC
Switching capacity:	2000VA (8A / 250V)
Fusing:	8A fast acting
Mechanical life:	20 x 10 ⁶ operations
Electrical life:	2 x 10 ⁵ operations at 1000VA resistive load
Switching frequency:	max. 6/min at 1000VA resistive load (in accordance with IEC 60947-5-1)
Overvoltage category:	III. (in accordance with IEC 60664-1)
Rated surge voltage:	4kV

7. Control input

Input not potential free:	terminals A1-B1
Loadable:	yes
Max. line length:	10m
Trigger level (sensitivity):	automatic adaption to supply voltage
Min. control pulse length:	DC 50 ms / AC 100 ms

8. Accuracy

Base accuracy:	±1% of maximum scale value
Adjustment accuracy:	<5% of maximum scale value
Repetition accuracy:	<0.5% or ±5ms
Voltage influence:	-
Temperature influence:	≤0.01% / °C

9. Ambient conditions

Ambient temperature:	-25 to +55°C
Storage temperature:	-25 to +70°C
Transport temperature:	-25 to +70°C
Relative humidity:	15% to 85% (in accordance with IEC 60721-3-3 class 3K3)
Pollution degree:	2, if built in 3 (in accordance with IEC 60664-1)

10. Weight

Single packing:	72g
Package 10pcs:	670g per Package

Functions

ON delay (E)

When the supply voltage U is applied, the set interval t begins (green LED U/t flashes). After the interval t has expired (green LED U/t illuminated) the output relay R switches into on-position (yellow LED illuminated). This status remains until the supply voltage is interrupted. If the supply voltage is interrupted before the expiry of the interval t, the interval already expired is erased and is restarted when the supply voltage is next applied.



OFF delay (R)

The supply voltage U must be constantly applied to the device (green LED U/t illuminated). When the control contact S is closed, the output relay R switches into on-position (yellow LED illuminated). If the control contact S is opened, the set interval t begins (green LED U/t flashes). After the interval t has expired (green LED U/t illuminated) the output relay R switches into off-position (yellow LED not illuminated). If the control contact S is closed again before the interval t has expired, the interval already expired is erased and is restarted.

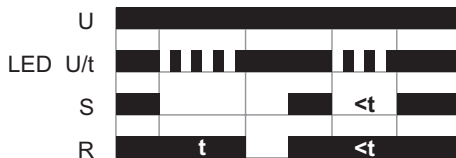

Single shot leading edge with control input (Ws)

The supply voltage U must be constantly applied to the device (green LED U/t illuminated). When the control contact S is closed, the output relay R switches into on-position (yellow LED illuminated) and the set interval t begins (green LED U/t flashes). After the interval t has expired (green LED U/t illuminated) the output relay R switches into off-position (yellow LED not illuminated). During the interval, the control contact can be operated any number of times. A further cycle can only be started when the cycle run has been completed.

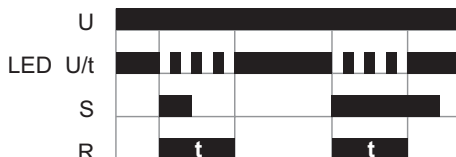

Single shot trailing edge with control input (Wa)

The supply voltage U must be constantly applied to the device (green LED U/t illuminated). Closing the control contact S has no influence on the condition of the output R. When the control contact S is opened, the output relay R switches into on-position (yellow LED illuminated) and the set interval t begins (green LED U/t flashes). After the interval t has expired (green LED U/t illuminated), the output relay R switches into off-position (yellow LED not illuminated). During the interval, the control contact S can be operated any number of times. A further cycle can only be started when the cycle run has been completed.

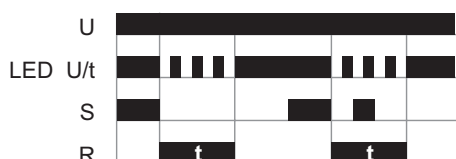

Single shot leading and single shot trailing edge with control input (WsWa)

The supply voltage U must be constantly applied to the device (green LED U/t illuminated). When the control contact S is closed, the output relay R switches into on-position (yellow LED illuminated) and the set interval t begins (green LED U/t flashes). After the interval t has expired, the output relay R switches into off-position (yellow LED not illuminated). If the control contact S is opened, the output relay R switches into on-position again (yellow LED illuminated) and the set interval t begins (green LED U/t flashes). After the interval t has expired the output relay R switches into off-position (yellow LED not illuminated). During the interval, the control contact S can be operated any number of times.

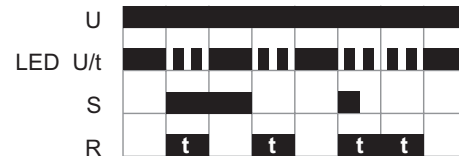

Single shot leading edge voltage controlled (Wu)

When the supply voltage U is applied, the output relay R switches into on-position (yellow LED illuminated) and the set interval t begins (green LED U/t flashes). After the interval t has expired (green LED U/t illuminated) the output relay R switches into off-position (yellow LED not illuminated). This status remains until the supply voltage is interrupted. If the supply voltage is interrupted before the interval t has expired, the output relay R switches into off-position. The interval already is erased and is restarted when the supply voltage is next applied.



Pulse sequence monitoring (Wt)

When the supply voltage U is applied (green LED U/t illuminated), the output relay R switches into on-position (yellow LED illuminated). When the control contact S is closed, the set interval t begins (green LED U/t flashes). So that the output relay R remains in on-position, the control contact S must be opened and closed again within the set interval t. If this does not happen, the output relay R switches into off-position and all further pulses at the control contact are ignored. To restart the function the supply voltage must be interrupted and re-applied.



Connections

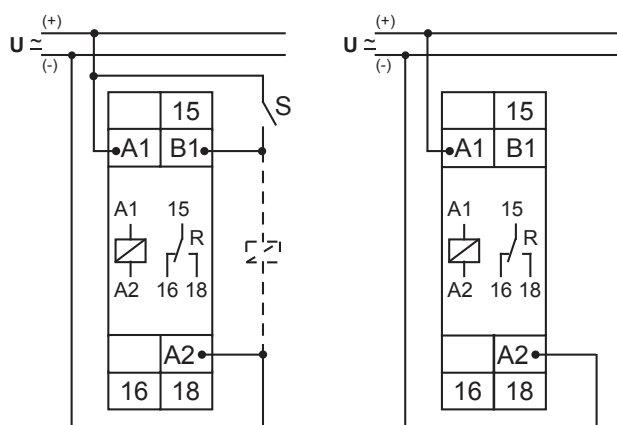

Dimensions

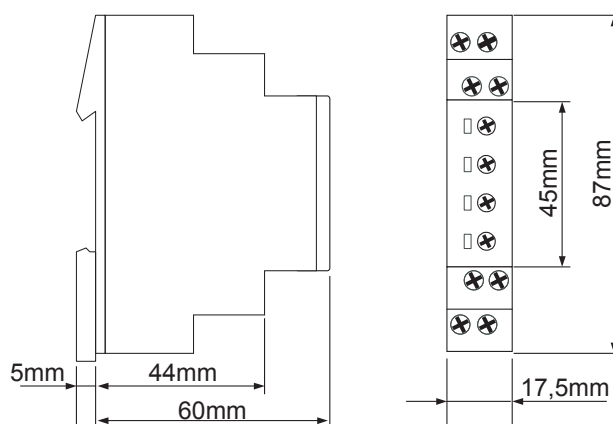

Ordering information

Types	Functions	Supply voltage	Part Nr. (PQ 1)	Part Nr. (PQ 10)
E1ZMW10 24-240V AC/DC	E, R, Ws, Wa, WsWa, Wu, Wt	24-240V AC/DC	-	110206A

Timers - Multifunctional

E1ZMWt10

Part No. 110217

ENYA series
 7 functions
 7 time ranges
 Wide input range
 1 change over contact
 Width 17.5mm
 Installation design



Technical data

1. Functions

The function has to be set before connecting the relay to the supply voltage.

E	ON delay
R	OFF delay
Ws	Single shot leading edge with control input
Wa	Single shot trailing edge with control input
Wtf	Pulse sequence monitoring edge triggered
Wto	Pulse sequence monitoring edge triggered with on state
Wt	Pulse sequence monitoring

2. Time ranges

Time range	Adjustment range	
1s	50ms	1s
10s	500ms	10s
1min	3s	1min
10min	30s	10min
1h	3min	1h
10h	30min	10h
100h	5h	100h

3. Indicators

Green LED U/t ON:	indication of supply voltage
Green LED U/t flashes:	indication of time period
Yellow LED R ON/OFF:	indication of relay output

4. Mechanical design

Self-extinguishing plastic housing, IP rating IP40
 Mounted on DIN-rail TS 35 according to EN 50022
 Mounting position: any
 Shockproof terminal connection according to VBG 4 (PZ1 required), IP rating IP20
 Tightening torque: max. 1Nm
 Terminal capacity:
 1 x 0.5 to 2.5mm² with/without multicore cable end
 1 x 4mm² without multicore cable end
 2 x 0.5 to 1.5mm² with/without multicore cable end
 2 x 2.5mm² flexible without multicore cable end

5. Input circuit

Supply voltage:	24 to 240V AC/DC
Terminals:	A1(+)-A2
Tolerance:	-15% to +10%
Rated consumption:	4VA (1.5W)
Rated frequency:	AC 48 to 63Hz
Duration of operation:	100%
Reset time:	100ms
Residual ripple of DC:	10%
Drop-out voltage:	>30% of minimum rated supply voltage
Overvoltage category:	III (in accordance with IEC 60664-1)
Rated surge voltage:	4kV

6. Output circuit

1 potential free change over contact	
Rated voltage:	250V AC
Switching capacity:	2000VA (8A / 250V)
Fusing:	8A fast acting
Mechanical life:	20 x 10 ⁵ operations
Electrical life:	2 x 10 ⁵ operations at 1000VA resistive load
Switching frequency:	max. 6/min at 1000VA resistive load (in accordance with IEC 60947-5-1)
Overvoltage category:	III. (in accordance with IEC 60664-1)
Rated surge voltage:	4kV

7. Control input

Input not potential free:	terminals A1-B1
Loadable:	yes
Max. line length:	10m
Trigger level (sensitivity):	automatic adaption to supply voltage
Min. control pulse length:	DC 50 ms / AC 100 ms

8. Accuracy

Base accuracy:	±1% of maximum scale value
Adjustment accuracy:	<5% of maximum scale value
Repetition accuracy:	<0.5% or ±5ms
Voltage influence:	-
Temperature influence:	≤0.01% / °C

9. Ambient conditions

Ambient temperature:	-25 to +55°C
Storage temperature:	-25 to +70°C
Transport temperature:	-25 to +70°C
Relative humidity:	15% to 85% (in accordance with IEC 60721-3-3 class 3K3)
Pollution degree:	2, if built in 3 (in accordance with IEC 60664-1)

10. Weight

Single packing:	72g
-----------------	-----

Functions

ON delay (E)

When the supply voltage U is applied, the set interval t begins (green LED U/t flashes). After the interval t has expired (green LED U/t illuminated) the output relay R switches into on-position (yellow LED illuminated). This status remains until the supply voltage is interrupted.

If the supply voltage is interrupted before the expiry of the interval t, the interval already expired is erased and is restarted when the supply voltage is next applied.



OFF delay (R)

The supply voltage U must be constantly applied to the device (green LED U/t illuminated). When the control contact S is closed, the output relay R switches into on-position (yellow LED illuminated). If the control contact S is opened, the set interval t begins (green LED flashes). After the interval t has expired (green LED U/t illuminated) the output relay R switches into off-position (yellow LED not illuminated). If the control contact S is closed again before the interval t has expired, the interval already expired is erased and is restarted.

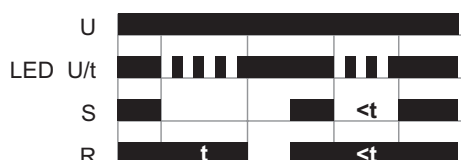

Single shot leading edge with control input (Ws)

The supply voltage U must be constantly applied to the device (green LED U/t illuminated). When the control contact S is closed, the output relay R switches into on-position (green LED U/t illuminated) and the set interval t begins (green LED U/t flashes). After the interval t has expired (green LED U/t illuminated) the output relay R switches into off-position (yellow LED not illuminated). During the interval, the control contact can be operated any number of times. A further cycle can only be started when the cycle run has been completed.

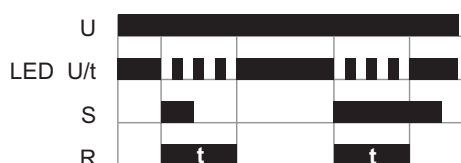

Single shot trailing edge with control input (Wa)

The supply voltage U must be constantly applied to the device (green LED U/t illuminated). Closing the control contact S has no influence on the condition of the output R. When the control contact S is opened, the output relay R switches into on-position (yellow LED illuminated) and the set interval t begins (green LED U/t flashes). After the interval t has expired (green LED U/t illuminated), the output relay R switches into off-position (yellow LED not illuminated). During the interval, the control contact S can be operated any number of times. A further cycle can only be started when the cycle run has been completed.

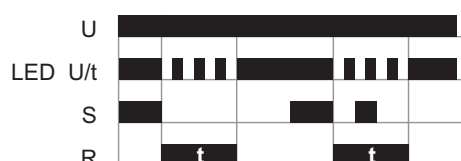

Pulse sequence monitoring edge triggered (Wtf)

When the supply voltage U is applied the green LED U/t illuminated. When the control contact S is closed (rising edge) the output relay R switches into on-position (yellow LED illuminated) and the set interval t begins (green LED U/t flashes). So that the output relay R remains in on-position, the control contact S must be opened and closed again within the set interval t. If this does not happen, the output relay R switches into off-position. If a new positive edge on the control input is detected, the interval t begins (green LED U/t flashes) and the output relay R switches into on-position (yellow LED illuminated).

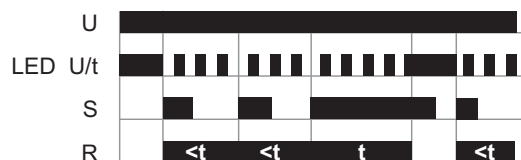

Pulse sequence monitoring edge triggered with on state (Wto)

When the supply voltage U is applied the green LED U/t illuminated and if the control input S ist on at the same time the set interval t begins (green LED U/t flashes) and the output relay R switches into on-position (yellow LED illuminated). If there is no rising edge detected on the control input S, then the Relay R switches into off state. When the control contact S is closed (rising edge) again the output relay R switches into on-position (yellow LED illuminated) and the set interval t begins (green LED U/t flashes). So that the output relay R remains in on-position, the control contact S must be opened and closed again within the set interval t. If this does not happen, the output relay R switches into off-position. If a new positive edge on the control input is detected, the interval t begins (green LED U/t flashes) and the output relay R switches into on-position (yellow LED illuminated).

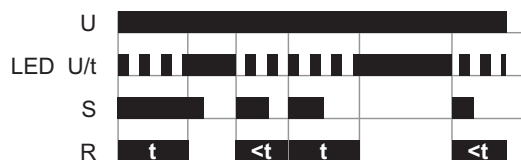

Pulse sequence monitoring (Wt)

When the supply voltage U is applied (green LED U/t illuminated), the output relay R switches into on-position (yellow LED illuminated). When the control contact S is closed, the set interval t begins (green LED U/t flashes). So that the output relay R remains in on-position, the control contact S must be opened and closed again within the set interval t. If this does not happen, the output relay R switches into off-position and all further pulses at the control contact are ignored. To restart the function the supply voltage must be interrupted and re-applied.

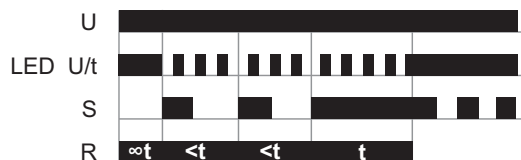

Connections

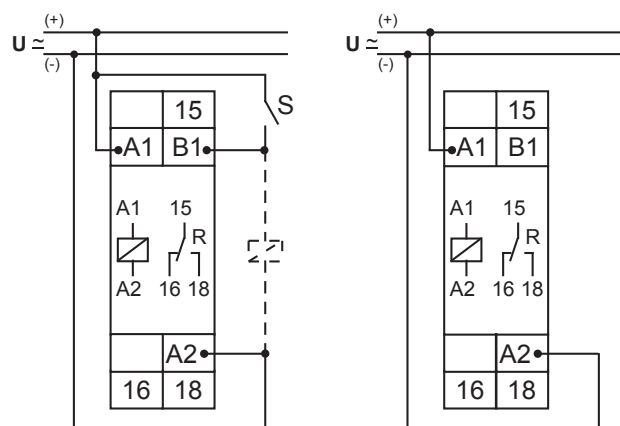

Dimensions

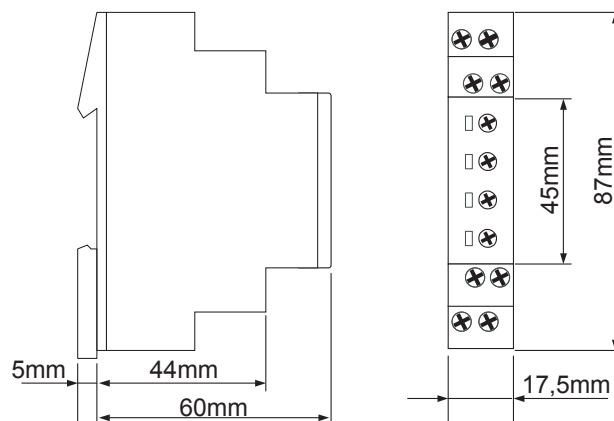

Ordering information

Types	Functions	Supply voltage	Part Nr. (PQ 1)
E1ZMWt10 24-240V AC/DC	E, R, Ws, Wa, Wtf, Wto, Wt	24-240V AC/DC	110217



series ENYA

2-time multifunction

7 time ranges

Wide input voltage range

2 change-over contacts

Width 35mm

Installation design



Technical data

1. Functions

The function has to be set before connecting the relay to the supply voltage.

Ip	Asymmetric flasher pause first
li	Asymmetric flasher pulse first
ER	ON delay and OFF delay with control contact
EWu	ON delay single shot leading edge voltage controlled
EWs	ON delay single shot leading edge with control contact
WsWa	Single shot leading and single shot trailing edge with control contact
Wt	Pulse sequence monitoring

2. Time ranges

Time range	Adjustment range	
1s	50ms	1s
10s	500ms	10s
1min	3s	1min
10min	30s	10min
1h	3min	1h
10h	30min	10h
100h	5h	100h

3. Indicators

Green LED U/t ON:	indication of supply voltage
Green LED U/t slow flashing:	indication of time period t1
Green LED U/t fast flashing:	indication of time period t2
Yellow LED ON/OFF:	indication of relay output

4. Mechanical design

Self-extinguishing plastic housing, IP rating IP40
 Mounted on DIN-Rail TS 35 according to EN 60715
 Mounting position: any
 Shockproof terminal connection according to VBG 4 (PZ1 required), IP rating IP20
 Tightening torque: max. 1Nm
 Terminal capacity:
 1 x 0.5 to 2.5mm² with/without multicore cable end
 1 x 4mm² without multicore cable end
 2 x 0.5 to 1.5mm² with/without multicore cable end
 2 x 2.5mm² flexible without multicore cable end

5. Input circuit

Supply voltage:	12 to 240V a.c./d.c.
Terminals:	A1(+)- A2
Tolerance:	-10% to +10%
Rated frequency:	48 to 63Hz
Rated consumption:	6VA (2W)
Duration of operation:	100%
Reset time:	100ms
Residual ripple of d.c.:	-
Drop-out voltage:	>30% of supply voltage
Overvoltage category:	III (in accordance with IEC 60664-1)
Rated surge voltage:	4kV

6. Output circuit

2 potential free change over contacts	
Rated voltage:	250V a.c.
Switching capacity:	2000VA (8A / 250V)
Fusing:	8A fast acting
Mechanical life:	20 x 10 ⁶ operations
Electrical life:	2 x 10 ⁵ operations at 1000VA resistive load
Switching frequency:	max. 6/min at 1000VA resistive load (in accordance with IEC 60947-5-1)
Overvoltage category:	III (in accordance with IEC 60664-1)
Rated surge voltage:	4kV

7. Control input

Input not potential free:	terminals A1-B1
Loadable:	yes
Max. line length:	10m
Trigger level (sensitivity):	automatic adaption to supply voltage
Max. control pulse length:	d.c. 50ms / a.c. 100ms

8. Accuracy

Base accuracy:	±1% of maximum scale value
Adjusting accuracy:	≤5% of maximum scale value
Repetition accuracy:	<0.5% or ±5ms
Voltage influence:	-
Temperature influence:	≤0.01% / °C

9. Ambient conditions

Ambient temperature:	-25 to +55°C
Storage temperature:	-25 to +70°C
Transport temperature:	-25 to +70°C
Relative humidity:	15% to 85% (in accordance with IEC 60721-3-3 class 3K3)
Pollution degree:	2 (in accordance with IEC 60664-1)

10. Weight

Single packing:	106g
-----------------	------

Functions

Asymmetric flasher pause first (Ip)

When the supply voltage U is applied, the set interval t1 begins (green LED U/t flashes slowly). After the interval t1 has expired, the output relay R switches into on-position (yellow LED illuminated) and the set interval t2 begins (green LED U/t flashes fast). After the interval t2 has expired, the output relay switches into off-position (yellow LED not illuminated). The output relay is triggered at the ratio of t1:t2 until the supply voltage is interrupted.

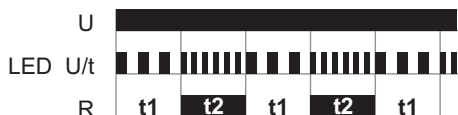

Asymmetric flasher pulse first (Ii)

When the supply voltage U is applied, the output relay R switches into on-position (yellow LED illuminated) and the set interval t1 begins (green LED U/t flashes slowly). After the interval t1 has expired, the output relay switches into off-position (yellow LED not illuminated) and the set interval t2 begins (green LED U/t flashes fast). After the interval t2 has expired, the output relay switches into on-position (yellow LED illuminated). The output relay is triggered at the ratio of t1:t2 until the supply voltage is interrupted.

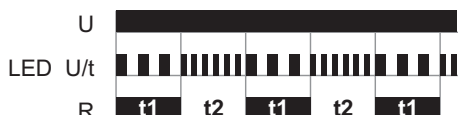

ON delay and OFF delay with control contact (ER)

The supply voltage U must be constantly applied to the device (green LED U/t illuminated). When the control contact S is closed, the set interval t1 begins (green LED U/t flashes slowly). After the interval t1 has expired, the output relay R switches into on-position (yellow LED illuminated). If the control contact is opened, the set interval t2 begins (green LED U/t flashes fast). After the interval t2 has expired, the output relay switches into off-position (yellow LED not illuminated). If the control contact is opened before the interval t1 has expired, the interval already expired is erased and is restarted with the next cycle.

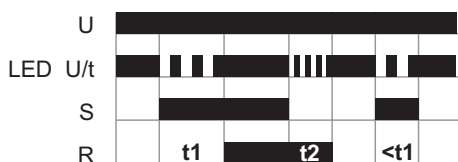

ON delay and single shot leading edge voltage controlled (EWu)

When the supply voltage U is applied, the set interval t1 begins (green LED U/t flashes slowly). After the interval t1 has expired, the output relay R switches into on-position (yellow LED illuminated) and the set interval t2 begins (green LED U/t flashes fast). After the interval t2 has expired, the output relay switches into off-position (yellow LED not illuminated). If the supply voltage is interrupted before the interval t1+t2 has expired, the interval already expired is erased and is restarted when the supply voltage is next applied.



ON delay and single shot leading edge with control contact (EWs)

The supply voltage U must be constantly applied to the device (green LED U/t illuminated). When the control contact S is closed, the set interval t1 begins (green LED U/t flashes slowly). After the interval t1 has expired, the output relay R switches into on-position (yellow LED illuminated) and the set interval t2 begins (green LED U/t flashes fast). After the interval t2 has expired, the output relay switches into off-position (yellow LED not illuminated). During the interval, the control contact can be operated any number of times. A further cycle can only be started when the cycle run has been completed.

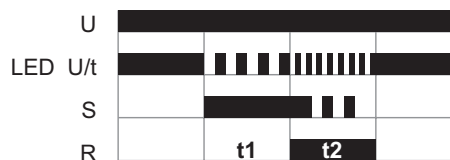

Single shot leading and single shot trailing edge with control contact (WsWa)

The supply voltage U is constantly applied to the device (green LED U/t illuminated). When the control contact S is closed, the output relay R switches into on-position (yellow LED illuminated) and the set interval t1 begins (green LED U/t flashes slowly). After the interval t1 has expired, the output relay R switches into off-position (yellow LED not illuminated). If the control contact is opened, the output relay again switches into on-position (yellow LED illuminated) and the set interval t2 begins (green LED U/t flashes fast). After the interval t2 has expired the output relay switches into off-position (yellow LED not illuminated). During the interval, the control contact can be operated any number of times.

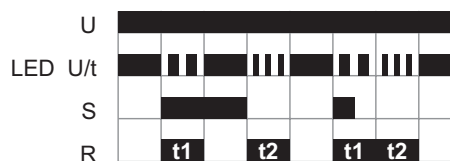

Pulse sequence monitoring (Wt)

When the supply voltage U is applied, the set interval t1 begins (green LED U/t flashes slowly) and the output relay R switches into on-position (yellow LED illuminated). After the interval t1 has expired, the set interval t2 begins (green LED U/t flashes fast). So that the output relay R remains in on-position, the control contact S must be closed and opened again within the set interval t2. If this does not happen, the output relay R switches into off-position (yellow LED not illuminated) and all further pulses at the control contact are ignored. To restart the function the supply voltage must be interrupted and reapplied.

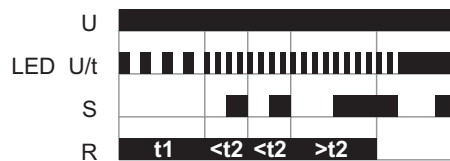

Connections

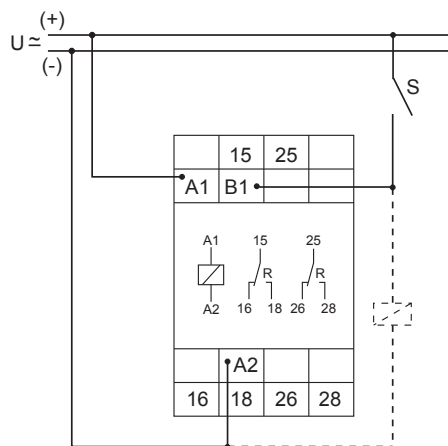

Dimensions

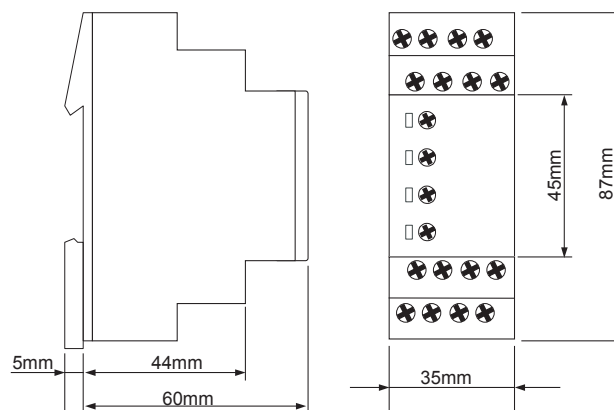

Ordering information

Type	Functions	Supply voltage	Part. No. (PQ 1)
E3ZI20 12-240V a.c./d.c.	lp, li, ER, EWu, WsWa, Wt	12-240V a.c./d.c.	111101



ENYA series

4 Time ranges (Start-up time)

Wide input range

2 change over contacts

Width 35mm

Installation design



Technical data

1. Functions

S Star-Delta start-up

2. Time ranges

Start-up time

Time range	Adjustment range	
10s	500ms	10s
30s	1500ms	30s
1min	3s	1min
3min	9s	3min

Transit time (fixed)

40ms
60ms
80ms
100ms

3. Indicators

Green LED U/t ON: indication of supply voltage delta-contactor in on-position (terminals 25-28)

Green LED U/t flashes: indication of time period - start-up time

Yellow LED ON/OFF: indication of star-conductor (terminals 15-18)

4. Mechanical design

Self-extinguishing plastic housing, IP rating IP40

Mounted on DIN-rail TS 35 according to EN 60715

Mounting position: any

Shockproof terminal connection according to VBG 4 (PZ1 required),

IP rating IP20

Tightening torque: max. 1Nm

Terminal capacity:

1 x 0.5 to 2.5mm² with/without multicore cable end
1 x 4mm² without multicore cable end
2 x 0.5 to 1.5mm² with/without multicore cable end
2 x 2.5mm² flexible without multicore cable end

5. Input circuit

Supply voltage: 12 to 240V AC/DC

Terminals: A1(+)-A2

Tolerance: -10% to +10%

Rated consumption: 4VA (1.5W)

Rated frequency: AC 48 to 63Hz

Duty cycle: 100%

Reset time: 100ms

Residual ripple to DC: 10%

Drop-out voltage: >30% of minimum rated supply voltage

Overshoot category: III (in accordance with IEC 60664-1)

Rated surge voltage: 4kV

6. Output circuit

2 potential free change over contacts

Rated voltage: 250V AC

Switching capacity: 2000VA (8A / 250V)

Fusing: 8A fast acting

Mechanical life: 20 x 10⁶ operations

Electrical life: 2 x 10⁵ operations at 1000VA resistive load

Switching frequency: max. 6/min at 1000VA resistive load

(in accordance with IEC 60947-5-1)

III (in accordance with IEC 60664-1)

Overshoot category:

Rated surge voltage: 4kV

7. Accuracy

Base accuracy: ±1% of minimum scale value

Adjustment accuracy: <5% of minimum scale value

Repetition accuracy: <0.5% or ±5ms

Voltage influence: -

Temperature influence: ≤0.01% / °C

8. Ambient conditions

Ambient temperature: -25 to +55°C

Storage temperature: -25 to +70°C

Transport temperature: -25 to +70°C

Relative humidity: 15% to 85%

(in accordance with IEC 60721-3-3 class 3K3)

Pollution degree: 2 (in accordance with IEC 60664-1)

9. Weight

Single packing: 106g

Functions

Star-Delta start-up

When the supply voltage U is applied, the star-contact switches into on-position (yellow LED illuminated) and the set star-time t_1 begins (green LED U/t flashes). After the interval t_1 has expired (green LED U/t illuminated) the star-contact switches into off-position (yellow LED not illuminated) and the set transit-time t_2 begins. After the interval t_2 has expired the contact for the delta-contactor switches into on-position. To restart the function the supply voltage must be interrupted and re-applied.

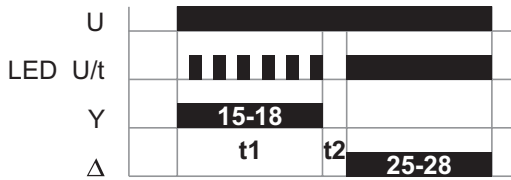

Connections

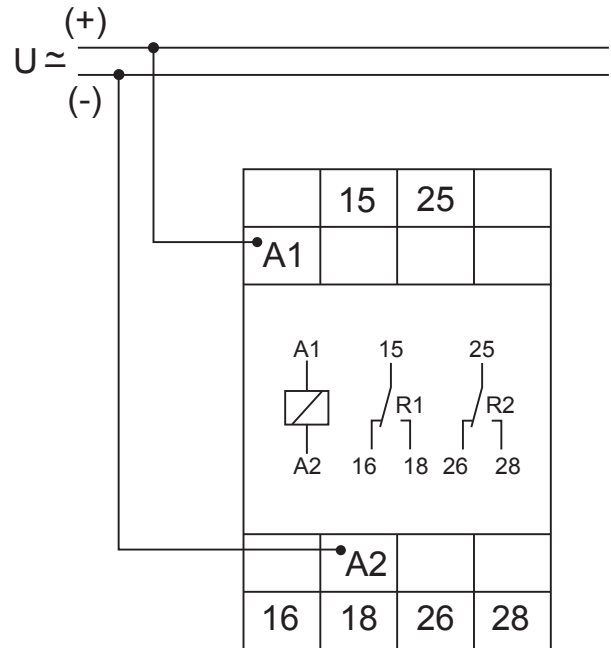

Dimensions

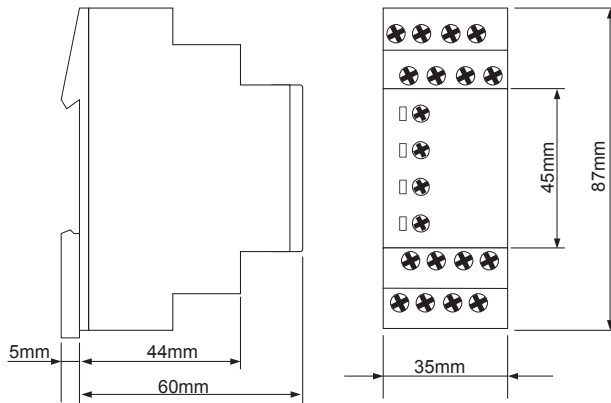

Ordering information

Type	Function	Supply Voltage	Part. No.
E3ZS20 12-240V AC/DC	S (Star-Delta) start up	12-240V AC/DC	111300



Series ENYA

Switch-off warning

Retrigger, time extension function programmable

Energy saving function

Impulse switch mode selectable

Low switching noise

High switching capacity, 80A peak inrush current

Automatic 3/4 - wire detection

Push-button glow lamp load up to 100mA

Width 17.5 mm

Installation design



Technical data

1. Functions

Electronic staircase lighting timer with switch-off warning. The control input allows the connection of pushbuttons with a total glow lamp load up to 100mA and enables the application in 3- or 4-wire circuits. The unit can be retrIGGERED via the connected pushbuttons. A long keypress will switch off the light (energy saving function). A fast sequence of pushes (pumping) will extend the period to a multiple of the selected value. Depending upon distinct type, the following operating methods can be selected by the controls on the unit:

- ☉ TW Automatic timer with switch-off warning
- ☉ T Automatic timer without switch-off warning
- ☉ 1 Steady light (ON)
- ☉ 0 Switch-off
- ⏏ P Impulse switch mode without time function (only types with option P)
- ⏏ PN Impulse switch mode power fail latch (only types with option PN)

Function sets on distinct types are according to table ordering information or printing on the unit.

2. Time range

Time	Adjustment range
	0,5 - 12min (in function T, TW)

3. Indicators

Green LED U ON:	indication of supply voltage
Yellow LED ON/OFF:	indication of relay output

4. Mechanical design

Self-extinguishing plastic housing, IP rating IP 40
 Mounted on DIN-rail TS 35 according to EN 60715
 Mounting position: any
 Shockproof terminal connection according to VBG 4 (PZ1 required), IP rating IP20
 Tightening torque: max. 1Nm
 Terminal capacity:
 1 x 0.5 to 2.5mm² with/without multicore cable end
 1 x 4mm² without multicore cable end
 2 x 0.5 to 1.5mm² with/without multicore cable end
 2 x 2.5mm² flexible without multicore cable end

5. Input circuit

Supply voltage:	239V a.c. terminals L - N
Tolerance:	-15% to +10%
Rated consumption:	2VA (1,0W)
Rated frequency:	a.c. 48 to 63Hz
Duty cycle:	100%
Reset time:	500ms
Hold-up time:	-
Residual ripple for d.c.:	-
Drop out voltage:	>30%
Overvoltage category:	III (in accordance with IEC 60664-1)
Rated surge voltage:	4kV

6. Output

1 normally open contact	terminals L - 18
Rated voltage:	250V a.c.
Switching capacity:	10A continuous current If the distance between the devices is less than 5mm.
Switching capacity:	16A continuous current If the distance between the devices is greater than 5mm.
Start-up peak (20ms):	80A
Mechanical life:	30 x 10 ⁶ operations
Electrical life	
Resistive load:	10 ⁵ operations at 16A 250V
Lamp load:	80.000 operations at 1000W 250V

7. Control input B1

Connection not potential free: pushbutton B1-N (3-conductor circuit)
 pushbutton B1-L (4-conductor circuit)
 Glow lamp load: max. 100mA parallel to the pushbuttons
 Overload protection: yes, electronic

8. Additional control input (only types with option C)

Connection:	control voltage on terminals C1(+)-C2
Voltage range:	8 ... 230V a.c./d.c.
Galvanic isolation:	yes, basic isolation
Overvoltage category:	III (in accordance with IEC 60664-1)
Rated surge voltage:	4kV

9. Accuracy

Base accuracy:	±5% of maximum scale value
Adjustment accuracy:	<15% of maximum scale value
Repetition accuracy:	<2%
Voltage influence:	-
Temperature influence:	≤1%

10. Ambient conditions

Ambient temperature:	-25 to +55°C
Storage temperature:	-25 to +70°C
Transport temperature:	-25 to +70°C
Relative humidity:	15% to 85% (in accordance with IEC 60721-3-3 class 3K3)
Pollution degree:	2 (in accordance with IEC 60664-1)

11. Weight

Single packing:	106g
-----------------	------

Functions

Function automatic timer (T, TW):

After the pushbutton at B1 has been pressed, the output relay R closes (terminals L-18) and the set interval t begins. If the pushbutton is pressed again before the interval t has expired, the interval begins again (restart function complies with EN 60669-2-3). Rapid, multiple pressing of the pushbutton (pumping) adds 2, 3 or more time intervals to extend the time up to 60min. Prolonged pressure on the button (>2s) aborts the interval running and switches the relay off (energy saving function). In the TW mode the device provides a switch-off warning (in accordance with DIN 180-158-2) by generating short pulses (flashing) at 30s, 15s and 5s prior to switch-off.

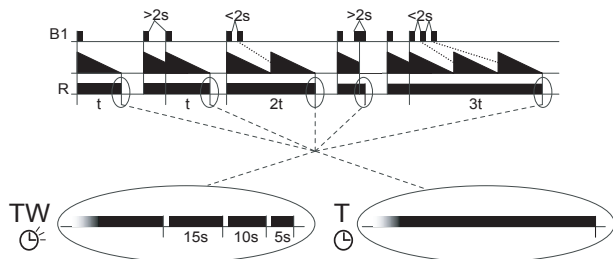

Operating possibilities at B1 in mode T and TW:

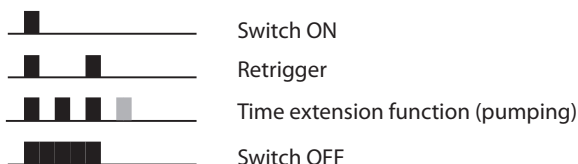

The additional control input C1-C2 can be used in the T and TW modes to control the staircase lighting timer with a voltage of 8 to 230V a.c. /d.c. . This input can be used to start and restart the cycle. It cannot be used for switch-off (energy saving function) or for programming long intervals (pumping).

Impulse switch mode (P), (PN):

In this mode, every keypress toggles the output relay R (flip-flop). In function P, the output relay R remains in off-position, whenever the supply voltage is applied.

In function PN, the output relay R switches into on-position after applying the supply voltage U, if the output relay R was in on-position last before power failure. The output relay R switches into on-position, if a short voltage impulse (<2s) is applied to the additional control input (C1-C2) (central ON). A longer voltage impulse (>2s) opens the output relay R (central OFF).

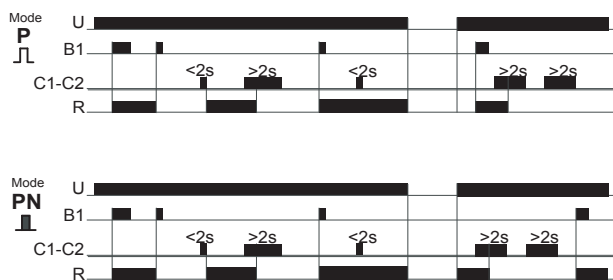

Connections

3-wire-circuit

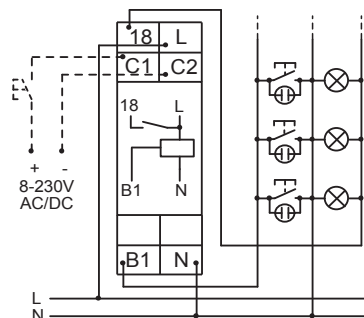

4-wire-circuit with attic illumination

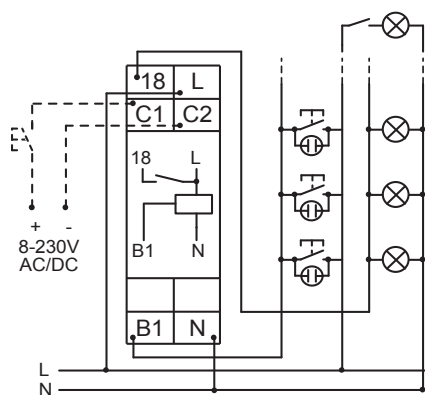

Dimensions

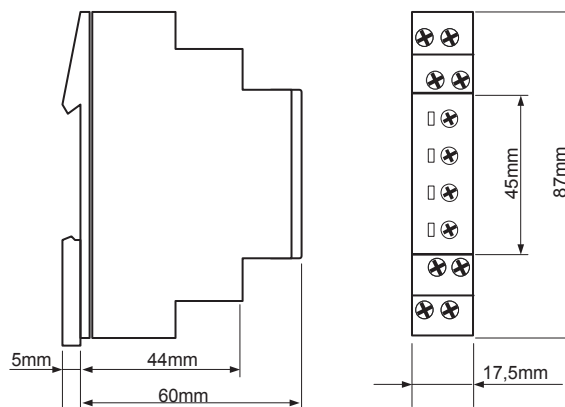

Ordering information

Types	Functions	Additional control input	Supply voltage	Part. No.
E1ZTP 230V AC	TW, 1, 0, P	no	230V a.c.	110301
E1ZTPNC 230V AC	T, TW, 1, 0, P, PN	C1-C2	230V a.c.	110300



ENYA series

Energy saving function

Low switching noise

High switching capacity, 80A peak inrush current

Automatic 3/4 - wire detection

Push-button glow lamp load up to 100mA

Width 17.5mm

Installation design



Technical data

1. Functions

Impulse switch mode with off delay.

The control input allows the connection of pushbuttons with a glow lamp load up to 100mA and enables the application in 3- or 4-wire circuits. The unit can be switch-on and off via the connected pushbuttons.

2. Time ranges

Adjustment range
Time 6 to 60min

3. Indicators

Green LED U ON: indication of supply voltage
Yellow LED ON/OFF: indication of relay output

4. Mechanical design

Self extinguishing plastic housing, IP rating IP 40
Mounted on Din-rail TS 35 according to EN 60715
Mounting position: any
Shockproof terminal connection according to VBG 4 (PZ1 required), IP rating IP20
Tightening torque: max. 1Nm
Terminals capacity:
1 x 0.5 to 2.5mm² with/without multicore cable end
1 x 4mm² without multicore cable end
2 x 0.5 to 1.5mm² with/without multicore cable end
2 x 2.5mm² flexible without multicore cable end

5. Input circuit

Supply voltage: Terminals L - N
Rated voltage: see table ordering information or printing on the unit
Tolerance: -15% to +10%
Rated consumption: 2VA (1,0W)
Rated frequency: AC 48 to 63Hz
Duty cycle: 100%
Reset time: 500ms
Hold-up time: -
Residual ripple for DC: -
Drop-out voltage: >30%
Overvoltage category: III (in accordance with IEC 60664-1)
Rated surge voltage: 4kV

6. Output

1 normally open contact terminals L - 18
Rated voltage: 250V AC
Switching capacity: 10A continuous current
If the distance between the devices is less than 5mm!

Switching capacity: 16A continuous current
If the distance between the devices is greater than 5mm!

Start-up peak (20ms): 80A
Mechanical life: 30 x 10⁶ operations
Electrical life:
Resistive load: 10⁵ operations at 16A 250V
Lamp load: 80.000 operations at 1000W 250V

7. Control input B1

Connection not potential free: pushbuttons B1-N (3-conductor circuit)
pushbuttons B1-L (4-conductor circuit)
Glow lamp load: max. 100mA parallel to the pushbuttons
Overload protection: yes, electronic

8. Accuracy

Base accuracy: ±5% of maximum scale value
Adjustment accuracy: <15% of maximum scale value
Repetition accuracy: <2%
Voltage influence: -
Temperature influence: ≤1%

9. Ambient conditions

Ambient temperature: -25 to +55°C
Storage temperature: -25 to +70°C
Transport temperature: -25 to +70°C
Relative humidity: 15% to 85%
(in accordance with IEC 60721-3-3 class 3K3)
2, if built in 3
(in accordance with IEC 60664-1)

Pollution degree:

11. Weight

Single packing: 57g

Functions

Impulse switch mode with off delay:

In this mode, every keypress toggles the output relay R (flip-flop). After the pushbutton at B1 has been pressed, the output relay R closes (terminals L-18 / yellow LED illuminated) and the set interval t begins. After the interval t has expired the output relay R switches into off-position (yellow LED not illuminated). If the pushbutton is pressed again before the interval t has expired, the interval t will be canceled and the output relay R switches into off-position (yellow LED not illuminated).



Dimensions

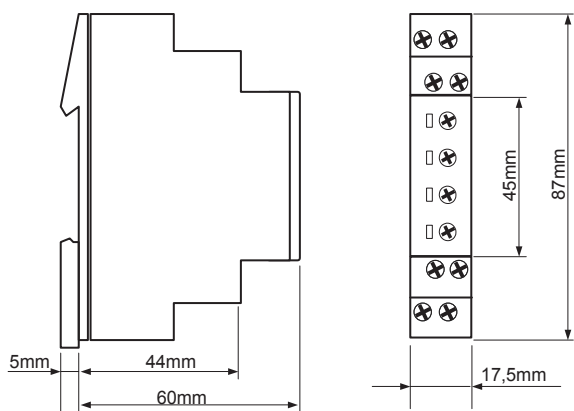

Connections

3-wire-circuit

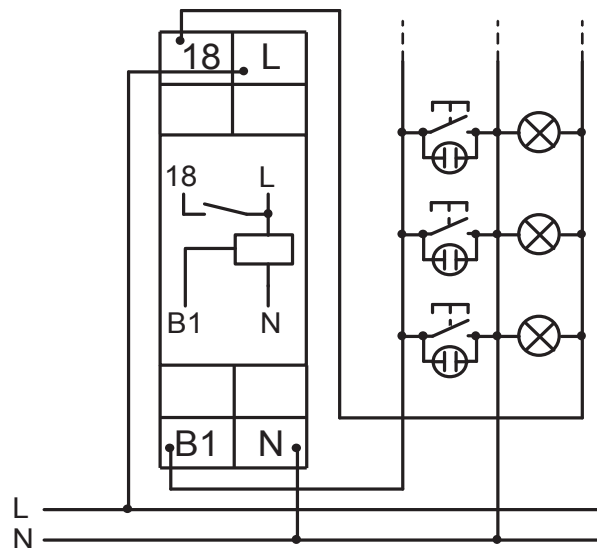

4-wire-circuit with attic illumination

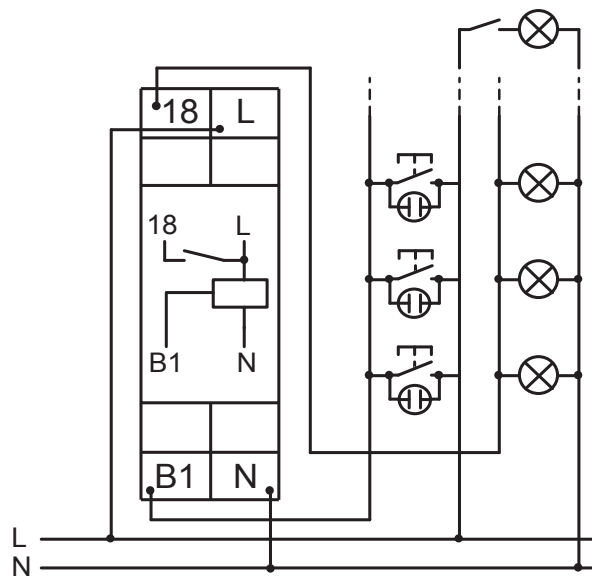

Ordering Informations

Types	Time ranges	Supply Voltage	Part. No.
E1ZWI 60min 230V AC	6 to 60min	230V AC	110310



ENYA series

Timer for automatic test of emergency lights

Integrated test key

1 change over contact

Width 17.5mm

Installation design



Technical data

1. Functions

Ws Single shot leading edge with control contact

2. Time ranges

Time range reversible between
10min, 30min, 60min, 90min, 2h and 3h

3. Indicators

Green LED U/t ON: indication of supply voltage
Green LED U/t flashes: indication of time period t
Green LED U/t flashes fast: abort of time period t
Yellow LED ON/OFF: indication of relay output

4. Mechanical design

Self-extinguishing plastic housing, IP rating IP 40
Mounted on DIN-rail TS 35 according to EN 60715
Mounting position: any
Shockproof terminal connection according to VBG 4 (PZ1 required),
IP rating IP20
Tightening torque: max. 1Nm
Terminal capacity:
1 x 0.5 to 2.5mm² with/without multicore cable end
1 x 4mm² without multicore cable end
2 x 0.5 to 1.5mm² with/without multicore cable end
2 x 2.5mm² flexible without multicore cable end

5. Input circuit

Supply voltage: 230V AC
Terminals: L-N
Tolerance: -15% to +10%
Rated frequency: 48 to 63Hz
Rated consumption: 2VA (1.0W)
Duty cycle: 100%
Reset time: 500ms
Ripple and noise at DC: -
Drop out voltage: >30% of supply voltage
Overvoltage category: III (in accordance with IEC 60664-1)
Rated surge voltage: 4kV

6. Output circuit

1 change over contact
Normally open contact
Terminals: L-18
Rated voltage: 250V AC
Switching capacity: 1250VA (5A / 250V AC)

Normally closed contact

Terminals: L-16
Rated voltage: 250V AC
Switching capacity: 2500VA (10A / 250V AC)
If the distance between the devices is less than 5mm!

Switching capacity: 4000VA (16A / 250V AC)
If the distance between the devices is greater than 5mm!
Start-up peak (20ms): 80A

Mechanical life: 30 x 10⁶ operations
Electrical life:
Resistive load: 10⁵ operations at 16A 250V
Lamp load: 80.000 operations at 1000W 250V

7. Accuracy

Base accuracy: ±5%
Adjustment accuracy: -
Repetition accuracy: <2%
Voltage influence: -
Temperature influence: ≤1%

8. Ambient conditions

Ambient temperature: -25 to +55°C
Storage temperature: -25 to +70°C
Transport temperature: -25 to +70°C
Relative humidity: 15% to 85%
(in accordance with IEC 60721-3-3 class 3K3)
Pollution degree: 2, if built in 3
(in accordance with IEC 60664-1)

Functions

Single shot leading edge with testkey (Ws)

The supply voltage U must be constantly to the device (green LED U/t illuminated). Pressing the integrated test key forces the output relay R to switch into on-position (yellow LED illuminated), so the emergency lights are disconnected from the mains and the set interval t begins (green LED U/t flashes). After the interval t has expired (green LED U/t illuminated), the output relay R switches into off-position (yellow LED not illuminated) and the emergency lights are reconnected to the mains. During the interval, the test key can be operated any number of times. Prolonged pressure on the test key (>2s) aborts the running test interval (green LED U/t flashes fast) and a further cycle can be started.

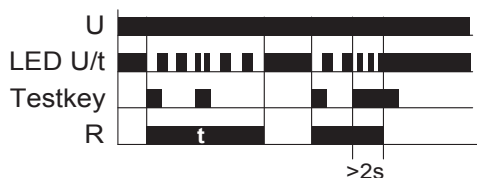

Dimensions

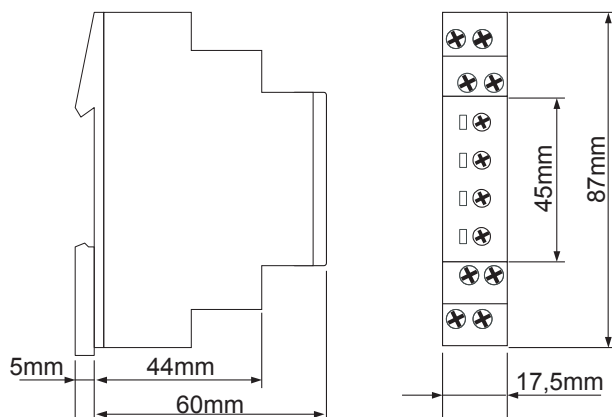

Connections

Direct connection of emergency lights ($I < 16A$)

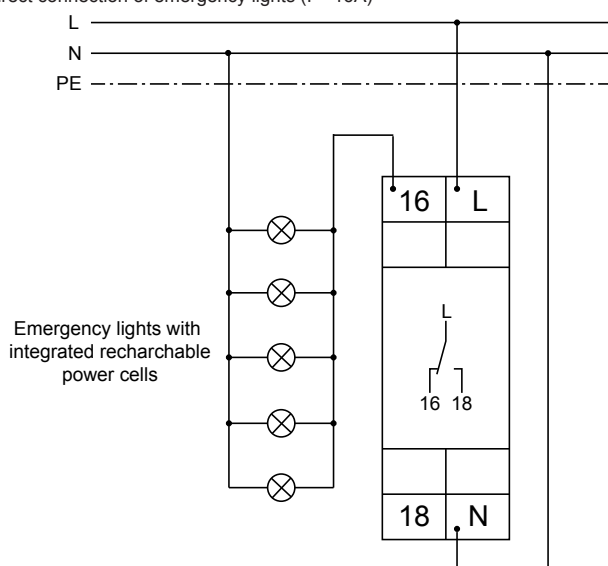

Switching emergency lights with contactor ($I > 16A$)

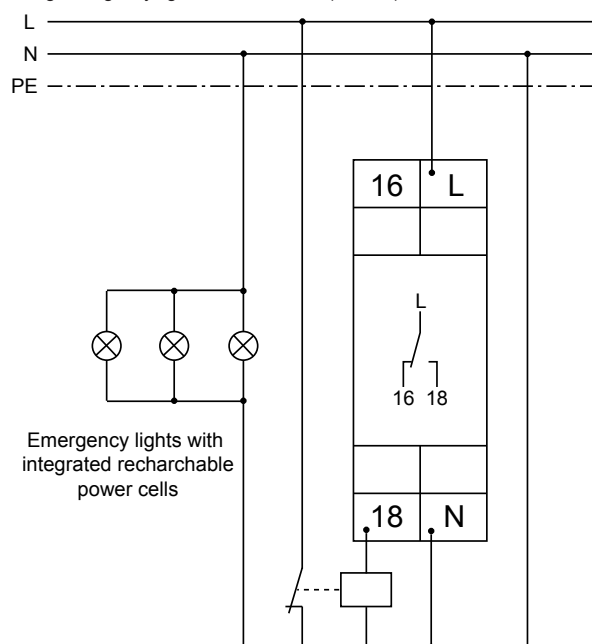

Ordering information

Types	Functions	Control contact	Supply voltage	Part. No.
E1ZNT 230V	Ws	Integrated test key	230V AC	110500



VEO

TIME RELAY / SINGLE-FUNCTION TIME RELAY

V2ZE10 24-240V AC/DC

Art.Nr.: 125110

V2ZE10P 24-240V AC/DC

Art.Nr.: 125610



- ✓ On-Delay
- ✓ 10 time ranges
- ✓ Supply voltage 24-240V AC/DC
- ✓ 1 change-over contact
- ✓ Width 22,5mm

Control elements

- ✓ Fine adjustment
- ✓ Setting of time range

Status indication

- ✓ LED U/t: Supply voltage
- ✓ LED R: Relay status



TECHNICAL DATA

SUPPLY CIRCUIT

Terminals	A1-A2	
Supply voltage	24 ... 240 V AC/DC	
Supply voltage tolerance	-15 / +10 %	
Rated frequency	50/60 Hz or DC	
Rated frequency tolerance	48 ... 63 Hz	
Rated consumption	230 V AC	typ. 0,35 W / 0,7 VA
	24 V DC	typ. 0,25 W / 0,25 VA
Standby consumption	230 V AC	typ. 0,16 W / 0,3 VA
	24 V DC	typ. 0,03 W / 0,09 VA
Duty-cycle	100%	
Backup power time	< 30 ms	
Recovery time	> 100 ms	
Drop-out voltage	≥ 15,5 V	

TIMING CIRCUIT

Time ranges	10	0,05 ... 1 s
		0,15 ... 3 s
		0,5 ... 10 s
		1,5 ... 30 s
		3 ... 60 s
		9 ... 180 s
		0,5 ... 10 min
		3 ... 60 min
		0,5 ... 10 h
		5 ... 100 h



VEO

TIME RELAY / SINGLE-FUNCTION TIME RELAY

V2ZE10 24-240V AC/DC

Art.Nr.: 125110

V2ZE10P 24-240V AC/DC

Art.Nr.: 125610



RANGE OF FUNCTIONS

Functions	1	E
-----------	---	---

STATUS INDICATION

Supply voltage / time lapse	LED U/t (green) on	supply voltage applied
	LED U/t (green) flashes	indication of lapse of time
Relay status	LED R (yellow) on	output relay energized

OUTPUT CIRCUIT

Terminals		15-16-18
Kind of output		Relay
Number of contacts	change-over contact	1
Contact material		AgNi
Rated voltage (IEC 60947-5-1)		250 V
Maximum switching voltage		400 V AC
Minimum switching voltage / switching current		12 V / 10 mA
Rated current (IEC 60947-5-1)	AC-1	8 A / 250 V
	AC-15	1,5 A / 240 V (B300)
	DC-12	8 A / 24 V
	DC-13	0,1 A / 250 V
Endurance	mechanical	20 x 10 ⁶ switching cycles
	electrical (AC-1)	100 x 10 ³ switching cycles
Rated frequency of operation	with load	6/min
	without load	1200/min

ACCURACY

Base accuracy	< 1 % (of full scale)
Setting accuracy	< 5 % (of full scale)
Repeat accuracy	< 0,5 % or ±5 ms
Temperature influence	< 0,01 % / °C
Voltage influence	-
Frequency influence	-



VEO

TIME RELAY / SINGLE-FUNCTION TIME RELAY

V2ZE10 24-240V AC/DC

Art.Nr.: 125110

V2ZE10P 24-240V AC/DC

Art.Nr.: 125610



ENVIRONMENTAL CONDITIONS

Ambient temperature	operation	-25 ... +60 °C
	storage	-40 ... +70 °C
Relative humidity		5 ... 95 %
Vibration	EN 61812-1	10 ... 60 Hz: 0,15 mm; 60 ... 150 Hz: 20 m/s ²
	EN 60947-1	2 ... 13,2 Hz: 1 mm; 13,2 ... 100 Hz: 7 m/s ²
Shock	EN 60947-1	±150 m/s ² 11 ms

GENERAL DATA

Dimensions	W × H × D	22,5 x 67 x 76 mm
Mounting		DIN rail (EN60715)
Mounting position		any
Housing material		PA 66, self-extinguishing plastic, class V-0
Degree of protection	housing	IP40
	terminals	IP20
Electrical connection	V2ZE10	Screw terminal
Wire size	flexible with wire end ferrule	0,5 ... 2,5 mm ² (20 AWG ... 13 AWG)
	flexible without wire end ferrule	0,5 ... 4 mm ² (20 AWG ... 12 AWG)
	rigid	0,5 ... 4 mm ² (20 AWG ... 12 AWG)
Stripping length		8 mm
Tightening torque		max. 1Nm
Electrical connection	V2ZE10P	Push-in terminal
Wire size	flexible with wire end ferrule	0,25 ... 1,5 mm ² (24 AWG ... 16 AWG)
	flexible with plastic ferrule	0,25 ... 0,75 mm ² (24 AWG ... 19 AWG)
	flexible without wire end ferrule	0,2 ... 1,5 mm ² (24 AWG ... 16 AWG)
	rigid	0,2 ... 1,5 mm ² (24 AWG ... 16 AWG)
Stripping length		8 mm
Prospective current value		1000 A _{Eff}
Fuse rating		8A fast acting
MTTF		-
Weight		84 g

ISOLATION DATA

Pollution degree (IEC 61812-1)		2
Overvoltage category (IEC 61812-1)		III



VEO

TIME RELAY / SINGLE-FUNCTION TIME RELAY

V2ZE10 24-240V AC/DC

Art.Nr.: 125110

V2ZE10P 24-240V AC/DC

Art.Nr.: 125610



ISOLATION DATA

Rated Insulation voltage (IEC 61812-1)	supply circuit / output circuit	300 V
Rated impulse withstanding voltage (IEC 61812-1)	supply circuit / output circuit	6 kV
Insulation test voltage (IEC 61812-1)	supply circuit / output circuit	3200 V
Insulation	supply circuit / output circuit	protective seperation

STANDARDS

Product standard	IEC 61812-1	
Interference immunity	IEC 61812-1	class A
Interference emission	IEC 61812-1	class A
Approvals		

FUNCTIONS

ON delay (E)

When the supply voltage U is applied, the set interval t begins (green LED U/t flashes). After the interval t has expired (green LED U/t illuminated) the output relay R switches into on-position (yellow LED illuminated). This status remains until the supply voltage is interrupted. If the supply voltage is interrupted before the expiry of the interval t, the interval already expired is erased and is restarted when the supply voltage is next applied.

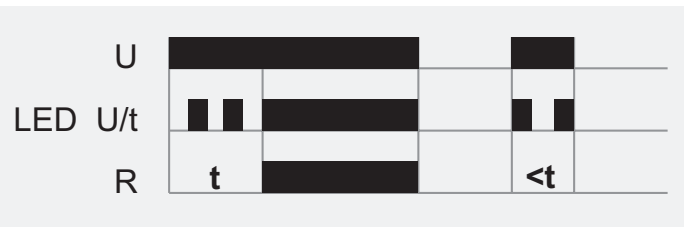



VEO

TIME RELAY / SINGLE-FUNCTION TIME RELAY

V2ZE10 24-240V AC/DC

Art.Nr.: 125110

V2ZE10P 24-240V AC/DC

Art.Nr.: 125610



CONNECTIONS

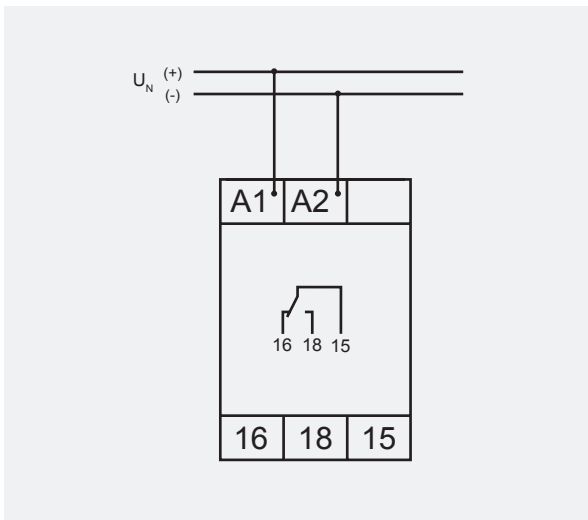

DIMENSIONS

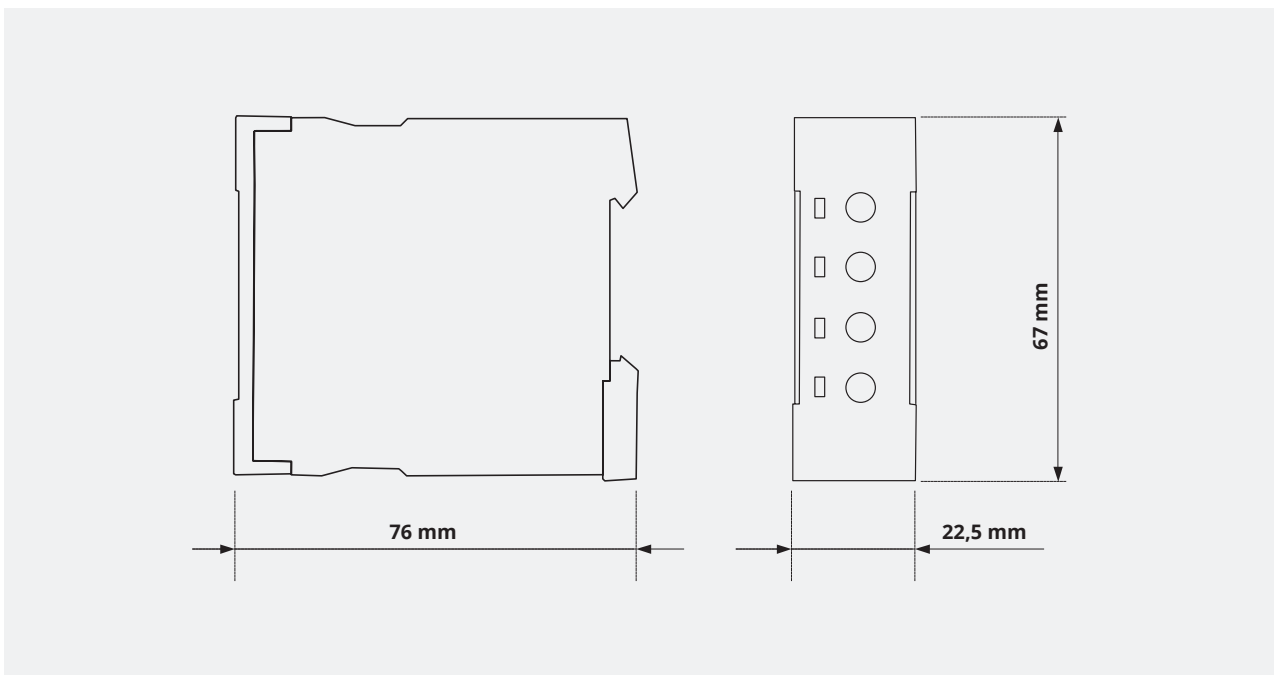



VEO

TIME RELAY / SINGLE-FUNCTION TIME RELAY

V2ZR10 24-240V AC/DC

Art.Nr.: 125120

V2ZR10P 24-240V AC/DC

Art.Nr.: 125620



- ✓ Off-Delay
- ✓ 10 time ranges
- ✓ Supply voltage 24-240V AC/DC
- ✓ 1 change-over contact
- ✓ Width 22,5 mm

Control elements

- ✓ Fine adjustment
- ✓ Setting of time range

Status indication

- ✓ LED U/t: Supply voltage
- ✓ LED R: Relay status



TECHNICAL DATA

SUPPLY CIRCUIT

Terminals	A1-A2	
Supply voltage	24 ... 240 V AC/DC	
Supply voltage tolerance	-15 / +10 %	
Rated frequency	50 / 60 Hz or DC	
Rated frequency tolerance	48 ... 63 Hz	
Rated consumption	230 V AC	typ. 0,4 W / 0,75 VA
	24 V DC	typ. 0,25 W / 0,25 VA
Standby consumption	230 V AC	typ. 0,16 W / 0,3 VA
	24 V DC	typ. 0,03 W / 0,09 VA
Duty-cycle	100%	
Backup power time	< 30 ms	
Recovery time	> 100 ms	
Drop-out voltage	≥ 15,5 V	

CONTROL INPUT

Terminals	A1-B1	
Function	start of function	
Type	voltage controlled	
Control voltage	see supply voltage	
Minimum control pulse length	AC	min. 50 ms
	DC	min. 25 ms
Loadable	yes	



VEO

TIME RELAY / SINGLE-FUNCTION TIME RELAY

V2ZR10 24-240V AC/DC

Art.Nr.: 125120

V2ZR10P 24-240V AC/DC

Art.Nr.: 125620



TIMING CIRCUIT

Time ranges	10	0,05 ... 1 s
		0,15 ... 3 s
		0,5 ... 10 s
		1,5 ... 30 s
		3 ... 60 s
		9 ... 180 s
		0,5 ... 10 min
		3 ... 60 min
		0,5 ... 10 h
		5 ... 100 h

RANGE OF FUNCTIONS

Functions	1	R
-----------	---	---

STATUS INDICATION

Supply voltage / time lapse	LED U/t (green) on	supply voltage applied
	LED U/t (green) flashes	indication of lapse of time
Relay status	LED R (yellow) on	output relay energized

OUTPUT CIRCUIT

Terminals		15-16-18
Kind of output		Relay
Number of contacts	change-over contact	1
Contact material		AgNi
Rated voltage (IEC 60947-5-1)		250 V
Maximum switching voltage		400 V AC
Minimum switching voltage / switching current		12 V / 10 mA
Rated current (IEC 60947-5-1)	AC-1	8 A / 250 V
	AC-15	1,5 A / 240 V (B300)
	DC-12	8 A / 24 V
	DC-13	0,1 A / 250 V
Endurance	mechanical	30 x 10 ⁶ switching cycles
	electrical (AC-1)	100 x 10 ³ switching cycles
Rated frequency of operation	with load	6/min
	without load	1200/min



VEO

TIME RELAY / SINGLE-FUNCTION TIME RELAY

V2ZR10 24-240V AC/DC

Art.Nr.: 125120

V2ZR10P 24-240V AC/DC

Art.Nr.: 125620



ACCURACY

Base accuracy	< 1 % (of full scale)
Setting accuracy	< 5 % (of full scale)
Repeat accuracy	< 0,5 % or ± 5 ms
Temperature influence	< 0,01 % / °C
Voltage influence	-
Frequency influence	-

ENVIRONMENTAL CONDITIONS

Ambient temperature	operation	-25 ... +60 °C
	storage	-40 ... +70 °C
Relative humidity		5 ... 95 %
Vibration	EN 61812-1	10 ... 60 Hz: 0,15 mm; 60 ... 150 Hz: 20 m/s ²
	EN 60947-1	2 ... 13,2 Hz: 1 mm; 13,2 ... 100 Hz: 7 m/s ²
Shock	EN 60947-1	± 150 m/s ² 11 ms

GENERAL DATA

Dimensions	W × H × D	22,5 × 67 × 76 mm
Mounting		DIN rail (EN60715)
Mounting position		any
Housing material		PA 66, self-extinguishing plastic, class V-0
Degree of protection	housing	IP40
	terminals	IP20
Electrical connection	V2ZR10	Screw terminal
Wire size	flexible with wire end ferrule	0,5 ... 2,5 mm ² (20 AWG ... 13 AWG)
	flexible without wire end ferrule	0,5 ... 4 mm ² (20 AWG ... 12 AWG)
	rigid	0,5 ... 4 mm ² (20 AWG ... 12 AWG)
Stripping length		8 mm
Tightening torque		max. 1Nm
Electrical connection	V2ZR10P	Push-in terminal
Wire size	flexible with wire end ferrule	0,25 ... 1,5 mm ² (24 AWG ... 16 AWG)
	flexible with plastic ferrule	0,25 ... 0,75 mm ² (24 AWG ... 19 AWG)
	flexible without wire end ferrule	0,2 ... 1,5 mm ² (24 AWG ... 16 AWG)
	rigid	0,2 ... 1,5 mm ² (24 AWG ... 16 AWG)
Stripping length		8 mm



VEO

TIME RELAY / SINGLE-FUNCTION TIME RELAY

V2ZR10 24-240V AC/DC

Art.Nr.: 125120

V2ZR10P 24-240V AC/DC

Art.Nr.: 125620



GENERAL DATA

Prospective current value	1000 A _{eff}
Fuse rating	8A fast acting
MTTF	-
Weight	84 g

ISOLATION DATA

Pollution degree (IEC 61812-1)	2
Overvoltage category (IEC 61812-1)	III
Rated insulation voltage (IEC 61812-1)	supply circuit / output circuit 300 V
Rated impulse withstanding voltage (IEC 61812-1)	supply circuit / output circuit 6 kV
Insulation test voltage (IEC 61812-1)	supply circuit / output circuit 3200 V
Degree of protection	supply circuit / output circuit protective separation

STANDARDS

Product standard	IEC 61812-1
Interference immunity	IEC 61812-1 class A
Interference emission	IEC 61812-1 class A
Approvals	



VEO

TIME RELAY / SINGLE-FUNCTION TIME RELAY

V2ZR10 24-240V AC/DC

Art.Nr.: 125120

V2ZR10P 24-240V AC/DC

Art.Nr.: 125620



FUNCTIONS

OFF delay with control input (R)

The supply voltage U must be constantly applied to the device (green LED U/t illuminated). When the control contact S is closed, the output relay R switches into on-position (yellow LED illuminated). If the control contact is opened, the set interval t begins (green LED U/t flashes). After the interval t has expired (green LED U/t illuminated) the output relay switches into off-position (yellow LED not illuminated). If the control contact is closed again before the interval t has expired, the interval already expired is erased and is restarted.

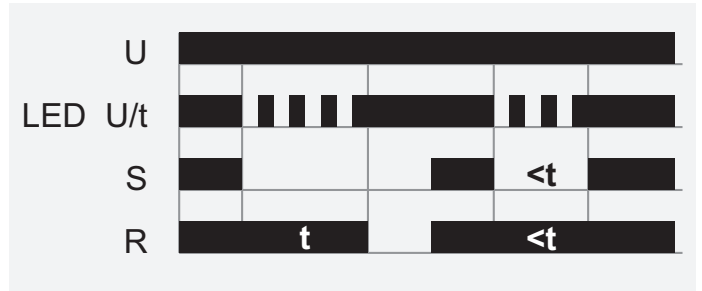

CONNECTIONS

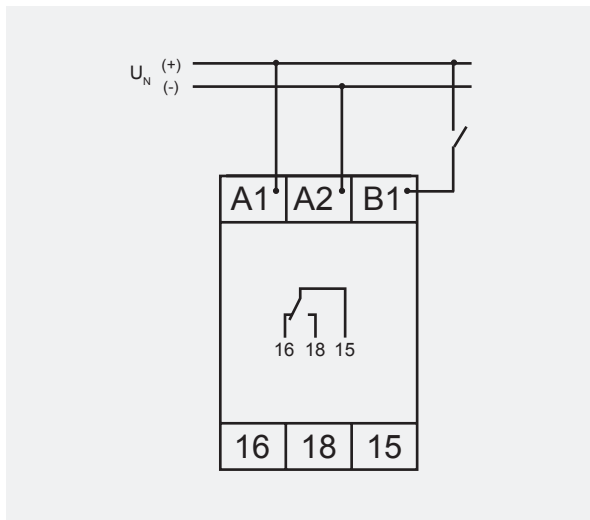



VEO

TIME RELAY / SINGLE-FUNCTION TIME RELAY

V2ZR10 24-240V AC/DC

Art.Nr.: 125120

V2ZR10P 24-240V AC/DC

Art.Nr.: 125620



DIMENSIONS

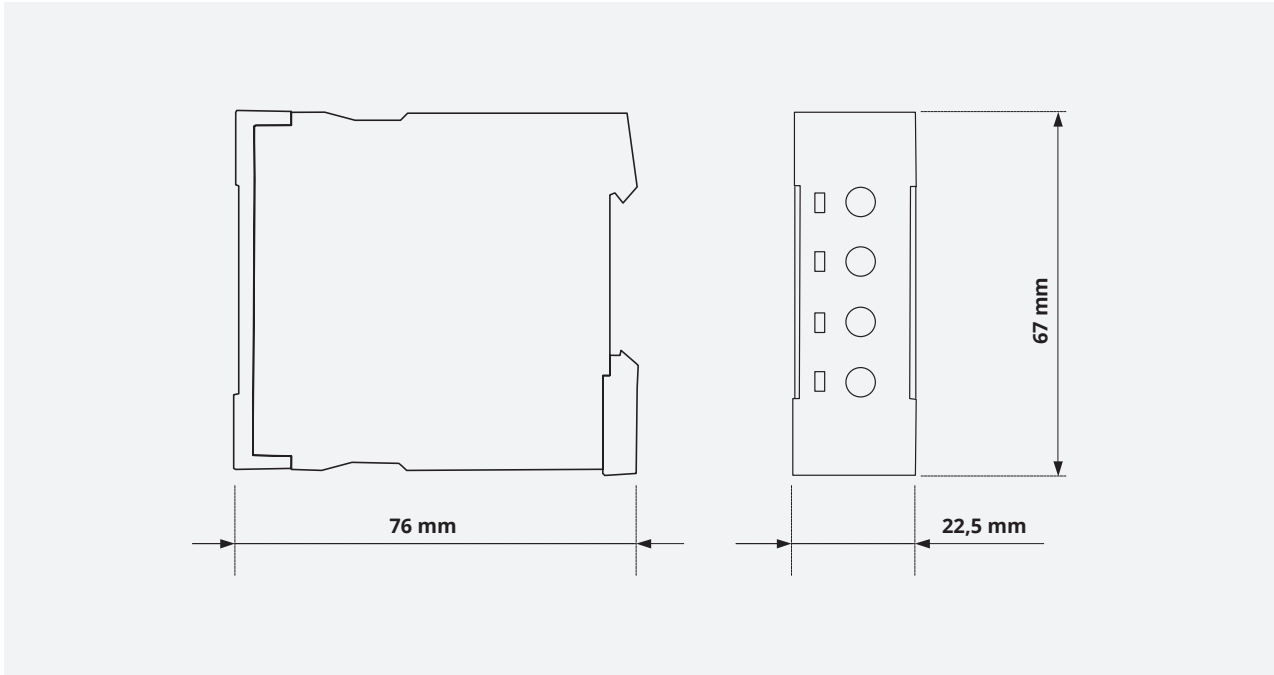



VEO

TIME RELAY / ASYMMETRIC FLASHER

V2ZI10 12-240V AC/DC

Art.Nr.: 125200

V2ZI10P 12-240V AC/DC

Art.Nr.: 125210



- ✓ 2 functions
- ✓ 10 time ranges
- ✓ Supply voltage 12-240V AC/DC
- ✓ 1 change-over contact
- ✓ Width 22,5mm

Control elements

- ✓ Fine adjustment t1
- ✓ Setting of time range t1
- ✓ Fine adjustment t2
- ✓ Setting of time range t2

Status indication

- ✓ LED U/t: Supply voltage
- ✓ LED R: Relay status



TECHNICAL DATA

SUPPLY CIRCUIT

Terminals	A1-A2	
Supply voltage	12 ... 240 V AC/DC	
Supply voltage tolerance	-10 / +10 %	
Rated frequency	50 / 60 Hz or DC	
Rated frequency tolerance	48 ... 63 Hz	
Rated consumption	230 V AC	typ. 0,4 W / 0,75 VA
	24 V DC	typ. 0,25 W / 0,25 VA
Standby consumption	230 V AC	typ. 0,16 W / 0,3 VA
	24 V DC	typ. 0,03 W / 0,09 VA
Duty-cycle	100%	
Backup power time	< 30 ms	
Recovery time	> 100 ms	
Drop-out voltage	≥ 7 V	

CONTROL INPUT

Terminals	A1-B1
Function	switch of functions
Type	voltage controlled
Control voltage	see supply voltage
Loadable	yes
Minimum control pulse length	> 60 ms



VEO

TIME RELAY / ASYMMETRIC FLASHER

V2ZI10 12-240V AC/DC

Art.Nr.: 125200

V2ZI10P 12-240V AC/DC

Art.Nr.: 125210



TIMING CIRCUIT

Time ranges	10	0,05 ... 1 s
		0,15 ... 3 s
		0,5 ... 10 s
		1,5 ... 30 s
		3 ... 60 s
		9 ... 180 s
		0,5 ... 10 min
		3 ... 60 min
		0,5 ... 10 h
		5 ... 100 h

RANGE OF FUNCTIONS

Functions	2	lp, li
-----------	---	--------

STATUS INDICATION

Supply voltage / time lapse	LED U/t (green) on	supply voltage applied
	LED U/t (green) flashes slowly	indication of lapse of time t1
	LED U/t (green) flashes rapidly	indication of lapse of time t2
Relay status	LED R (yellow) on	output relay energized

OUTPUT CIRCUIT

Terminals		15-16-18
Kind of output		Relay
Number of contacts	change-over contact	1
Contact material		AgNi
Rated voltage (IEC 60947-5-1)		250 V
Maximum switching voltage		400 V AC
Minimum switching voltage / switching current		12 V / 10 mA
Rated current (IEC 60947-5-1)	AC-1	8 A / 250 V
	AC-15	1,5 A / 240 V (B300)
	DC-12	8 A / 24 V
	DC-13	0,1 A / 250 V
Endurance	mechanical	20 x 10 ⁶ switching cycles
	electrical (AC-1)	100 x 10 ³ switching cycles
Rated frequency of operation	with load	6/min
	without load	1200/min



VEO

TIME RELAY / ASYMMETRIC FLASHER

V2ZI10 12-240V AC/DC

Art.Nr.: 125200

V2ZI10P 12-240V AC/DC

Art.Nr.: 125210



ACCURACY

Base accuracy	< 1 % (of full scale)
Setting accuracy	< 5 % (of full scale)
Repeat accuracy	< 0,5 % or ±5 ms
Temperature influence	< 0,01 % / °C
Voltage influence	-
Frequency influence	-

ENVIRONMENTAL CONDITIONS

Ambient temperature	operation	-25 ... +60 °C
	storage	-40 ... +70 °C
Relative humidity		5 ... 95 %
Vibration	EN 61812-1	10 ... 60 Hz: 0,15 mm; 60 ... 150 Hz: 20 m/s ²
	EN 60947-1	2 ... 13,2 Hz: 1 mm; 13,2 ... 100 Hz: 7 m/s ²
Shock	EN 60947-1	±150 m/s ² 11 ms

GENERAL DATA

Dimensions	W × H × D	22,5 x 67 x 76 mm
Mounting		DIN rail (EN60715)
Mounting position		any
Housing material		PA 66, self-extinguishing plastic, class V-0
Degree of protection	housing	IP40
	terminals	IP20
Electrical connection	V2ZI10	Screw terminal
Wire size	flexible with wire end ferrule	0,5 ... 2,5 mm ² (20 AWG ... 13 AWG)
	flexible without wire end ferrule	0,5 ... 4 mm ² (20 AWG ... 12 AWG)
	rigid	0,5 ... 4 mm ² (20 AWG ... 12 AWG)
Stripping length		8 mm
Tightening torque		max. 1Nm
Electrical connection	V2ZI10P	Push-in terminal
Wire size	flexible with wire end ferrule	0,25 ... 1,5 mm ² (24 AWG ... 16 AWG)
	flexible with plastic ferrule	0,25 ... 0,75 mm ² (24 AWG ... 19 AWG)
	flexible without wire end ferrule	0,2 ... 1,5 mm ² (24 AWG ... 16 AWG)
	rigid	0,2 ... 1,5 mm ² (24 AWG ... 16 AWG)
Stripping length		8 mm



VEO

TIME RELAY / ASYMMETRIC FLASHER

V2ZI10 12-240V AC/DC

Art.Nr.: 125200

V2ZI10P 12-240V AC/DC

Art.Nr.: 125210



GENERAL DATA

Prospective current value	1000 A _{Eff}
Fuse rating	8A fast acting
MTTF	-
Weight	85 g

ISOLATION DATA

Pollution degree (IEC 61812-1)	2
Overvoltage category (IEC 61812-1)	III
Rated insulation voltage (IEC 61812-1)	supply circuit / output circuit 300 V
Rated impulse withstanding voltage (IEC 61812-1)	supply circuit / output circuit 6 kV
Insulation test voltage (IEC 61812-1)	supply circuit / output circuit 3200 V
Insulation	supply circuit / output circuit protective separation

STANDARDS

Product standard	IEC 61812-1
Interference immunity	IEC 61812-1 class A
Interference emission	IEC 61812-1 class A
Approvals	



VEO

TIME RELAY / ASYMMETRIC FLASHER

V2ZI10 12-240V AC/DC

Art.Nr.: 125200

V2ZI10P 12-240V AC/DC

Art.Nr.: 125210



FUNCTIONS

Asymmetric flasher pulse first (li)

When the supply voltage U is applied, the output relay R switches into on-position (yellow LED illuminated) and the set interval t1 begins (green LED U/t flashes slowly). After the interval t1 has expired, the output relay switches into off-position (yellow LED not illuminated) and the set interval t2 begins (green LED U/t flashes fast). After the interval t2 has expired, the output relay switches into on-position (yellow LED illuminated). The output relay is triggered at the ratio of t1:t2 until the supply voltage is interrupted.

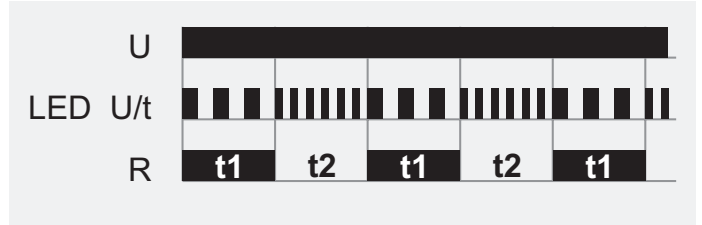

Asymmetric flasher pause first (lp)

When the supply voltage U is applied, the set interval t1 begins (green LED U/t flashes slowly). After the interval t1 has expired, the output relay R switches into on-position (yellow LED illuminated) and the set interval t2 begins (green LED U/t flashes fast). After the interval t2 has expired, the output relay switches into off-position (yellow LED not illuminated). The output relay is triggered at the ratio of t1:t2 until the supply voltage is interrupted.

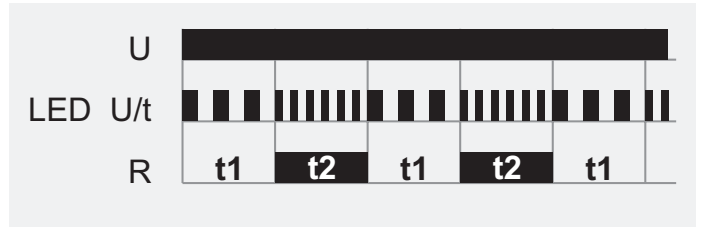

CONNECTIONS

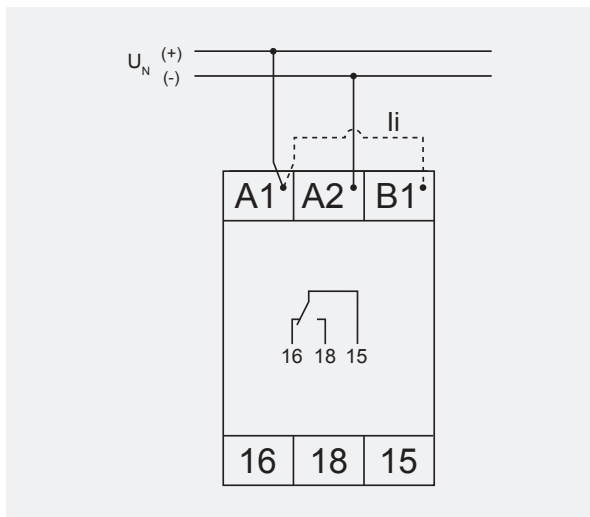



VEO

TIME RELAY / ASYMMETRIC FLASHER

V2ZI10 12-240V AC/DC

Art.Nr.: 125200

V2ZI10P 12-240V AC/DC

Art.Nr.: 125210



DIMENSIONS

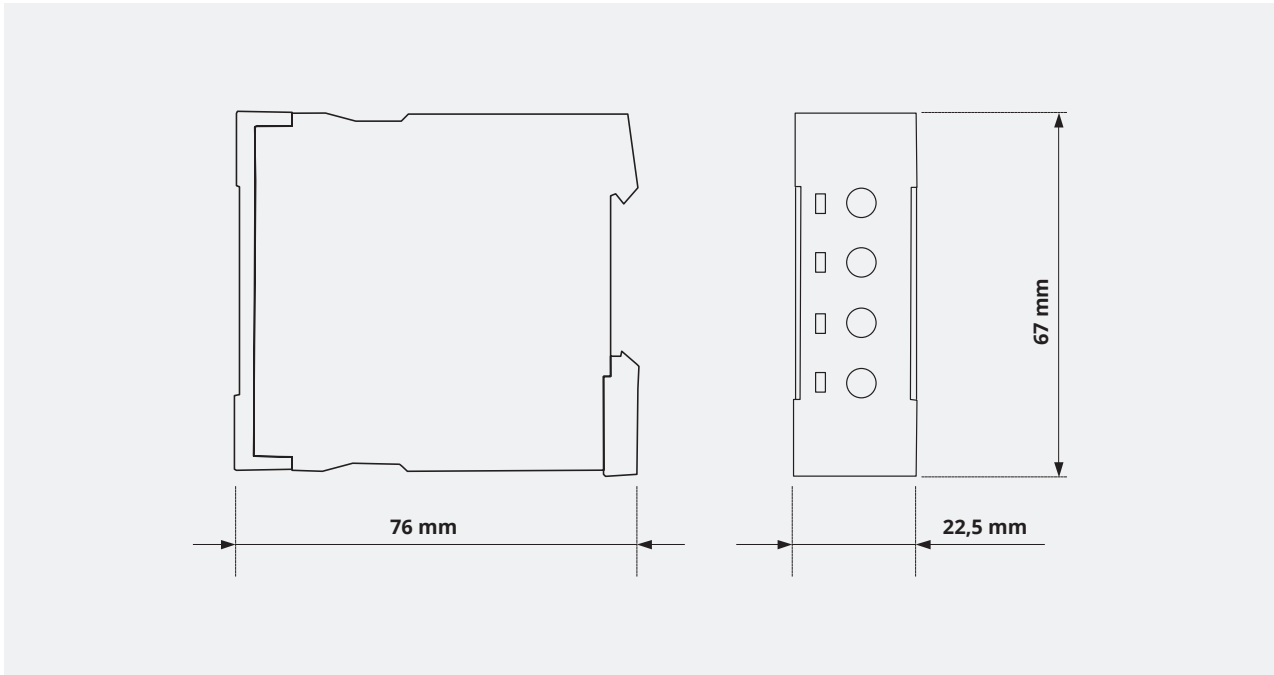



VEO

TIME RELAY / MULTIFUNCTION TIME RELAY

V2ZQ10 24-240V AC/DC

Art.Nr.: 125150

V2ZQ10P 24-240V AC/DC

Art.Nr.: 125650



- ✓ 4 functions
- ✓ 10 time ranges
- ✓ Supply voltage 24-240V AC/DC
- ✓ 1 change-over contact
- ✓ Width 22,5 mm

Control elements

- ✓ Fine adjustment
- ✓ Setting of time range
- ✓ Function selector

Status indication

- ✓ LED U/t: Supply voltage
- ✓ LED R: Relay status



TECHNICAL DATA

SUPPLY CIRCUIT

Terminals	A1-A2	
Supply voltage	24 ... 240 V AC/DC	
Supply voltage tolerance	-15 / +10%	
Rated frequency	50 / 60 Hz or DC	
Rated frequency tolerance	48 ... 63 Hz	
Rated consumption	230 V AC	typ. 0,4 W / 0,75 VA
	24 V DC	typ. 0,25 W / 0,25 VA
Standby consumption	230 V AC	typ. 0,16 W / 0,3 VA
	24 V DC	typ. 0,03 W / 0,09 VA
Duty-cycle	100%	
Backup power time	< 30 ms	
Recovery time	> 100 ms	
Drop-out voltage	≥ 15,5 V	

CONTROL INPUT

Terminals	A1-B1	
Function	start of function	
Type	voltage controlled	
Control voltage	see supply voltage	
Minimum control pulse length	AC	min. 50 ms
	DC	min. 25 ms
Loadable	yes	



VEO

TIME RELAY / MULTIFUNCTION TIME RELAY

V2ZQ10 24-240V AC/DC

Art.Nr.: 125150

V2ZQ10P 24-240V AC/DC

Art.Nr.: 125650



TIMING CIRCUIT

Time ranges	10	0,05 ... 1 s
		0,15 ... 3 s
		0,5 ... 10 s
		1,5 ... 30 s
		3 ... 60 s
		9 ... 180 s
		0,5 ... 10 min
		3 ... 60 min
		0,5 ... 10 h
		5 ... 100 h

RANGE OF FUNCTIONS

Functions	4	E, R, Wu, Bp
-----------	---	--------------

STATUS INDICATION

Supply voltage / time lapse	LED U/t (green) on	supply voltage applied
	LED U/t (green) flashes	indication of lapse of time
Relay status	LED R (yellow) on	output relay energized

OUTPUT CIRCUIT

Terminals		15-16-18
Kind of output		Relay
Number of contacts	change-over contact	1
Contact material		AgNi
Rated voltage (IEC 60947-5-1)		250 V
Maximum switching voltage		400 V AC
Minimum switching voltage / switching current		12 V / 10 mA
Rated current (IEC 60947-5-1)	AC-1	8 A / 250 V
	AC-15	1,5 A / 240 V (B300)
	DC-12	8 A / 24 V
	DC-13	0,1 A / 250 V
Endurance	mechanical	30 x 10 ⁶ switching cycles
	electrical (AC-1)	100 x 10 ³ switching cycles
Rated frequency of operation	with load	6/min
	without load	1200/min



VEO

TIME RELAY / MULTIFUNCTION TIME RELAY

V2ZQ10 24-240V AC/DC

Art.Nr.: 125150

V2ZQ10P 24-240V AC/DC

Art.Nr.: 125650



ACCURACY

Base accuracy	< 1 % (of full scale)
Setting accuracy	< 5 % (of full scale)
Repeat accuracy	< 0,5 % or ± 5 ms
Temperature influence	< 0,01 % / °C
Voltage influence	-
Frequency influence	-

ENVIRONMENTAL CONDITIONS

Ambient temperature	operation	-25 ... +60 °C
	storage	-40 ... +70 °C
Relative humidity		5 ... 95 %
Vibration	EN 61812-1	10 ... 60 Hz: 0,15 mm; 60 ... 150 Hz: 20 m/s ²
	EN 60947-1	2 ... 13,2 Hz: 1 mm; 13,2 ... 100 Hz: 7 m/s ²
Shock	EN 60947-1	± 150 m/s ² 11 ms

GENERAL DATA

Dimensions	W × H × D	22,5 × 67 × 76 mm
Mounting		DIN rail (EN60715)
Mounting position		any
Housing material		PA 66, self-extinguishing plastic, class V-0
Degree of protection	housing	IP40
	terminals	IP20
Electrical connection	V2ZQ10	Screw terminal
Wire size	flexible with wire end ferrule	0,5 ... 2,5 mm ² (20 AWG ... 13 AWG)
	flexible without wire end ferrule	0,5 ... 4 mm ² (20 AWG ... 12 AWG)
	rigid	0,5 ... 4 mm ² (20 AWG ... 12 AWG)
Stripping length		8 mm
Tightening torque		max. 1Nm
Electrical connection	V2ZQ10P	Push-in terminal
Wire size	flexible with wire end ferrule	0,25 ... 1,5 mm ² (24 AWG ... 16 AWG)
	flexible with plastic ferrule	0,25 ... 0,75 mm ² (24 AWG ... 19 AWG)
	flexible without wire end ferrule	0,2 ... 1,5 mm ² (24 AWG ... 16 AWG)
	rigid	0,2 ... 1,5 mm ² (24 AWG ... 16 AWG)
Stripping length		8 mm



VEO

TIME RELAY / MULTIFUNCTION TIME RELAY

V2ZQ10 24-240V AC/DC

Art.Nr.: 125150

V2ZQ10P 24-240V AC/DC

Art.Nr.: 125650



GENERAL DATA

Prospective current value	1000 A _{eff}
Fuse rating	8A fast acting
MTTF	-
Weight	85 g

ISOLATION DATA

Pollution degree (IEC 61812-1)	2
Overvoltage category (IEC 61812-1)	III
Rated insulation voltage (IEC 61812-1)	supply circuit / output circuit 300 V
Rated impulse withstanding voltage (IEC 61812-1)	supply circuit / output circuit 6 kV
Insulation test voltage (IEC 61812-1)	supply circuit / output circuit 3200 V
Degree of protection	supply circuit / output circuit protective separation

STANDARDS

Product standard	IEC 61812-1
Interference immunity	IEC 61812-1 class A
Interference emission	IEC 61812-1 class A
Approvals	



VEO

TIME RELAY / MULTIFUNCTION TIME RELAY

V2ZQ10 24-240V AC/DC

Art.Nr.: 125150

V2ZQ10P 24-240V AC/DC

Art.Nr.: 125650



FUNKTIONEN

ON delay (E)

When the supply voltage U is applied, the set interval t begins (green LED U/t flashes). After the interval t has expired (green LED U/t illuminated) the output relay R switches into on-position (yellow LED illuminated). This status remains until the supply voltage is interrupted. If the supply voltage is interrupted before the expiry of the interval t, the interval already expired is erased and is restarted when the supply voltage is next applied.

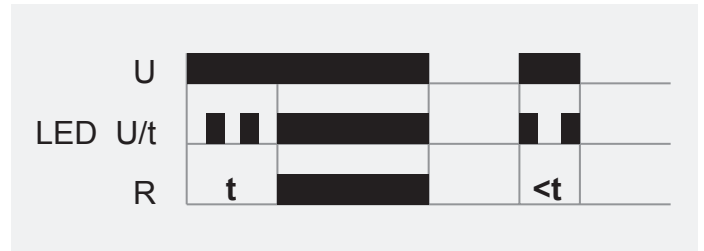

OFF delay with control input (R)

The supply voltage U must be constantly applied to the device (green LED U/t illuminated). When the control contact S is closed, the output relay R switches into on-position (yellow LED illuminated). If the control contact is opened, the set interval t begins (green LED U/t flashes). After the interval t has expired (green LED U/t illuminated) the output relay switches into off-position (yellow LED not illuminated). If the control contact is closed again before the interval t has expired, the interval already expired is erased and is restarted.

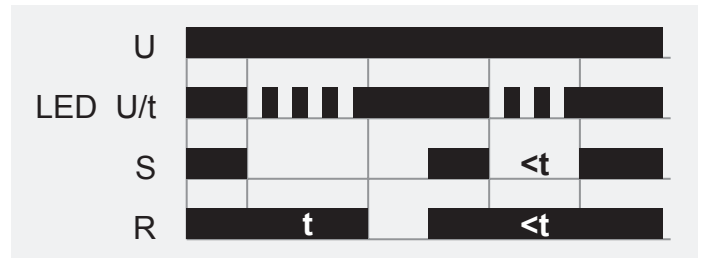

Single shot leading edge voltage controlled (Wu)

When the supply voltage U is applied, the output relay R switches into on-position (yellow LED illuminated) and the set interval t begins (green LED U/t flashes). After the interval t has expired (green LED U/t illuminated) the output relay switches into off-position (yellow LED not illuminated). This status remains until the supply voltage is interrupted. If the supply voltage is interrupted before the interval t has expired, the output relay switches into off-position. The interval already is erased and is restarted when the supply voltage is next applied.

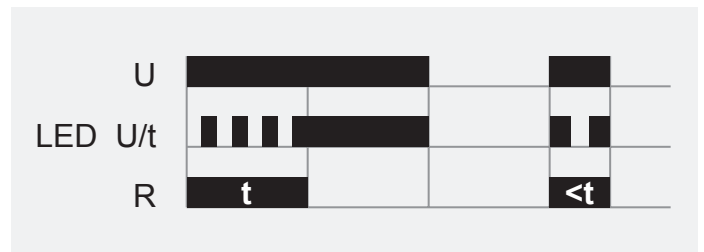

Flasher pause first (Bp)

When the supply voltage U is applied, the set interval t begins (green LED U/t flashes). After the interval t has expired, the output relay R switches into on-position (yellow LED illuminated) and the set interval t begins again. After the interval t has expired, the output relay switches into off-position (yellow LED not illuminated). The output relay is triggered at a ratio of 1:1 until the supply voltage is interrupted.

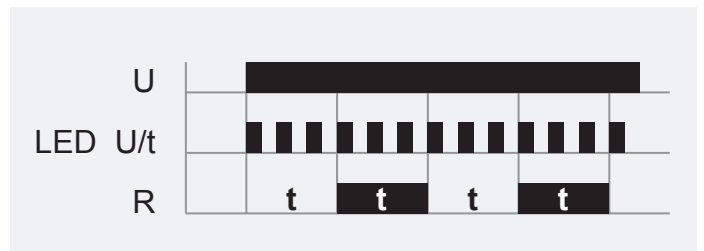



VEO

TIME RELAY / MULTIFUNCTION TIME RELAY

V2ZQ10 24-240V AC/DC

Art.Nr.: 125150

V2ZQ10P 24-240V AC/DC

Art.Nr.: 125650



CONNECTIONS

without control input

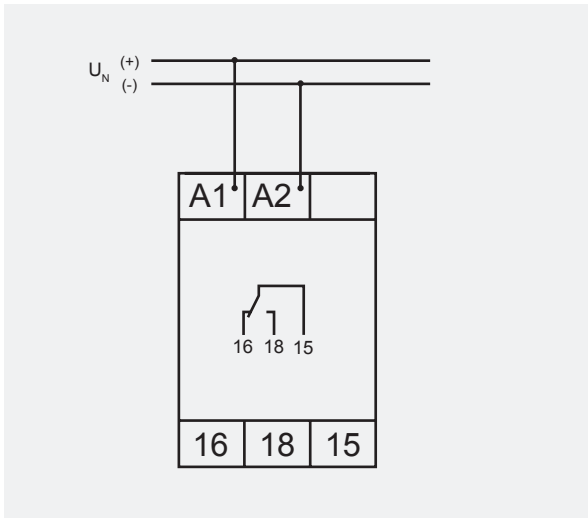

with control input

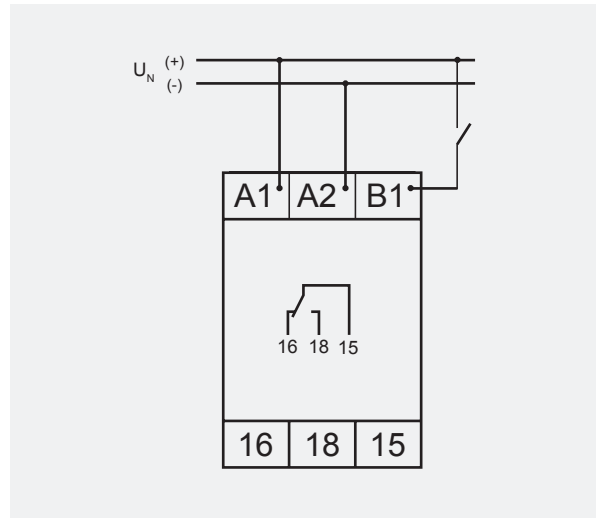

DIMENSIONS

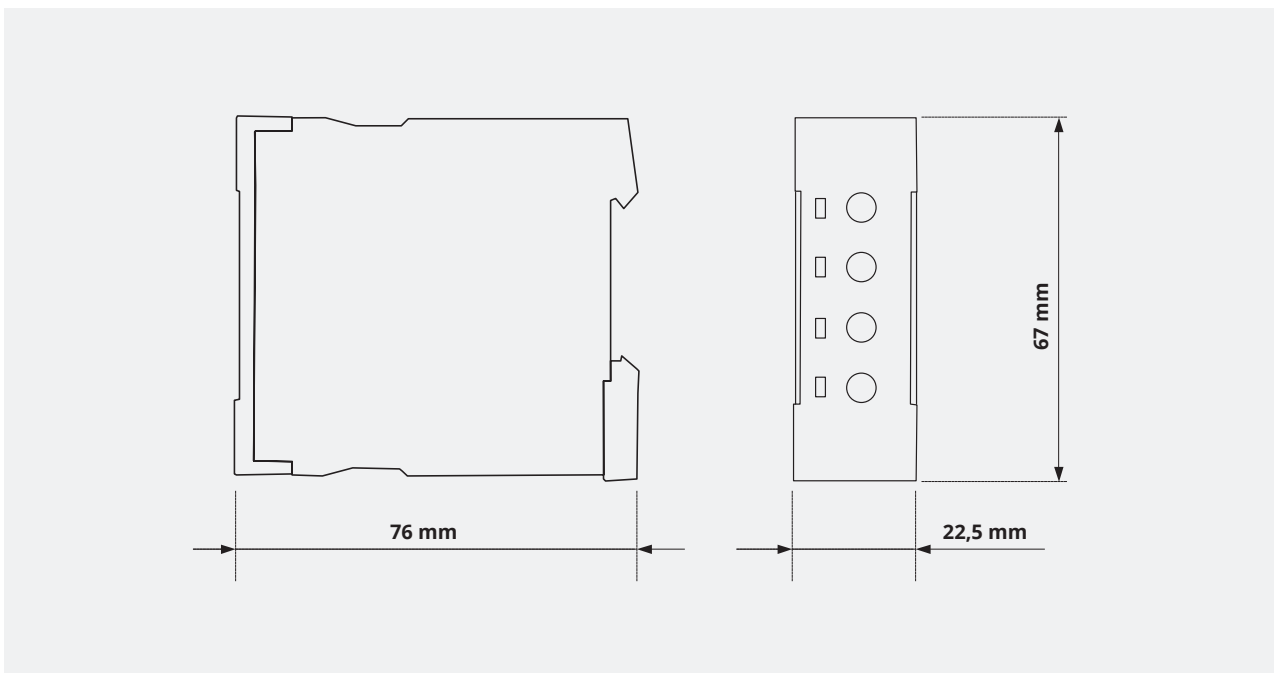



VEO

TIME RELAY / MULTIFUNCTION TIME RELAY

V2ZM10-A 12-240V AC/DC

Art.Nr.: 125101A



- ✓ 10 functions
- ✓ 10 time ranges
- ✓ Supply voltage 12-240 V AC/DC
- ✓ 1 change-over contact
- ✓ Width 22.5mm

Control elements

- ✓ Fine adjustment
- ✓ Setting of time range
- ✓ Function selector

Status indication

- ✓ LED U/t: Supply voltage
- ✓ LED R: Relay status



TECHNICAL DATA

SUPPLY CIRCUIT

Terminals	A1-A2	
Supply voltage	12 ... 240V AC/DC	
Supply voltage tolerance	-10 / +10 %	
Rated frequency	50 / 60Hz or DC	
Rated frequency tolerance	48 ... 63Hz	
Rated consumption	230 V AC	typ. 0,4 W / 0,75 VA
	24 V DC	typ. 0,25 W / 0,25 VA
Standby consumption	230 V AC	typ. 0,16 W / 0,3 VA
	24 V DC	typ. 0,03 W / 0,09 VA
Duty-cycle	100%	
Backup power time	< 30 ms	
Recovery time	> 100 ms	
Drop-out voltage	≥ 7 V	

CONTROL INPUT

Terminals	A1-B1	
Function	start of function	
Type	voltage controlled	
Control voltage	see supply voltage	
Minimum control pulse length	AC	min. 50 ms
	DC	min. 25 ms
Loadable	yes	



VEO

TIME RELAY / MULTIFUNCTION TIME RELAY

V2ZM10-A 12-240V AC/DC

Art.Nr.: 125101A



TIMING CIRCUIT

Time ranges	10	0,05 ... 1 s
		0,15 ... 3 s
		0,5 ... 10 s
		1,5 ... 30 s
		3 ... 60 s
		9 ... 180 s
		0,5 ... 10 min
		3 ... 60 min
		0,5 ... 10 h
		5 ... 100 h

RANGE OF FUNCTIONS

Functions	10	E, R, EWu, Es, Ws, Wa, Ec, Bp, Bi, Wt
-----------	----	---------------------------------------

STATUS INDICATION

Supply voltage / time lapse	LED U/t (green) on	supply voltage applied
	LED U/t (green) flashes	indication of lapse of time
Relay status	LED R (yellow) on	output relay energized

OUTPUT CIRCUIT

Terminals		15-16-18
Kind of output		Relay
Number of contacts	change-over contact	1
Contact material		AgNi
Rated voltage (IEC 60947-5-1)		250V
Maximum switching voltage		400V AC
Minimum switching voltage / switching current		12 V / 10 mA
Rated current (IEC 60947-5-1)	AC-1	8 A / 250 V
	AC-15	1,5 A / 240 V (B300)
	DC-12	8 A / 24 V
	DC-13	0,1 A / 250 V
Endurance	mechanical	30 x 10 ⁶ switching cycles
	electrical (AC-1)	100 x 10 ³ switching cycles
Rated frequency of operation	with load	6/min
	without load	1200/min



VEO

TIME RELAY / MULTIFUNCTION TIME RELAY

V2ZM10-A 12-240V AC/DC

Art.Nr.: 125101A



ACCURACY

Base accuracy	< 1 % (of full scale)
Setting accuracy	< 5 % (of full scale)
Repeat accuracy	< 0,5 % or ± 5 ms
Temperature influence	< 0,01 % / °C
Voltage influence	-
Frequency influence	-

ENVIRONMENTAL CONDITIONS

Ambient temperature	operation	-25 ... +60°C
	storage	-40 ... +70°C
Relative humidity		5 ... 95 %
Vibration	EN 61812-1	10 ... 60 Hz: 0,15 mm; 60 ... 150 Hz: 20 m/s ²
	EN 60947-1	2 ... 13,2 Hz: 1 mm; 13,2 ... 100 Hz: 7 m/s ²
Shock	EN 60947-1	± 150 m/s ² 11 ms

GENERAL DATA

Dimensions	W × H × D	22,5 × 67 × 76 mm
Mounting		DIN rail (EN60715)
Mounting position		any
Housing material		PA 66, self-extinguishing plastic, class V-0
Degree of protection	housing	IP40
	terminals	IP20
Electrical connection	V2ZM10-A	Screw terminal
Wire size	flexible with wire end ferrule	0,5 ... 2,5 mm ² (20 AWG ... 13 AWG)
	flexible without wire end ferrule	0,5 ... 4 mm ² (20 AWG ... 12 AWG)
	rigid	0,5 ... 4 mm ² (20 AWG ... 12 AWG)
Stripping length		8 mm
Tightening torque		max. 1Nm
Prospective current value		1000 A _{eff}
Fuse rating		8A fast acting
MTTF		-
Weight		85 g



VEO

TIME RELAY / MULTIFUNCTION TIME RELAY

V2ZM10-A 12-240V AC/DC

Art.Nr.: 125101A



ISOLATION DATA

Pollution degree (IEC 61812-1)		2
Overvoltage category (IEC 61812-1)		III
Rated insulation voltage (IEC 61812-1)	supply circuit / output circuit	300 V
Rated impulse withstanding voltage (IEC 61812-1)	supply circuit / output circuit	6 kV
Insulation test voltage (IEC 61812-1)	supply circuit / output circuit	3200 V
Degree of protection	supply circuit / output circuit	protective separation

STANDARDS

Product standard		IEC 61812-1
Interference immunity	IEC 61812-1	class A
Interference emission	IEC 61812-1	class A
Approvals		



VEO

TIME RELAY / MULTIFUNCTION TIME RELAY

V2ZM10-A 12-240V AC/DC

Art.Nr.: 125101A



FUNCTIONS

ON delay (E)

When the supply voltage U is applied, the set interval t begins (green LED U/t flashes). After the interval t has expired (green LED U/t illuminated) the output relay R switches into on-position (yellow LED illuminated). This status remains until the supply voltage is interrupted before the expiry of the interval t, the interval already expired is erased and is restarted when the supply voltage is next applied.

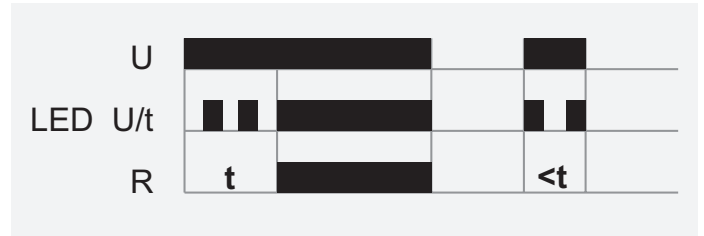

OFF delay with control input (R)

The supply voltage U must be constantly applied to the device (green LED U/t illuminated). When the control contact S is closed, the output relay R switches into on-position (yellow LED illuminated). If the control contact is opened, the set interval t begins (green LED U/t flashes). After the interval t has expired (green LED U/t illuminated) the output relay switches into off-position (yellow LED not illuminated). If the control contact is closed again before the interval t has expired, the interval already expired is erased and is restarted.

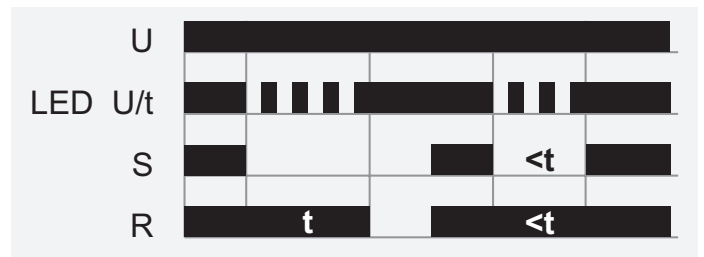

Single shot leading edge with control input (Ws)

The supply voltage U must be constantly applied to the device (green LED U/t illuminated). When the control contact S is closed, the output relay R switches into on-position (green LED U/t illuminated) and the set interval t begins (green LED U/t flashes). After the interval t has expired (green LED U/t illuminated) the output relay switches into off-position (yellow LED not illuminated). During the interval, the control contact can be operated any number of times. A further cycle can only be started when the cycle run has been completed.

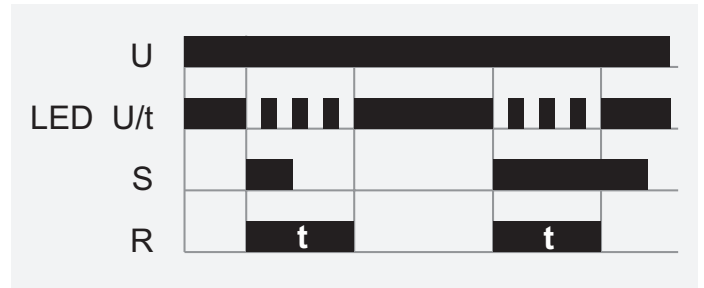

ON delay single shot leading edge voltage controlled (EWu)

When the supply voltage U is applied, the set interval t_1 begins (green LED U/t flashes slowly). After the interval t_1 has expired, the output relay R switches into on-position (yellow LED R illuminated) and the fixed interval t_2 (=1 s) begins (green LED U/t flashes fast). After the interval t_2 has expired, the output relay switches into off-position (yellow LED R not illuminated). If the supply voltage is interrupted before the interval t_1+t_2 has expired, the interval already expired is erased and is restarted when the supply voltage is next applied.

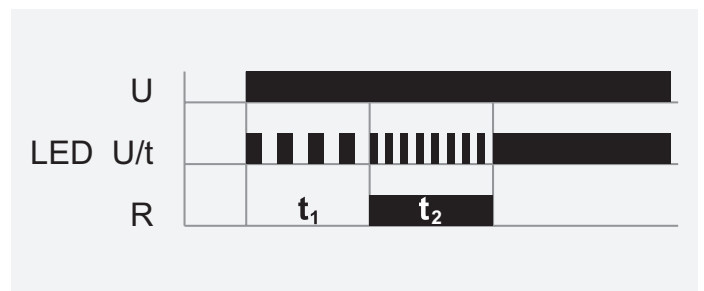

Single shot trailing edge with control input (Wa)

The supply voltage U must be constantly applied to the device (green LED U/t illuminated). Closing the control contact S has no influence on the condition of the output R. When the control contact is opened, the output relay switches into on-position (yellow LED illuminated) and the set interval t begins (green LED U/t flashes). After the interval t has expired (green LED U/t illuminated), the output relay switches into off-position (yellow LED not illuminated). During the interval, the control contact can be operated any number of times. A further cycle can only be started when the cycle run has been completed.

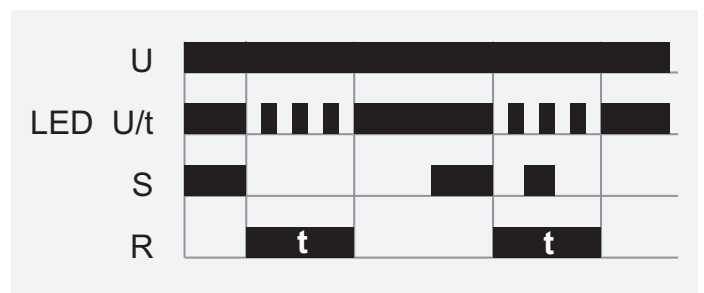



VEO

TIME RELAY / MULTIFUNCTION TIME RELAY

V2ZM10-A 12-240V AC/DC

Art.Nr.: 125101A



FUNCTIONS

ON delay with control input (Es)

The supply voltage U must be constantly applied to the device (green LED U/t illuminated). When the control contact S is closed, the set interval t begins (green LED U/t flashes). After the interval t has expired (green LED U/t illuminated) the output relay R switches into on-position (yellow LED illuminated). This status remains until the control contact is opened again. If the control contact is opened before the interval t has expired, the interval already expired is erased and is restarted with the next cycle.

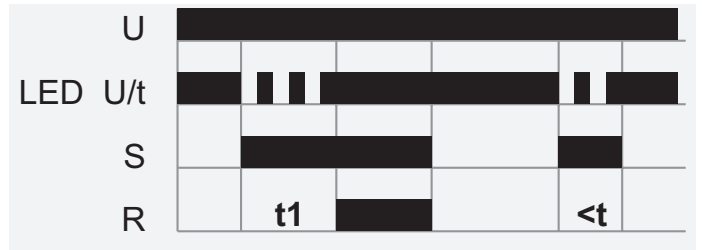

Flasher pause first (Bp)

When the supply voltage U is applied, the set interval t begins (green LED U/t flashes). After the interval t has expired, the output relay R switches into on-position (yellow LED illuminated) and the set interval t begins again. After the interval t has expired, the output relay switches into off-position (yellow LED not illuminated). The output relay is triggered at a ratio of 1:1 until the supply voltage is interrupted.

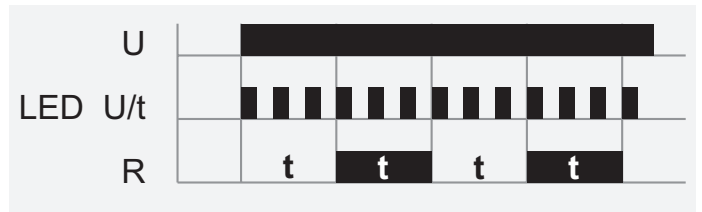

Flasher pulse first (Bi)

When the supply voltage U is applied, the output relay R switches into on-position (yellow LED illuminated) and the set interval t begins (green LED U/t flashes). After the interval t has expired, the output relay R switches into off-position (yellow LED not illuminated) and the set interval t begins again (green LED U/t flashes). The output relay is triggered at a ratio of 1:1 until the supply voltage is interrupted.

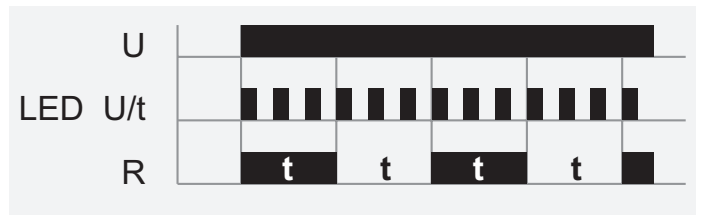

Pulse sequence monitoring (Wt)

When the supply voltage U is applied (green LED U/t illuminated), the output relay R switches into on-position (yellow LED illuminated). When the control contact S is closed, the set interval t begins (green LED U/t flashes). So that the output relay R remains in on-position, the control contact S must be opened and closed again within the set interval t . If this does not happen, the output relay R switches into off-position and all further pulses at the control contact are ignored. To restart the function the supply voltage must be interrupted and re-applied.

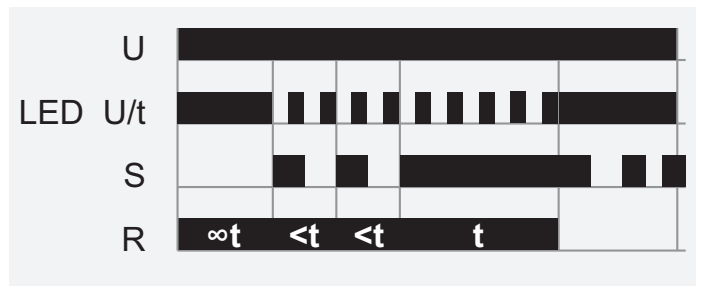

Additive ON Delay (Ec)

When the supply voltage U is applied, the release for the interval starts (green LED U/t illuminated). When the control contact S is closed, the set interval t begins (green LED U/t flashes). If the control contact S is opened during the set interval t , the interval stops (green LED U/t illuminated), and the already expired interval is stored. During the lapse of time the control contact can be opened or closed as often as required. If the sum of the periods, in which the control contact S is closed reaches the set interval t the output relay R switches into on-position (yellow LED R illuminated). The interval is stopped (green LED U/t illuminated) and a further activation of the control contact S remains without effect. By interrupting the supply voltage, the device will be reset. A possibly expired time t is deleted.

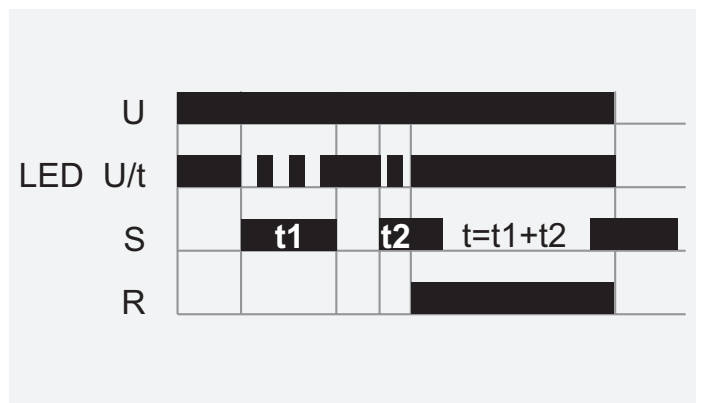



CONNECTIONS

without control input

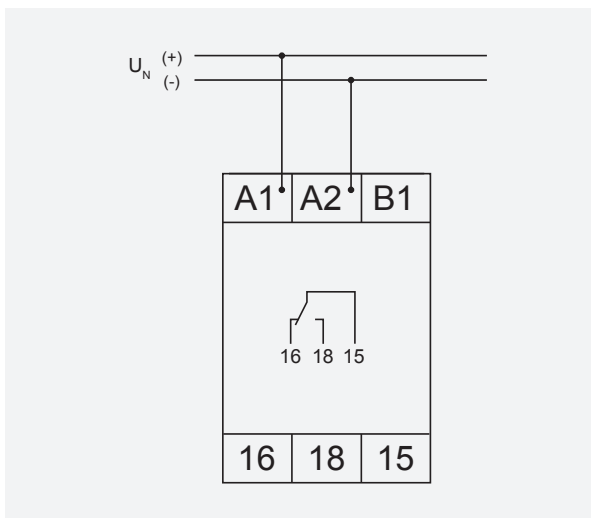

with control input

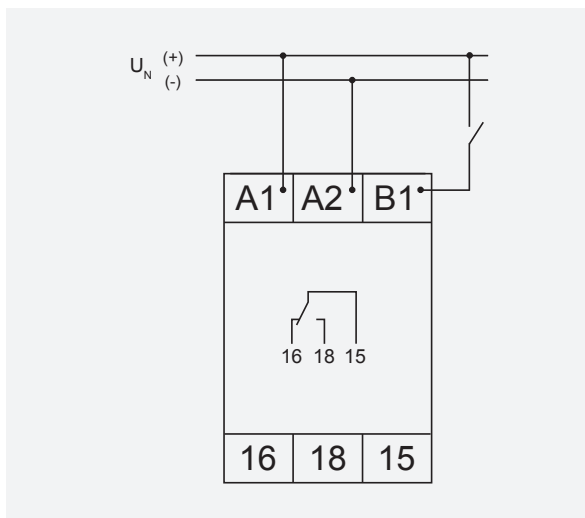

DIMENSIONS

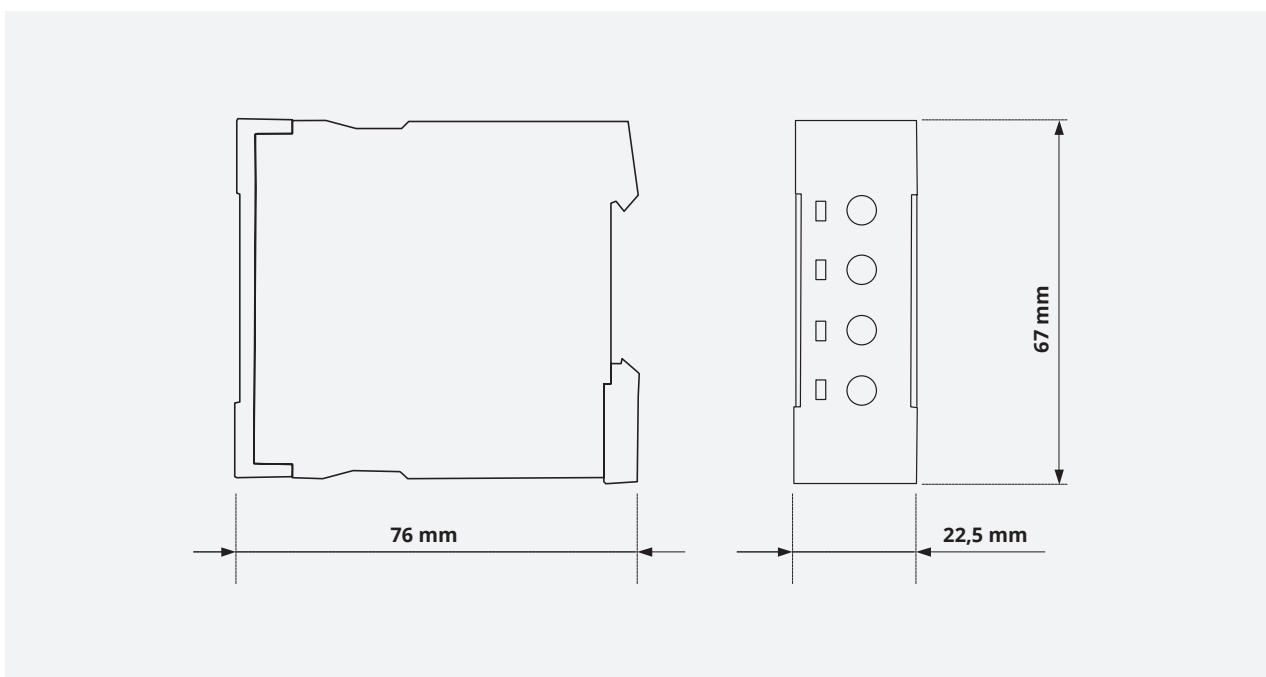



VEO

TIME RELAY / STAR-DELTA-TIMER

V2ZS20 12-240V AC/DC

Art.Nr.: 125300

V2ZS20P 12-240V AC/DC

Art.Nr.: 125310



- ✓ 4 time ranges
- ✓ 4 transition times
- ✓ Supply voltage 12-240V AC/DC
- ✓ 2 normally open contacts
- ✓ Width 22,5 mm

Control elements

- ✓ Fine adjustment star contactor
- ✓ Setting of time range star contactor
- ✓ Transit time

Status indication

- ✓ LED U/t: Time lapse star / delta contactor
- ✓ LED R: Relay status



TECHNICAL DATA

SUPPLY CIRCUIT

Terminals	A1-A2	
Supply voltage	12 ... 240 V AC/DC	
Supply voltage tolerance	-10 / +10 %	
Rated frequency	50 / 60 Hz or DC	
Rated frequency tolerance	48 ... 63 Hz	
Rated consumption	230 V AC	typ. 0,3 W / 0,5 VA
	24 V DC	typ. 0,18 W / 0,2 VA
Duty-cycle	100%	
Backup power time	< 30 ms	
Recovery time	> 200 ms	
Drop-out voltage	≥ 7 V	

TIMING CIRCUIT

Time ranges	4	0,5 ... 10 s
		1,5 ... 30 s
		3 ... 60 s
		9 ... 180 s
	4	40 ms
		60 ms
		80 ms
		100 ms



VEO

TIME RELAY / STAR-DELTA-TIMER

V2ZS20 12-240V AC/DC

Art.Nr.: 125300

V2ZS20P 12-240V AC/DC

Art.Nr.: 125310



RANGE OF FUNCTIONS

Functions	1	S
-----------	---	---

STATUS INDICATION

Supply voltage / time lapse	LED U/t (green) flashes	star contactor is active
	LED U/t (green) on	delta contactor is active
Relay status	LED R (yellow) on	star contactor is active

OUTPUT CIRCUIT

Terminals	17-18-28	
Kind of output	Relay	
Number of contacts	normally open contact	2
Contact material	AgNi	
Rated voltage (IEC 60947-5-1)	250 V	
Maximum switching voltage	277 V AC	
Minimum switching voltage / switching current	12 V / 10 mA	
Rated current (IEC 60947-5-1)	AC-1	3 A / 250 V
	AC-15	0,75 A / 240 V (C300)
	DC-12	5 A / 24 V
	DC-13	0,1 A / 250 V
Endurance	mechanical	20 x 10 ⁶ switching cycles
	electrical (AC-1)	100 x 10 ³ switching cycles
Rated frequency of operation	with load	6/min
	without load	1200/min

ACCURACY

Base accuracy	< 1 % (of full scale)
Setting accuracy	< 5 % (of full scale)
Repeat accuracy	< 0,5 % or ±5 ms
Temperature influence	< 0,01 % / °C
Voltage influence	-
Frequency influence	-



VEO

TIME RELAY / STAR-DELTA-TIMER

V2ZS20 12-240V AC/DC

Art.Nr.: 125300

V2ZS20P 12-240V AC/DC

Art.Nr.: 125310



ENVIRONMENTAL CONDITIONS

Ambient temperature	operation	-25 ... +60 °C
	storage	-40 ... +70 °C
Relative humidity		5 ... 95 %
Vibration	EN 61812-1	10 ... 60 Hz: 0,15 mm; 60 ... 150 Hz: 20 m/s ²
	EN 60947-1	2 ... 13,2 Hz: 1 mm; 13,2 ... 100 Hz: 7 m/s ²
Shock	EN 60947-1	±150 m/s ² 11 ms

GENERAL DATA

Dimensions	W × H × D	22,5 × 67 × 76 mm
Mounting		DIN rail (EN60715)
Mounting position		any
Housing material		PA 66, self-extinguishing plastic, class V-0
Degree of protection	housing	IP40
	terminals	IP20
Electrical connection	V2ZS20	Screw terminal
Wire size	flexible with wire end ferrule	0,5 ... 2,5 mm ² (20 AWG ... 13 AWG)
	flexible without wire end ferrule	0,5 ... 4 mm ² (20 AWG ... 12 AWG)
	rigid	0,5 ... 4 mm ² (20 AWG ... 12 AWG)
Stripping length		8 mm
Tightening torque		max. 1Nm
Electrical connection	V2ZS20P	Push-in terminal
Wire size	flexible with wire end ferrule	0,25 ... 1,5 mm ² (24 AWG ... 16 AWG)
	flexible with plastic ferrule	0,25 ... 0,75 mm ² (24 AWG ... 19 AWG)
	flexible without wire end ferrule	0,2 ... 1,5 mm ² (24 AWG ... 16 AWG)
	rigid	0,2 ... 1,5 mm ² (24 AWG ... 16 AWG)
Stripping length		8 mm
Prospective current value		1000 A _{Eff}
Fuse rating		5A fast acting
MTTF		-
Weight		82 g

ISOLATION DATA

Pollution degree (IEC 61812-1)		2
Overvoltage category (IEC 61812-1)		III



VEO

TIME RELAY / STAR-DELTA-TIMER

V2ZS20 12-240V AC/DC

Art.Nr.: 125300

V2ZS20P 12-240V AC/DC

Art.Nr.: 125310



ISOLATION DATA

Rated insulation voltage (IEC 61812-1)	supply circuit / output circuit	300 V
Rated impulse withstanding voltage (IEC 61812-1)	supply circuit / output circuit	4 kV
Insulation test voltage (IEC 61812-1)	supply circuit / output circuit	1600 V
Insulation	supply circuit / output circuit	protective separation

STANDARDS

Product standard	IEC 61812-1	
Interference immunity	IEC 61812-1	class A
Interference emission	IEC 61812-1	class A
Approvals		

FUNCTIONS

Star-Delta start-up (S)

When the supply voltage U is applied, the star-contact switches into onposition (yellow LED illuminated) and the set star-time t1 begins (green LED flashing). After the interval t1 has expired (green LED illuminated) the star-contact switches into off-position (yellow LED not illuminated) and the set transit-time t2 begins. After the interval t2 has expired the delta-contact switches into on-position. To restart the function the supply voltage must be interrupted and re-applied.

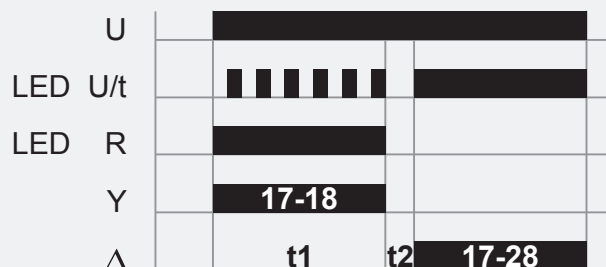



VEO

TIME RELAY / STAR-DELTA-TIMER

V2ZS20 12-240V AC/DC

Art.Nr.: 125300

V2ZS20P 12-240V AC/DC

Art.Nr.: 125310



CONNECTIONS

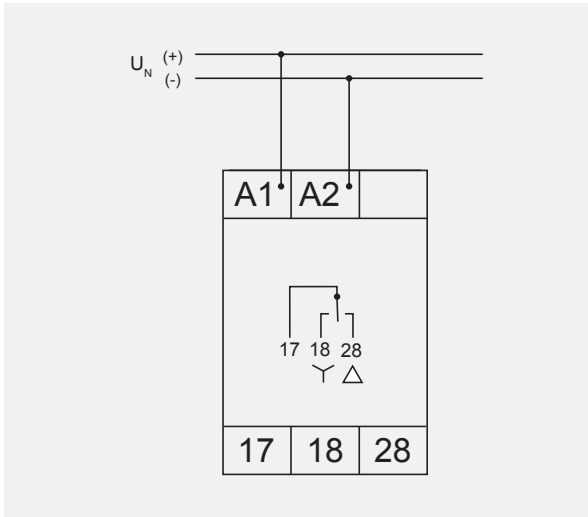

DIMENSIONS

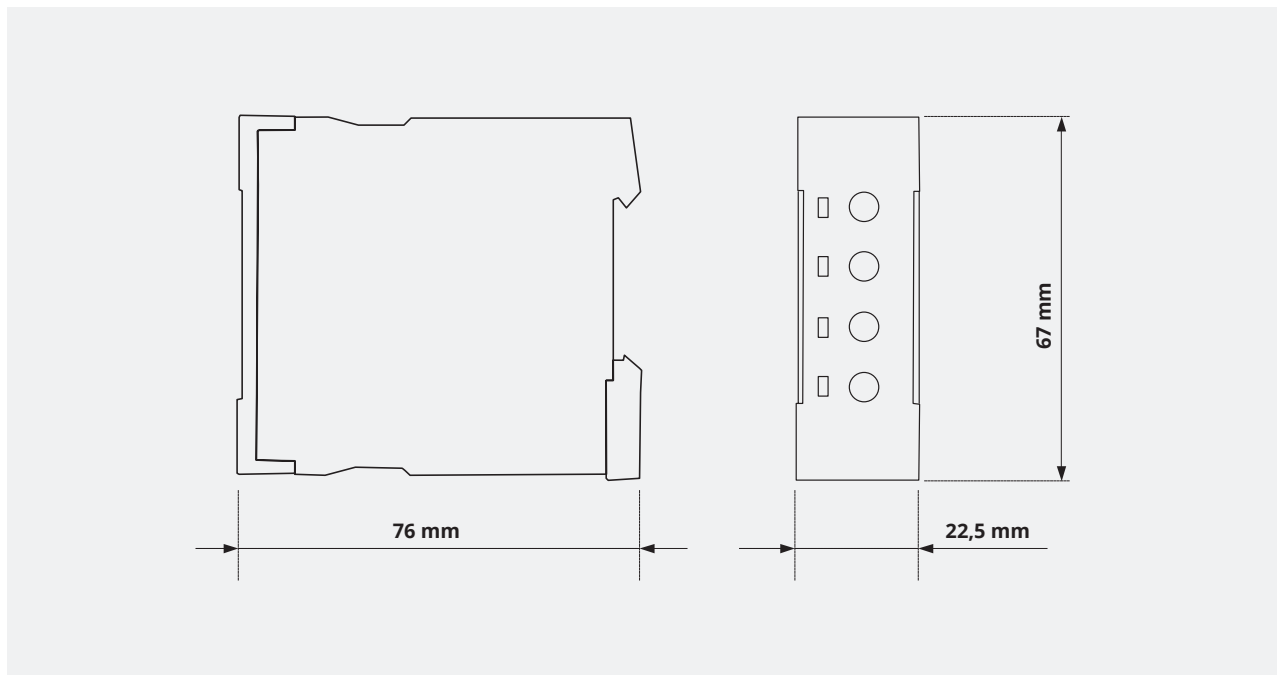

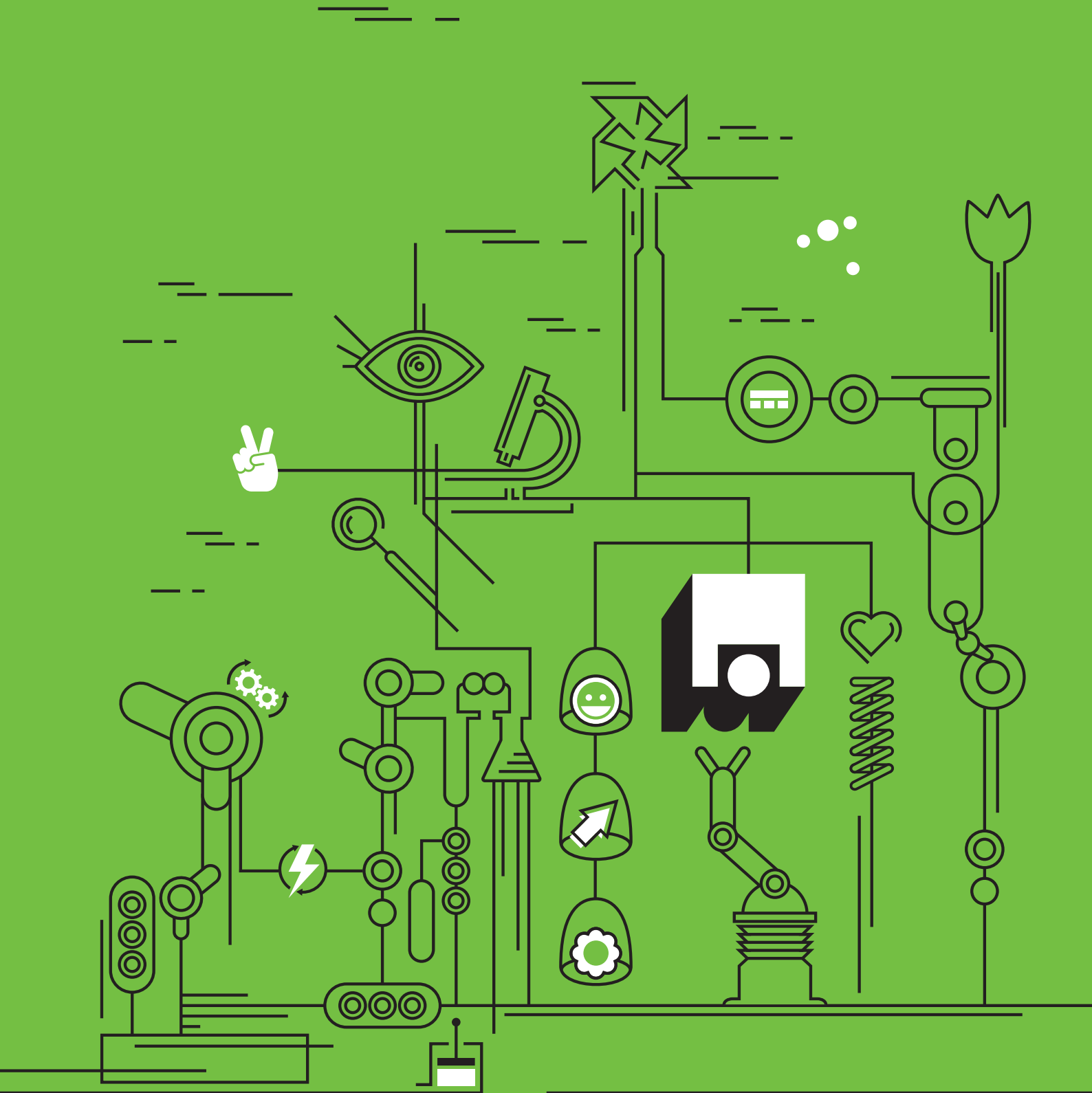

For contact data of your local distributor please visit
<http://www.tele-online.com/en/organization/distribution/>

Art.nr.: 091113/V3



tele

TELE Haase Steuergeraete Ges.m.b.H.

Vorarlberger Allee 38
Vienna, 1230
Austria

Phone +43 1 614 74-400
Email sales@tele-haase.at



MTO
electric a/s

Stiftsvej 14 | 7100 Vejle | Tlf. 75 800 310 | Fax 75 800 320 | info@mto-electric.dk | www.mto-electric.dk

