

els

Monitoring & Access Control Systems

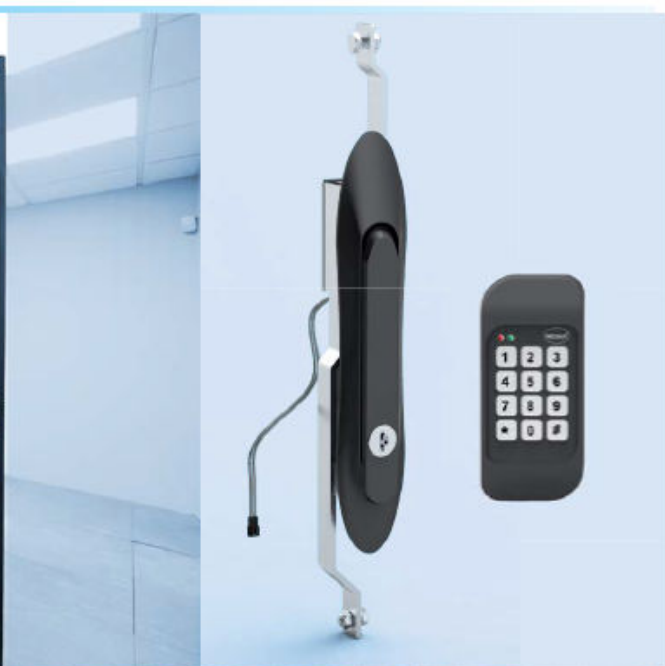

High security electronic products to protect your organisation's data

Præstmark A/S - Tel. 3888 4400
www.praestmark.dk



MONITORING & ACCESS CONTROL CONCEPT

The security of IT cabinets in server rooms and data centers is becoming more important world-wide. The reason is that a typical IT infrastructure supports the entire organization and stores the know-how of the company.

We have developed an integrated access control system called ELS. This new system enables you to monitor and control your IT environment in a very efficient way. Sensors detect door access, variations in temperature, security and other variables to give you immediate notification and greater control over your network, all at great value.

Cabinet doors can be opened by RFID cards, a key pad or remote control units. This solution manages who can open which cabinet doors and when and allows you to get a detailed report for each cabinet.

Basic features

- Provides environmental monitoring, access control and management system.
- Prevents unauthorized access.
- Allows doors to be opened using a proximity card, keypad or via a web interface.
- Accommodates sensors to monitor temperature, humidity, smoke, presence of water or liquids, etc.
- Automatically generates an audio alert.
- Records all the security information you need every time the door to a server cabinet is opened – who, where, when.

Applications

- Server cabinets in data centres
- Electric panels
- Telecommunications
- Kiosks



High security electronic products to protect your organisation's data

els



SYSTEM OVERVIEW

Simply add modules as your networks grows:

a single network connection provides access to up to 32 ACUs and controls access to them.

- ◆ Up to 32 ACUs can be linked together and controlled by just one MCU.
- ◆ IP monitoring of environmental conditions in the rack cabinet.
- ◆ Control of physical access to the rack cabinet.
- ◆ User interface is via proximity card reader or keypad.
- ◆ Electronic lock authorizes access.

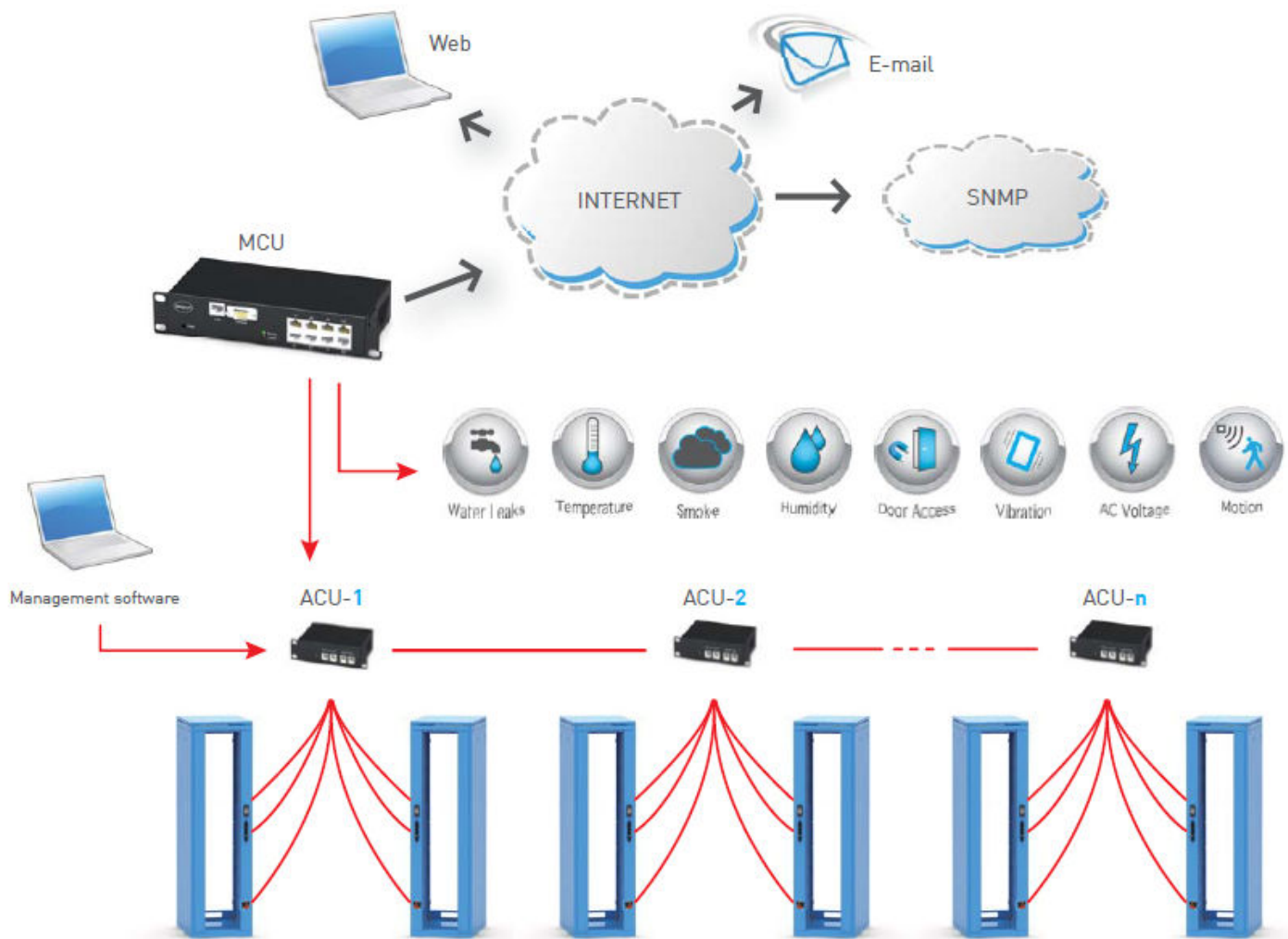

AI: Access Interface
ACU: Access Control Unit
MCU: Main Control Unit

Applications / STAND ALONE

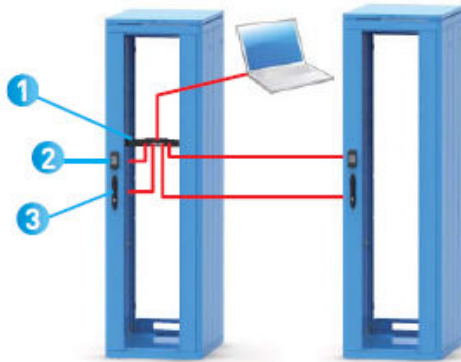

- Control of physical access to the rack cabinet
- User database
- Integrates with electronic locks supplied by Mesan
- Management software
- Option of proximity reader and / or keypad
- A sensor for detecting the state of the door (open / closed) can be connected

Applications / NETWORK 1

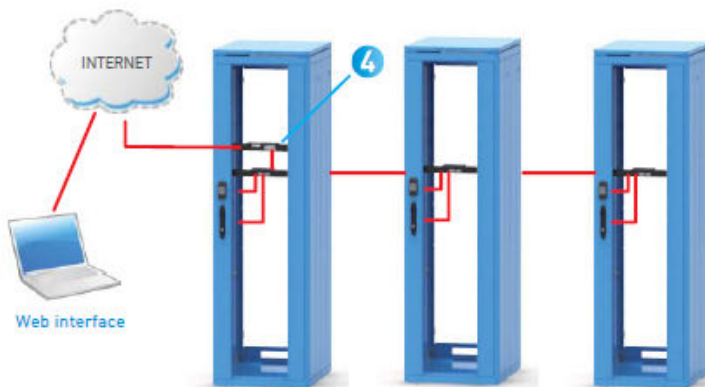

- The main control unit is an IP based solution for monitoring environmental conditions in and access to the rack cabinet
- Up to 32 ACUs can be controlled by just one MCU

Applications / NETWORK 2

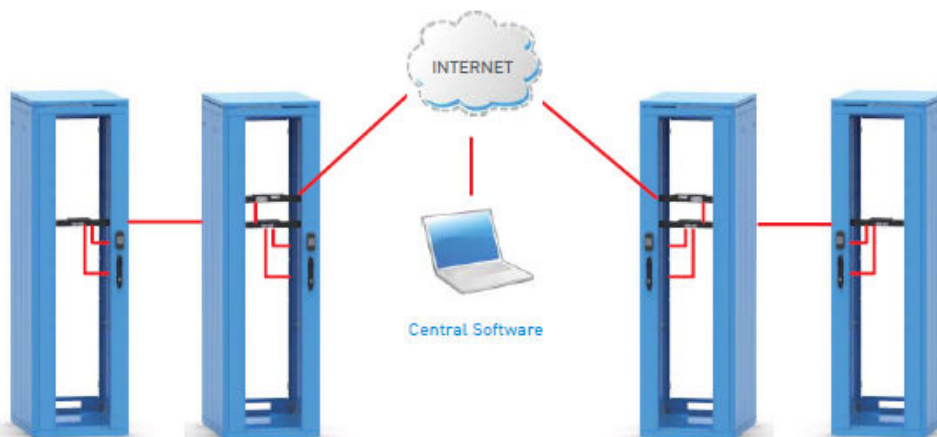

Access Control Unit



Access Interface Keypad



Electronic Swing Handle



Main Control Unit

Electronic Swing Handle with Gear Box

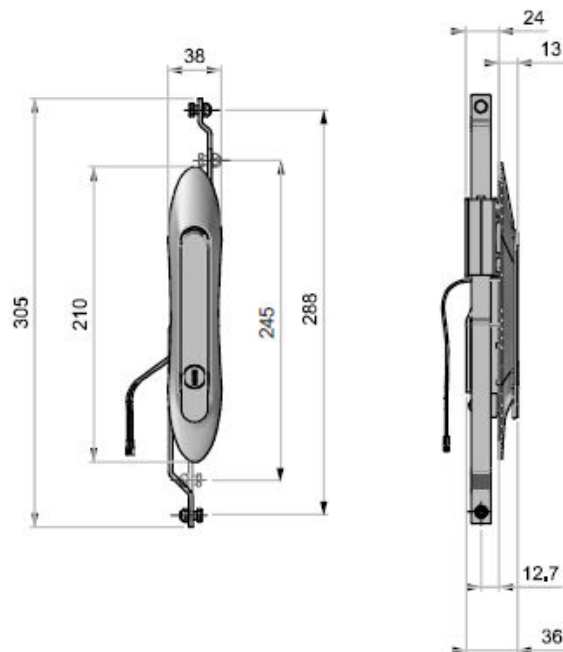

Specifications

- Swing handle for rack cabinets.
- Can be opened mechanically in the event of failure of the electronic system.
- Operates ± 5 V DC.
- Can be connected to the monitoring system via a cable.

Material:

BODY : Zamak DIN-EN 1774-ZnAl4Cu1
 HANDLE : Zamak DIN-EN 1774-ZnAl4Cu1
 MECHANISM : Zamak DIN-EN 1774-ZnAl4Cu1
 CAM : Steel
 SEAL : Polyurethane

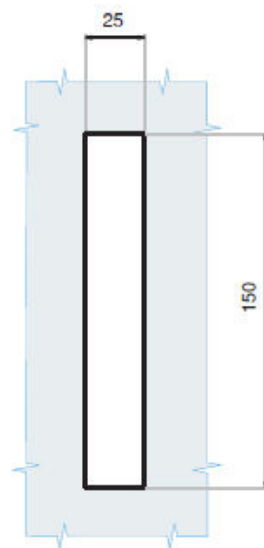

Cut Out

Product Code:

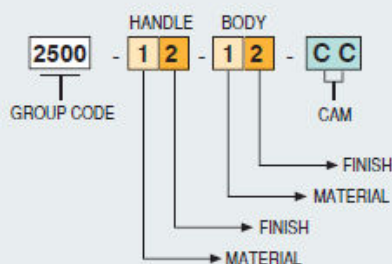

↔ For cams and rods please visit our website or see our catalogue

Electronic Swing Handle

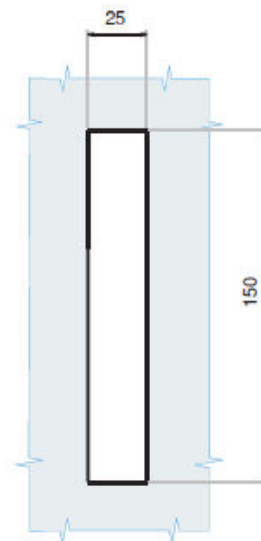
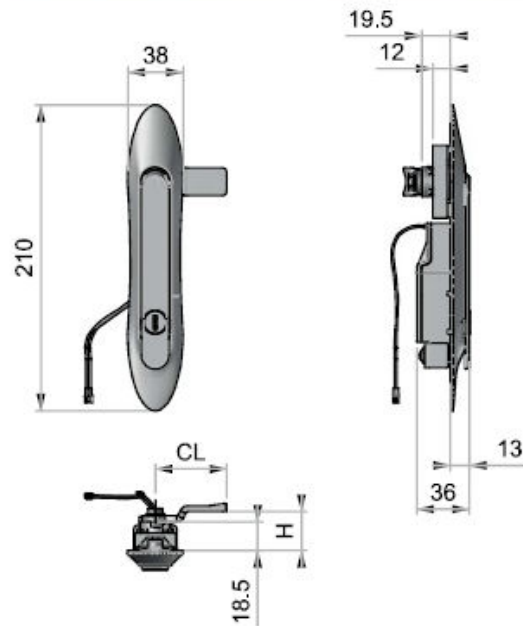

Cut Out

Specifications

- Swing handle for rack cabinets.
- Can be opened mechanically in the event of failure of the electronic system.
- Operates ± 5 V DC.
- Can be connected to the monitoring system via a cable.

Material:

- BODY : Zamak DIN-EN 1774-ZnAl4Cu1
- HANDLE : Zamak DIN-EN 1774-ZnAl4Cu1
- CAM : Steel
- SEAL : Polyurethane

Product Code:

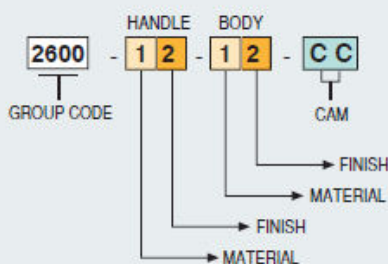

↪ For cams and rods please visit our website or see our catalogue

Main Control Unit (MCU)



The standalone Remote Control Unit is an intelligent device for monitoring environmental variations, such as temperature, humidity, smoke, presence of water or liquids, etc. When a sensor goes out of range of a configurable threshold, the unit will notify you via the web, e-mail or network management (SNMP).

Basic features

- Monitors and manages environmental and security conditions over IP
- Built-in web interface for monitoring and configuring the unit
- Creates alert with customized input parameters
- Alerts are sent using e-mail and/or SNMP traps when any monitored environmental condition exceeds a user-specified range
- Supplied with a MIB for integrating with various third party SNMP based Network Management systems such as Nagios and others
- Works with a wide range of sensors



Applications

Suitable for data centres, co-location centres, web hosting facilities, telecom racks or any unmanned area/site that needs to be monitored.

Front Panel LED Indicators

- Alarm
- Ready

Relay Outputs

- 4 relay outputs to control, switch on/off external devices such as fan, etc.
- Outputs can be used as a NO (Normally Open) or NC (Normally Closed).

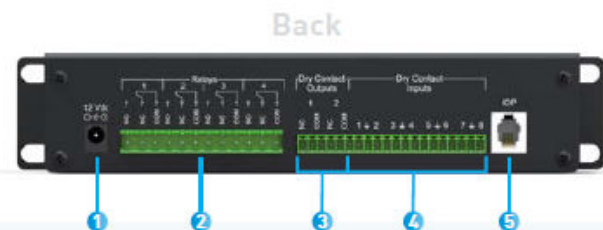

- 1 12 VDC Power input
- 2 4 x 10 A Relay Outputs
- 3 2 x Dry Contact Output
- 4 8 x Dry contact Input
- 5 Extension port for access control
[ACU should be connected for Access Control]
Further MCUs can be connected via this port.

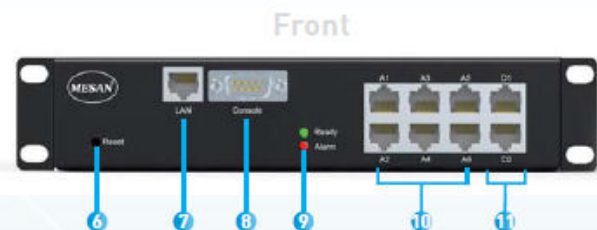

- 6 Reset Button
- 7 Ethernet port
- 8 Console
- 9 LED Indicators
- 10 6 x Analog Sensor inputs
- 11 2 x Digital Sensor inputs

Main Control Unit (MCU)

Web Interface

- ➔ Full monitoring and configuration via the web.
- ➔ Configuring sensor thresholds, set automatic operation and alarm rules.
- ➔ Automatically generated system logs
- ➔ Monitoring of current sensor values and alarm status
- ➔ Configure network settings (IP address, subnet mask, default gateway, DNS, etc.) and user administrative settings.



Technical Specifications

IP Monitoring	Web, SNMP
LAN	10 / 100 mb Ethernet
Operating system	Linux
Sensor Inputs	<ul style="list-style-type: none"> • 2x6P6C Digital bus(Humidity&Temperature, Smoke&Temperature) • Up to 20 digital sensors can be connected cascade • 6x6P6C Analog port (Vibration, WaterLeakage, Contact Sensor)
Relay Outputs:	4x on/off-10A
Dry Contact Inputs	8 x dry contact input
Dry Contact Outputs	2 x drycontact output (alarm outputs)
Power Supply	12Vdc
IOP port	for Access Control

Access Control Unit (ACU)



Stores a list of authorized users, controls electronic locks and monitors door status. Up to two **Als** can be connected to each **ACU**



This unit controls the **Als**, locks and the door status.
Stores a list of persons authorized to open the doors.

- Up to 100 users for keypad entries
- Up to 100 users for proximity cards

A 7-9V DC, 1.5A power supply is required.

Back

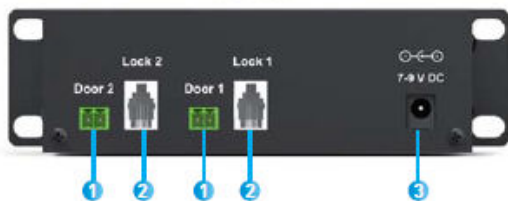

- 1 A sensor for detecting the state of the door (open / closed) can be connected.
- 2 Integrates with electronic locks supplied by Mesan.
- 3 7-9V DC power supply.

Front

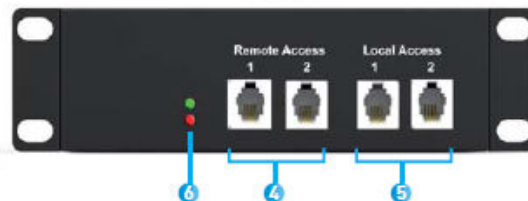

- 4 Management software
More ACUs can be linked together.
- 5 Proximity reader and keypad
- 6 Status LEDs

Management software

Configuration and testing utility for modules, ACU and Als

- ➔ Add and remove users
- ➔ Set the model and desired durations time (unlocked or door open)
- ➔ The period when access is permitted can be restricted.
- ➔ View and delete the logs
- ➔ No installation required

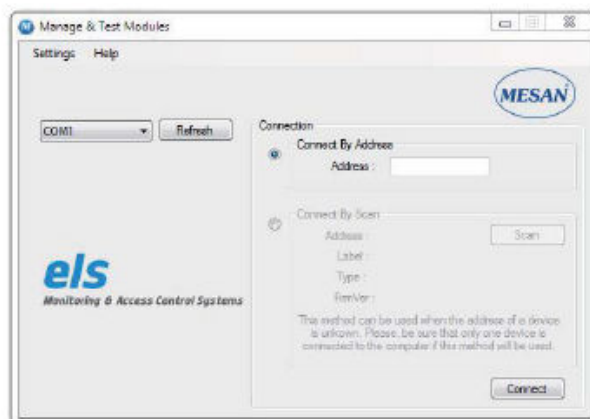

Access Interfaces (AIs)



Access interfaces are user interface devices that allow access by entering a code number or presenting a proximity card.

Beep tones and LEDs on the AI device inform the user about the acceptance or rejection of an operation.

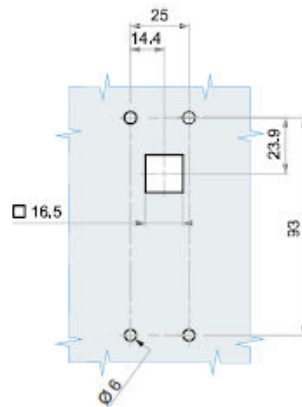

Cut Out

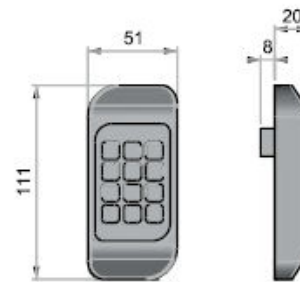

Custom Solutions

One of our existing solutions can be adapted to meet your requirements and provide the best customized solution for you. The many options for operating, access control and monitoring of applications – both indoor and outdoor – are shown on the following pages.

Access Control by RF Remote Control

This is a special application for access control of telecomms cabinets located outdoors. However, this existing solution can be adapted easily to other applications.

The modular design allows you to complement the features of your application by connecting a RF receiver to the MCU unit, which enables access control by a RF remote control device.



Automatic Electricity Metering

Should you require remote monitoring/metering of electricity consumption, electricity meters with an RS-485 interface can be used to provide you with:

- ➔ Remote monitoring of electricity meters in telecomms cabinets, base transceiver stations (BTS), etc.
- ➔ Monitor energy consumption in remote, unmanned or inaccessible areas
- ➔ Keep control over energy costs



Electricity Meter

The IEC 62056 metering standard is supported. There are meters certified compliant with IEC 62056 interface available from third party vendors in the market. Use of compliant electricity meters is mandatory.

Utility Controls Such As UPS, Rectifiers, Etc.

Using devices connected via RS-232, it is possible to monitor and remotely control these over the web. There is no need to change the existing utilities such as UPS, power rectifiers, etc. This facility offers the following benefits.

- ➔ Connect your current utilities over Ethernet
- ➔ Monitor UPSs and rectifiers over the web

IP Camera integration



To increase your security, you can integrate the MCU with your IP video surveillance system. This enables you to, for example, take a photograph when the cabinet door is opened and send this via the MCU.

Should you have a different requirement using an IP camera to the above example, please contact us

48V DC Power Option

48V DC is the voltage used most commonly in the telecommunications industry. Should you require a control unit that operates on 48V DC, we can supply this.

Sensors, Digital

	Humidity and Temperature	Sensor measures humidity and temperature indoors. Sensor contains an embedded temperature sensor.
Measured temperature range: (-)20 to (+) 60 °C		Measured humidity range : 10% to 90% PH Protocol : 1 wire
Connection : Sensor's 6P4C jack is connected to a digital input of the MCU or to an output of another digital sensor		
	Smoke and Temperature	For indoor applications such as rack cabinets, this sensor monitors the cabinet temperature and the occurrence of smoke. Sensor contains an embedded temperature sensor.
Measured temperature range: (-)20 to (+) 60 °C		Protocol : 1 wire
Connection : Sensor's 6P4C jack is connected to a digital input of the MCU or to an output of another digital sensor		

Sensors, Analog

	Water Leak	When water is detected by the metal probes, the sensor indicates the presence of moisture.
Connection : Sensor's 6P4C jack is connected to an analogue input of the MCU		
	Contact	Install this sensor on entrance doors, cabinet doors, windows, etc. to monitor whether these are open or closed. • Sensor uses a magnet and metal plate.
Connection : Sensor's 6P4C jack is connected to an analogue input of the MCU		
	Vibration	Sensor can be installed on walls, windows, etc., to monitor the vibration of the surface.
Connection : Sensor's 6P4C jack is connected to an analogue input of the MCU		
	Outdoor Temperature	Sensor can measure the temperature outside the premises and can also be used indoors.
Operating temperature range: (-)40 to (+) 100 °C		
Connection : Sensor's 6P4C jack is connected to an analogue input of the MCU		
	AC Voltage	Sensor can monitor the standard 220-230V mains power supply or any other capacity in the power supply system, for example in an outlet socket, in an extension lead or in a rack-mountable socket strip.
Connection : The device is inserted into the mains supply to be measured. The USB cable is inserted into the USB output socket on the sensor and the 6P4C connector is inserted into an analogue input socket on the MCU.		
	Motion (PIR)	Sensor can monitor movement over the range of the infrared beam.
Connection : Sensor's 6P4C jack is connected to an analogue input of the MCU		

System Modules And Accessories

Product	Product name	Product code	Product	Product name	Product code
	Main Control Unit	340.02.622		ACU Configuration Cable	340.02.630
	Access Control Unit	340.02.621		Humidity and Temperature Sensor	340.02.631
	Access Interface Keypad	340.02.623		Smoke and Temperature Sensor	340.02.632
	Access Interface Proximity	340.02.624		Water Leak Sensor	340.02.633
	7 - 9VDC Power Adaptor	340.02.626		Contact Sensor	340.02.634
	12 VDC Power Adaptor	340.02.625		Vibration Sensor	340.02.635
	USB-RS 485 Converter	340.02.627		Motion (PIR) Sensor	340.02.636
	IOPcom Connection Cable	340.02.628		Outdoor Temperature Sensor	340.02.637
	ACU- Lock Connection Cable	340.02.629		AC Voltage Sensor	340.02.638
	Proximity Card	340.02.640		Printed Proximity Card	340.02.639