

UNTHA

The reliable brand!



RS CLASS

30 | 40

4-shaft shredder for universal recycling applications



Reliability **for many years** to come

The reliable and highly robust RS30 and RS40 shredders have proven themselves over decades and were developed especially for a wide range of applications. The machines can be operated as stand-alone solutions or integrated within complex facilities, where they are popular due to their compact design.

They stand out for their high level of availability and process safety, their practical design and their unique productivity.

Suitable for

- » Automobile interior linings
- » Banknotes
- » Car bumpers
- » Cardboard
- » Cardboard tubes
- » Dashboards
- » Files
- » Foamboard
- » Foils
- » Green waste
- » Hard drives
- » Leather
- » Metal shavings
- » Organic waste
- » Packaging
- » Paper
- » Plastic barrels
- » Plastic bottles
- » Plastic containers
- » Production waste
- » Punching scrap
- » Rubber waste
- » Tetra Paks
- » Textiles
- » Transformer coils
- » Waste wood
- » and much more

The tried-and-tested UNTHA 4-shaft cutting system

4-shaft cutting system:

The tried-and-tested, patented 4-shaft cutting system was developed specifically for tough challenges. The cutting discs are resistant to non-shreddables, were designed for intense, continuous operation and are particularly economical due to their long service life.

Individually adaptable

The cutting system may be customised to suit the input material.

Slow-running cutting system

The cutting system is particularly resistant towards metal non-shreddables and stands out for its low dust and low noise production.

Compact design

The shredder is easy to integrate within existing plants.

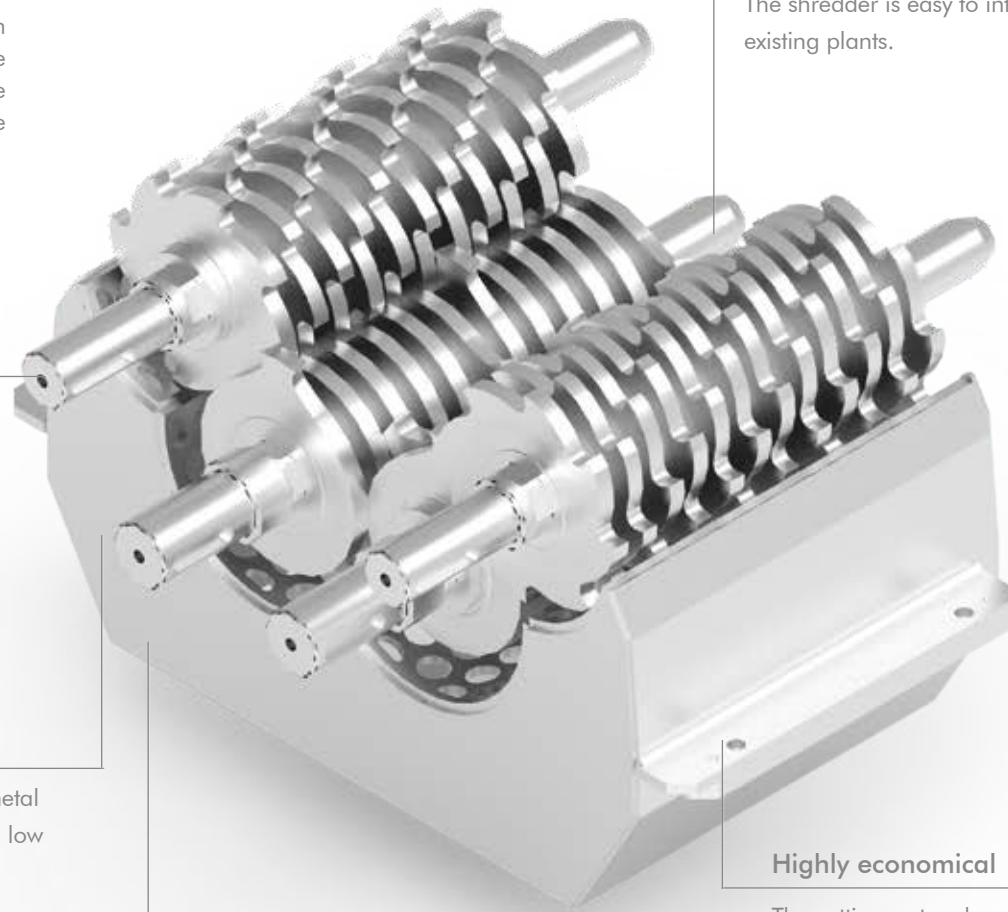

Low-wear screen

The screen ensures a defined fraction size and is easy to exchange thanks to the quick-change screen system.

Highly economical

The cutting system has a long service life.

Your benefits at a glance

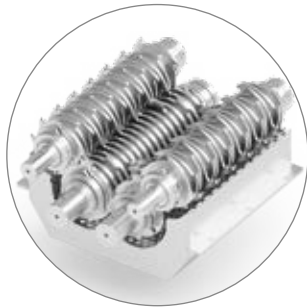

Economical cutting system

The material is pulled in by the cutting system, eliminating the need for a ram device. The four-shaft cutting system ensures a high torque, has a long service life and is highly resistant towards non-shreddables. The low speed keeps noise and dust production to a minimum. Thanks to the wide range of available cutting systems, the shredder may be adapted to suit the input material.

Long machine lifespan

Wear plates in the cutting chamber are easy to exchange, thereby prolonging the lifespan of the shredder. The maintenance-free mechanical seals prevent dust and dirt from entering gears and bearings. The torsion-resistant steel frame construction provides a stable, low-vibration base. The functional design protects the machine components from dirt.

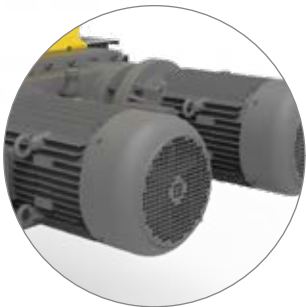

Reliable drive system

A staggered start-up of the two motors reduces current and power peaks. The streamlined structure (no hydraulic system; no couplings) makes this machine even more fault-resistant and keeps maintenance levels to a minimum.





Electronic protection systems

The automatic detection of non-shreddables with shut-off function and the automatic reverse function in case of engine overload, protect the drive unit against damage. The automatic shut-off function shuts down the machine while idling, further lowering energy costs.

Highly user- and maintenance-friendly

The integrated central lubrication system supplies all the important bearing points with a sufficient amount of lubricant. The gear oil level is monitored by an electronic oil level monitoring system.

Defined fraction size

Depending on the requirements, a range of screens ensures the production of pre-defined fractions. The large screen area achieves high throughput rates. An integrated quick-change screen system makes the screen easy and quick to exchange.



Sample image RS30/40

Options

Mechanical extras

- » Automated central lubrication system
- » Large selection of cutting discs

Electrical extras

- » Frequency converter for the continuous adjustment of speed to the input material and the reduction of power peaks when starting up the machine
- » Control system upgrade (light barrier, superordinate control system, BUS system, etc)
- » Integration of peripheral devices into the control system
- » Automatic start

Accessories

- » Hydraulic ram system
- » Customer-specific feed hoppers and undercarriages
- » Range of discharge feed systems (conveyor belts, screw conveyors, etc)
- » Suction hood with or without screw conveyor

Services

- » UNTHA Carefree Packages (Basic, Standard, Professional) ensure that machines are technically sound and ready for use at all times.



UNTHA test centre

UNTHA operates a state-of-the-art R&D centre where tests using customer-specific materials are simulated under real-life conditions. The customer, whose individual requirements we strive to meet in the best possible way, is always at the centre of what we do.

The test centre enables us to gather important experiences for real-life usage upfront, which means that with this knowledge we can offer our customers the best shredding solution for their needs.

Use this opportunity to schedule a trial run here with us!

RS30/40

4-shaft shredding system

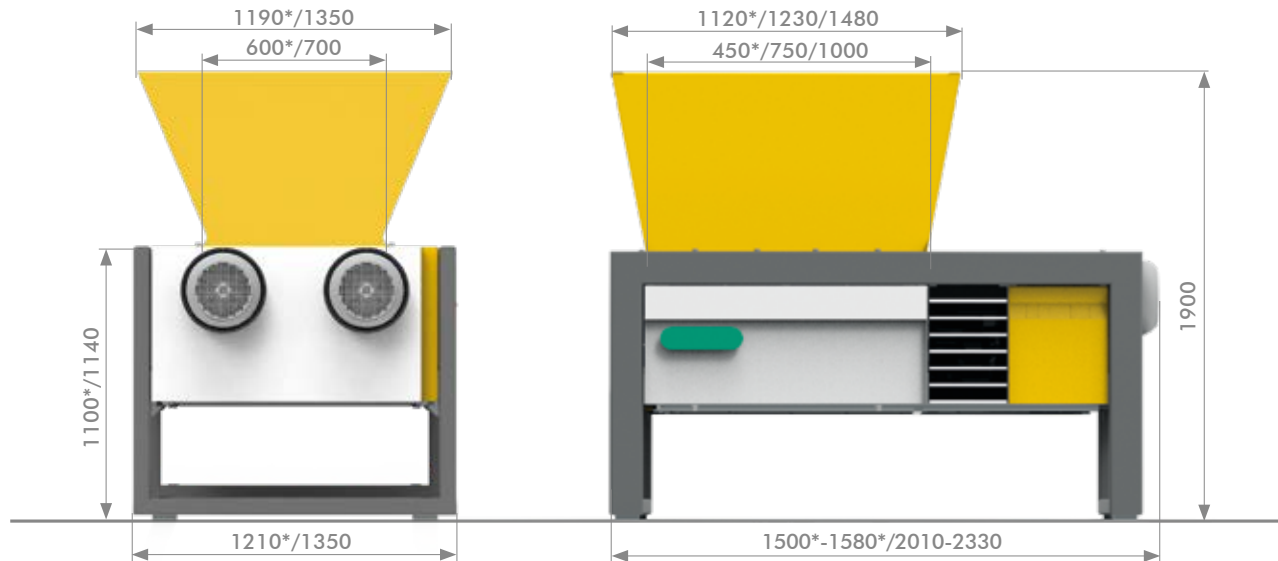

TECHNICAL DATA		RS30*	RS40
Rated capacity	kW	11/15/22	30/37/44
Cutter clearance	mm	450 x 600	750/1000 x 700
Number of shafts	pcs	4	4
Speed of the main shafts	rpm	23	24
Speed of the secondary shafts	rpm	34	32
Ø perforated screen	mm	15 - 40	15 - 40
Weight	kg	approx. 2.000	approx. 3.300/3.600

All dimensions in mm

UNTHA shredding technology GmbH

Kellau 141
5431 Kuchl | Österreich
Tel.: +43 6244 7016 0
Fax: +43 6244 7016 1
info@untha.com
www.untha.com

UNTHA Deutschland GmbH

Am Hammersteig 5a
97753 Karlstadt | Deutschland
Tel.: +49 9353 906869-0
Fax: +49 9353 906869-35
info@untha.de
www.untha.de

UNTHA UK Ltd.

Excel House, Becklands Close
Boroughbridge
YO51 9NR | United Kingdom
Tel.: +44 330 056 4455
sales@untha.co.uk
www.untha.co.uk

UNTHA America, Inc.

1 Lafayette Road, Building 4
Hampton, NH 03842 | USA
Tel.: +1 603 601 2304
Fax: +1 603 601 7573
info@untha-america.com
www.untha-america.com

UNTHA Polska Sp. z o.o.

Olecka 23/221
04-980 Warszawa | Polska
Tel.: +48 12 6421896
info@untha.pl
www.untha.pl

UNTHA Ibérica S.A.

Polígono de Sigüeiro - Parcela 58, Sigüeiro - Oroso / A
Coruña | España
Tel.: +34 981 69 10 54
Fax: +34 981 69 08 78
info@untha-iberica.com
www.untha.es

5 reasons to choose UNTHA



Customised, long-lasting shredding solutions



Premium quality products and services



All-encompassing expertise, from development to production, under one roof



Reliable customer service with the best technical know-how



More than 10,000 satisfied reference customers worldwide

We deliver what we promise

Since our founding in 1970, we've followed our promise of being "the reliable brand", which applies to every product and service that UNTHA delivers.

We work hard to consistently outperform our competitors, and provide customers with the confidence that – in choosing UNTHA – they have made the best decision for their business.

All revisions reserved. Subject to setting and printing errors.
All illustrations are representative and may deviate from the actual product.
© 04/22 UNTHA shredding technology